

TARGET J12



15 - 25 mm



4

INSTALLATION

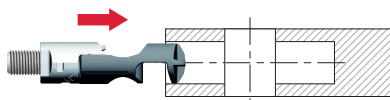

VERY IMPORTANT
Insert TARGET connecting with countersunk hole on top.

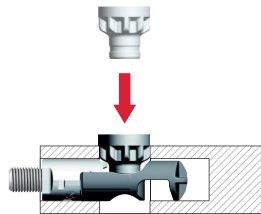
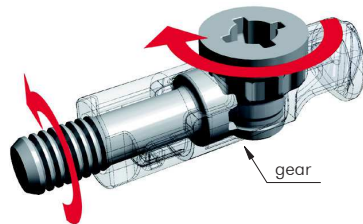
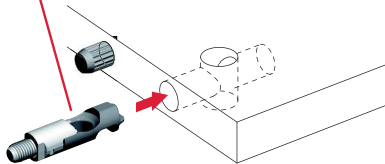

Place the pinion screw from above.

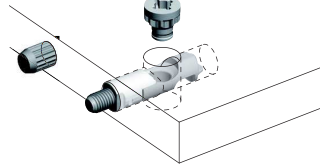

By turning the pinion screw, the threaded dowel makes a synchronized rotation.

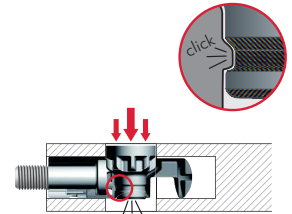

Press strongly with PZ2 cross screwdriver to slot the pinion screw in.

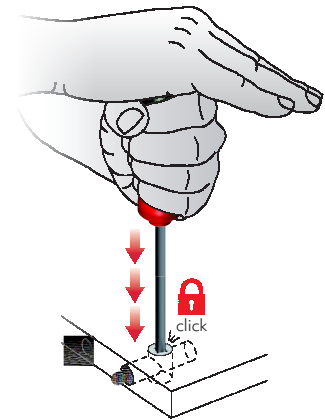

ASSEMBLING AND LEVELLER ADJUSTMENTS

VERY IMPORTANT
Cordless driver drill to be used ONLY with friction mode on.

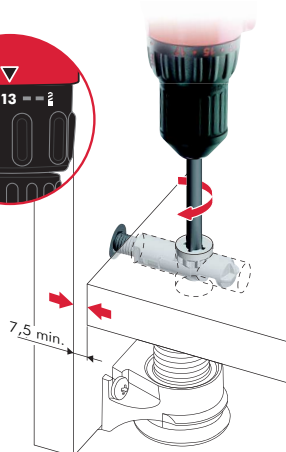
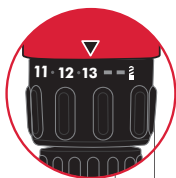

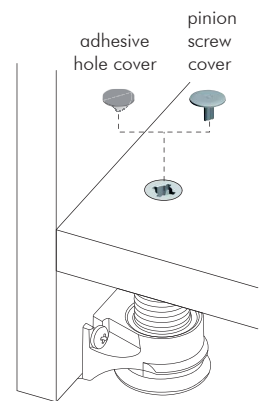
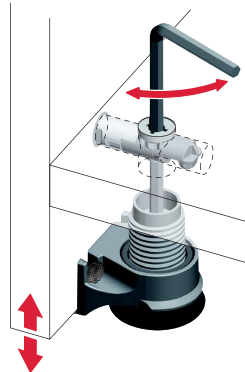

For details about adjustable levellers for TARGET J12 refer to the related sections.





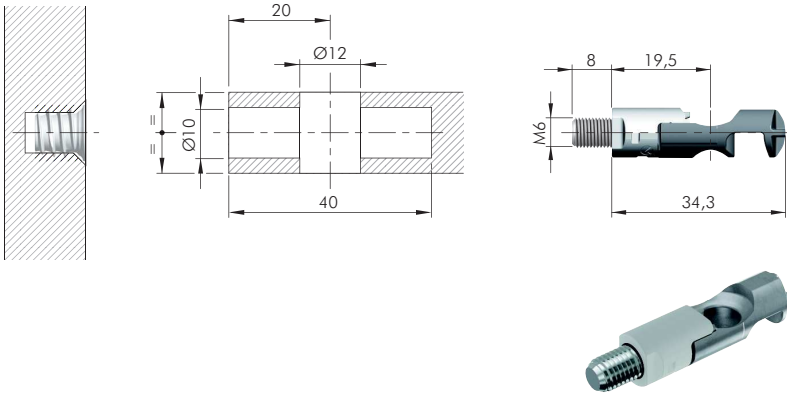

TARGET J12



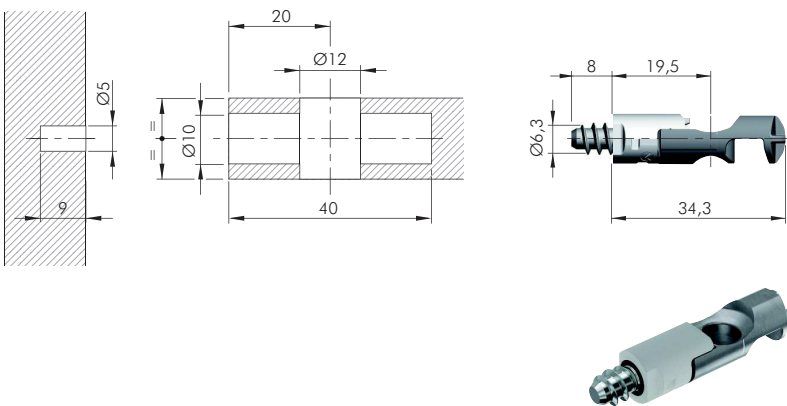

 = M6
 ZA ST EP  = 1000 pcs.



 
21807160ZN



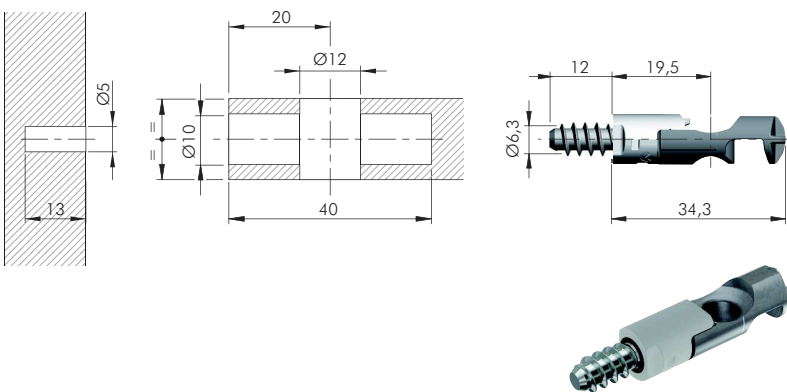

 = M6
 ZA ST EP  = 1000 pcs.

 
21808160ZN



 = M6
 ZA ST EP  = 1000 pcs.

 
21808240ZN

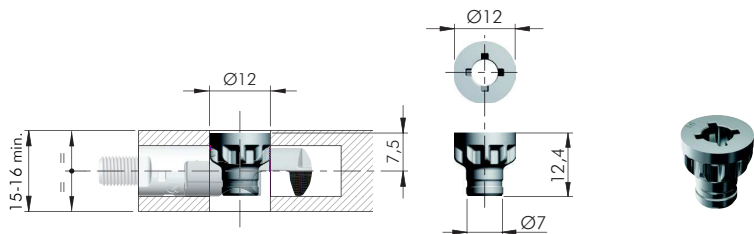

= PZ2 = Ø 12 mm
 = 15-16 mm min.
 = 2000 pcs.

21822160ZN

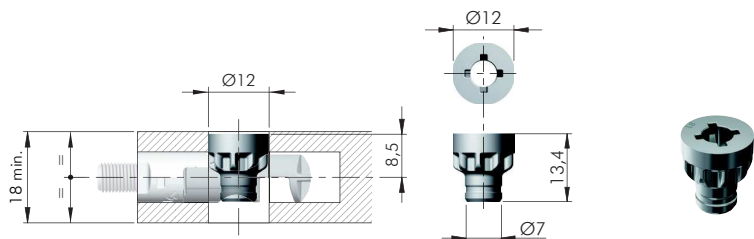

= PZ2 = Ø 12 mm
 = 18 mm min.
 = 2000 pcs.

21822180ZN

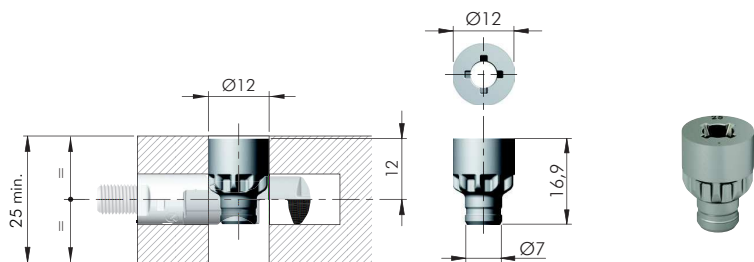

= PZ2 = Ø 12 mm
 = 25 mm min.
 = 2000 pcs.

21822250YA



All information about drilling jigs are available at the end of the section Target.