



Interzum Award:
Intelligent material & design 2017



15 - 25 mm



TARGET J10



INSTALLATION

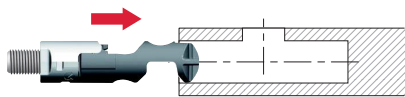

VERY IMPORTANT
Insert TARGET connecting with countersunk hole on top.

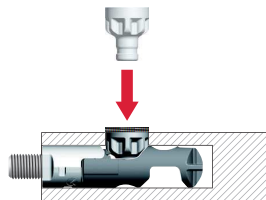
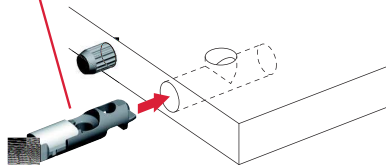

Place the pinion screw from above.

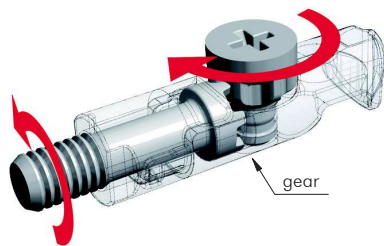
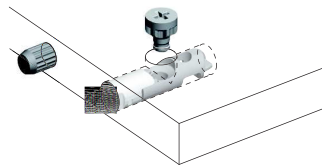

By turning the pinion screw, the threaded dowel makes a synchronized rotation.

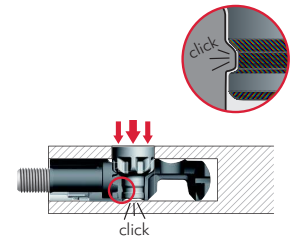

Press strongly with PZ2 cross screwdriver to slot the pinion screw in.

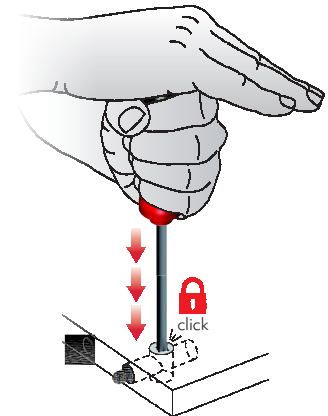

ASSEMBLING

⚠ VERY IMPORTANT

Cordless driver drill to be used **ONLY** with friction mode on.

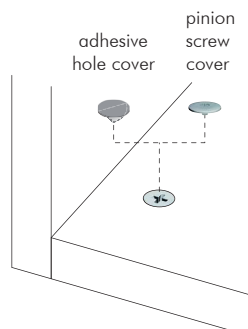
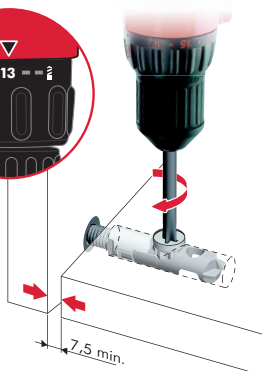
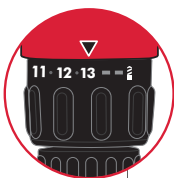

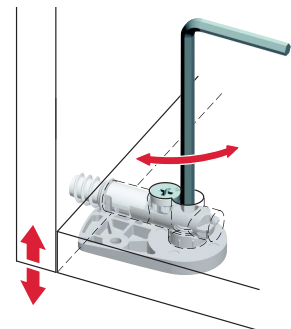

LEVELLER ADJUSTMENT



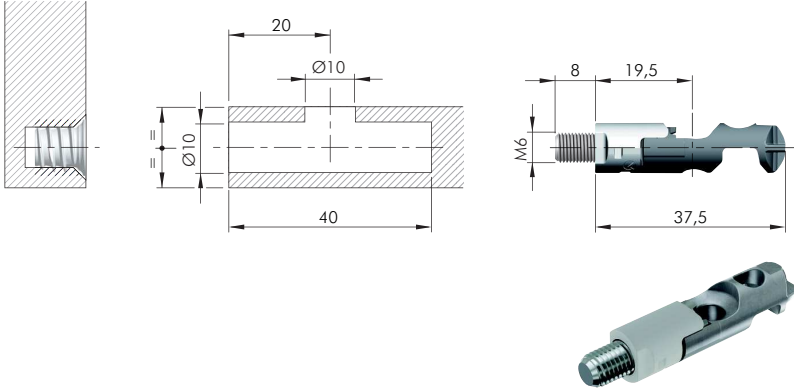

For details refer to the related section about adjustable feet available.

TARGET J10





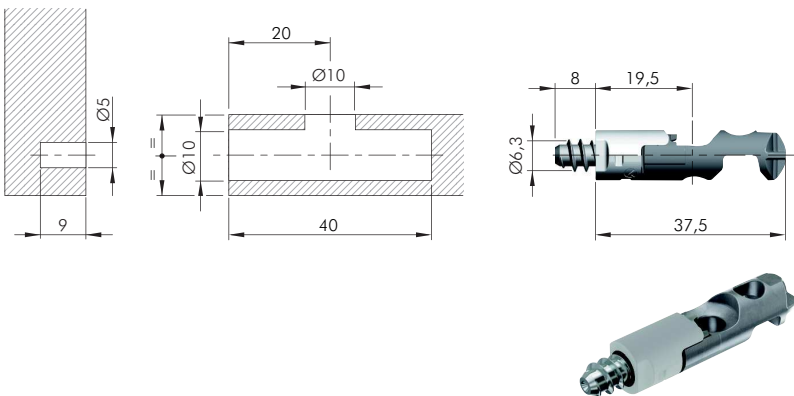

 = M6
 ZA ST EP  = 1000 pcs.

 
21802160ZN

4



 = M6
 ZA ST EP  = 1000 pcs.

 
21803160ZN

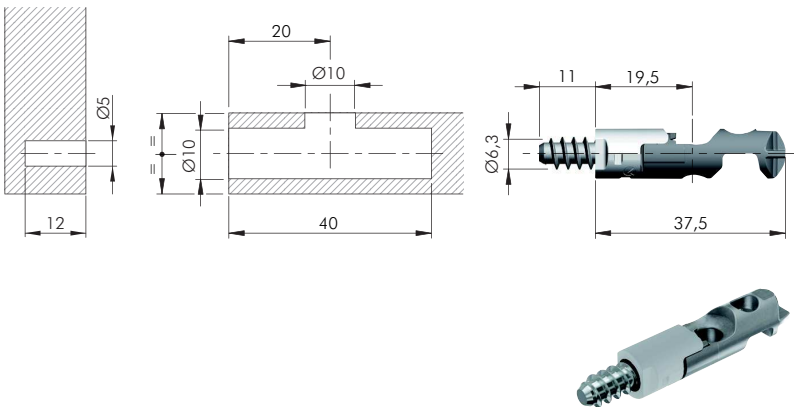

 = M6
 ZA ST EP  = 1000 pcs.

 
21803220ZN

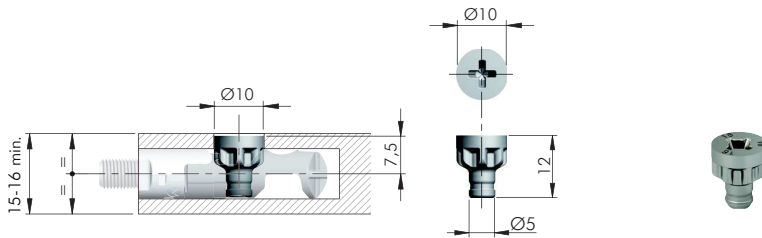

= PZ2 = Ø 10 mm
 = 15-16 mm min.
 = 2000 pcs.

21821160YA

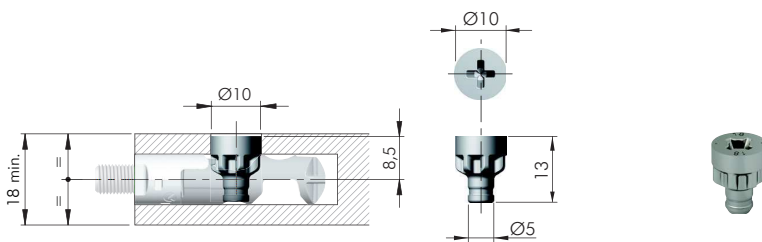

= PZ2 = Ø 10 mm
 = 18 mm min.
 = 2000 pcs.

21821180YA

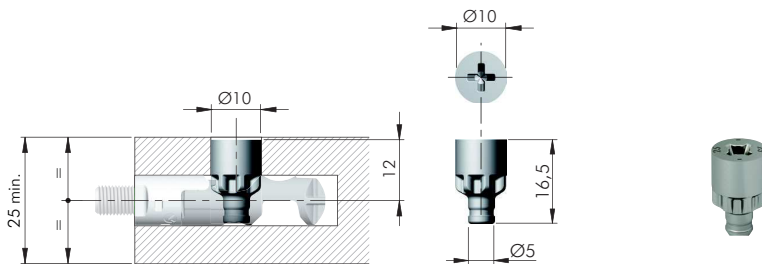

= PZ2 = Ø 10 mm
 = 25 mm min.
 = 2000 pcs.

21821250YA



All information about drilling jigs are available at the end of the section Target.