

THT

ACIER ZINGUÉ BLANC

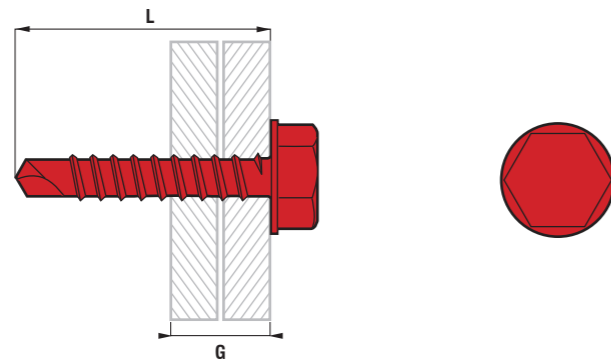

TÊTE HEXAGONALE
CRANTAGE SOUS TÊTE



Ø	L	G	Référence	capacité de perçage	cisaillement	traction	torsion	vitesse max.
Diamètre	mm	mm		mm	N	N	N	tr/min
3.5 5.5	10	4	THT5-35010					
	13	7	THT5-35013					
	16	10	THT5-35016	2.0	2 930	5 000	2 800	2 500
	19	13	THT5-35019					
3.9 5.5	25	19	THT5-35025					
	13	7	THT5-39013					
	16	10	THT5-39016	2.5	3 650	6 000	3 800	2 500
4.2 7	19	13	THT5-39019					
	13	6	THT7-42013					
	16	9	THT7-42016					
	19	12	THT7-42019					
4.2 7	22	15	THT7-42022	3.0	4 360	7 000	4 800	2 500
	25	18	THT7-42025					
	32	25	THT7-42032					

THT

Ø	L	G	Référence	capacité de perçage	cisaillement	traction	torsion	vitesse max.
Diamètre	mm	mm		mm	N	N	N	tr/min
4.8 8	13	4	THT8-48013					
	16	7	THT8-48016					
	19	10	THT8-48019					
	22	13	THT8-48022					
	25	16	THT8-48025	4.0	6 280	10 000	7 000	2 000
	32	23	THT8-48032					
	38	29	THT8-48038					
	45	36	THT8-48045					
5.5 8	50	41	THT8-48050					
	19	9	THT8-55019					
	22	12	THT8-55022					
	25	15	THT8-55025					
	32	22	THT8-55032					
	38	28	THT8-55038	5.0	8 360	12 500	10 500	1 750
	45	35	THT8-55045					
6.3 10	50	40	THT8-55050					
	63	53	THT8-55063					
	75	65	THT8-55075					
	19	8	THT10-63019					
	22	11	THT10-63022					
	25	14	THT10-63025					
	32	21	THT10-63032					
	38	27	THT10-63038					
	45	34	THT10-63045	6.0	12 770	17 000	17 000	1 500
	50	39	THT10-63050					
6.3 10	63	52	THT10-63063					
	75	64	THT10-63075					
	100	89	THT10-63100					
	125	114	THT10-63125					
	150	139	THT10-63150					

15

15