

PUSH CONTROL EVOLUTION

		VERSIONS			
		Modèle livré	Recoupable de 838 à 635	Recoupable de 1141 à 820	
		1 Point Blocage NFS61-937 DAS fiche XIV	<input type="checkbox"/>	900101	910101
		2 points 1 Haut et 1 bas Blocage NFS61-937 DAS fiche XIV	<input type="checkbox"/>	930101	940101
		1 Point Blocage + Détection NFS61-937 DAS fiche XIV	<input type="checkbox"/>	900111	910111
		2 Points 1 Haut et 1 bas Blocage + Détection NFS61-937 DAS fiche XIV	<input type="checkbox"/>	930111	940111
TENSION COMPATIBLE AVEC MODELE LIVRE		1 Point Blocage + Dogging NFS61-937 DAS fiche XIV	<input type="checkbox"/>	900 411	910 411
24 V	48 V	2 points 1 Haut et 1 bas Blocage + Dogging NFS61-937 DAS fiche XIV	<input type="checkbox"/>	930411	940411
<input type="checkbox"/>	<input type="checkbox"/>	1 Point Dogging + Détection	<input type="checkbox"/>	900 310	910 310
		2 points 1 Haut et 1 bas Dogging + Détections	<input type="checkbox"/>	930310	940310

Préambule

MISE EN PLACE DU CONTACT MAGNETIQUE DE POSITION DE PORTE - (Sauf version Blocage seul)

- Repérer et percer l'emplacement du détecteur, de l'aimant et le passage des fils selon le plan.
- En présence d'une huisserie métallique, ajouter les Isolants pour l'aimant et le détecteur.
- Raccorder les deux fils du détecteur sur le circuit de tête selon le schéma.
- Mettre le capot de tête avec les 2 vis de fixation.

IMPORTANT

- L'intervalle A entre l'aimant et le détecteur ne doit pas excéder 10mm.
- Ne jamais taper sur le détecteur pour le loger dans le perçage, celui-ci est "fragile".
- En conséquence, les perçages pour l'aimant et le détecteur doivent être suffisamment précis ($\varnothing 7,6$ mm) pour permettre leur insertion correcte ; si besoin, les fixer avec une colle adaptée à l'huisserie.

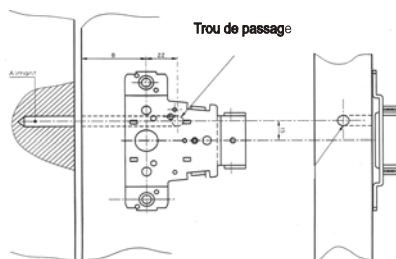
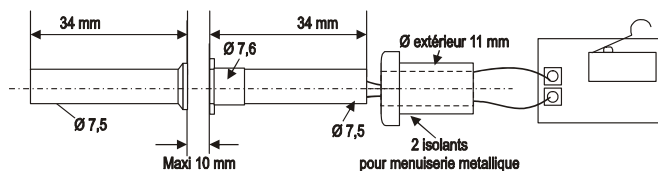

Fig 1

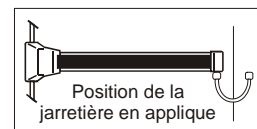

Fig 2

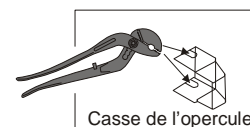
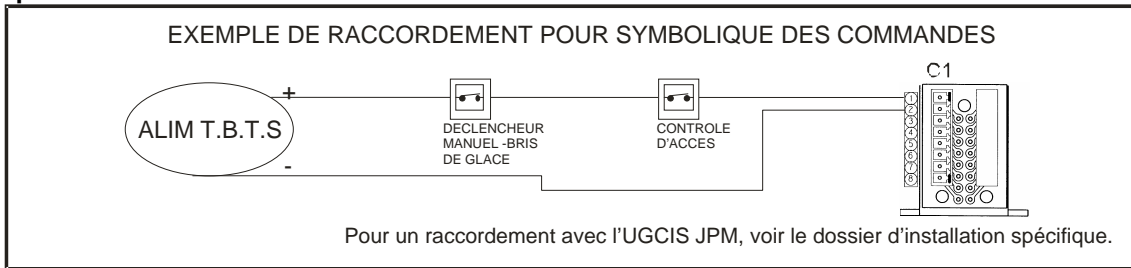

Fig 3

ASSA ABLOY Côte Picarde S.A.S. – Siège social - Rue Alexandre Fichet - 80460 OUST-MAREST
 Tél : 33 (0) 3 22 61 27 00 – Fax : 33 (0) 3 22 61 27 27 - Adresse postale : CS 60024 - 80532 FRIVILLE CEDEX
 Capital : 8 862 560 € - R.C.S Amiens 408024529 - Code APE 2572 Z - TVA : FR 44408024529 - www.abloy.fr

Principe de base



Généralités

CONSUMMATION.

Fonctions	24Vcc	48Vcc
Consommation BLOCAGE	157mA	106mA
Conso. en pointe DOGGING	2A	1A
Conso. normale DOGGING	550mA	320mA

POUVOIR DE COUPURE :

ATTENTE + SÉCURITÉ 1A / 30Vcc
 PORTE 300mA /30Vcc PÊNE 2A / 30Vcc
 APPUI DE BARRE 1A / 30Vcc
 Température de fonctionnement 0°C à +70°C

RECOMMANDATIONS

Alimentations : T.B.T.S. STABILISEE+REGULEE -15%<Un<+20%. Une sauvegarde batterie est conseillée pour les 2 types de PUSH CONTROL
Câbles : Utiliser obligatoirement le câble fourni entre le bornier de la push et le boîtier électronique de relaying.
Conditions : Le produit ne doit pas être exposé aux intempéries (IP42).
Règles : Respecter les règles d'installations prescrites par la norme NFS61.932. Toutes les bornes doivent être soumise aux caractéristiques des alimentations T.B.T.S. suivant la norme NFC15.100

Version Blocage		Version Blocage et Détection																																																							
	<table border="1"> <thead> <tr> <th>n°</th> <th>Connecteur C1</th> </tr> </thead> <tbody> <tr><td>1</td><td>Alim. + BLOCAGE</td></tr> <tr><td>2</td><td>Alim. - BLOCAGE</td></tr> <tr><td>3</td><td></td></tr> <tr><td>4</td><td></td></tr> <tr><td>5</td><td></td></tr> <tr><td>6</td><td></td></tr> <tr><td>7</td><td></td></tr> <tr><td>8</td><td></td></tr> </tbody> </table>	n°	Connecteur C1	1	Alim. + BLOCAGE	2	Alim. - BLOCAGE	3		4		5		6		7		8			<table border="1"> <thead> <tr> <th>n°</th> <th>Connecteur C1</th> <th>n°</th> <th>Connecteur C2</th> </tr> </thead> <tbody> <tr><td>1</td><td>Alim. + BLOCAGE</td><td>16</td><td>Etat ATTENTE Commun.</td></tr> <tr><td>2</td><td>Alim. - BLOCAGE</td><td>15</td><td>Etat ATTENTE NO.</td></tr> <tr><td>3</td><td>Appui de barre Commun.</td><td>14</td><td>Etat ATTENTE NF.</td></tr> <tr><td>4</td><td>Appui de barre NO.</td><td>13</td><td>Etat SECURITE Commun.</td></tr> <tr><td>5</td><td>Appui de barre NF.</td><td>12</td><td>Etat SECURITE NO.</td></tr> <tr><td>6</td><td></td><td>11</td><td>Etat SECURITE NF.</td></tr> <tr><td>7</td><td>Etat pêne Sorti/NF</td><td>10</td><td>Etat porte</td></tr> <tr><td>8</td><td>Etat pêne Sorti/NF</td><td>9</td><td>Etat porte</td></tr> </tbody> </table>	n°	Connecteur C1	n°	Connecteur C2	1	Alim. + BLOCAGE	16	Etat ATTENTE Commun.	2	Alim. - BLOCAGE	15	Etat ATTENTE NO.	3	Appui de barre Commun.	14	Etat ATTENTE NF.	4	Appui de barre NO.	13	Etat SECURITE Commun.	5	Appui de barre NF.	12	Etat SECURITE NO.	6		11	Etat SECURITE NF.	7	Etat pêne Sorti/NF	10	Etat porte	8	Etat pêne Sorti/NF	9	Etat porte
n°	Connecteur C1																																																								
1	Alim. + BLOCAGE																																																								
2	Alim. - BLOCAGE																																																								
3																																																									
4																																																									
5																																																									
6																																																									
7																																																									
8																																																									
n°	Connecteur C1	n°	Connecteur C2																																																						
1	Alim. + BLOCAGE	16	Etat ATTENTE Commun.																																																						
2	Alim. - BLOCAGE	15	Etat ATTENTE NO.																																																						
3	Appui de barre Commun.	14	Etat ATTENTE NF.																																																						
4	Appui de barre NO.	13	Etat SECURITE Commun.																																																						
5	Appui de barre NF.	12	Etat SECURITE NO.																																																						
6		11	Etat SECURITE NF.																																																						
7	Etat pêne Sorti/NF	10	Etat porte																																																						
8	Etat pêne Sorti/NF	9	Etat porte																																																						

Version Blocage Dogging Détection	Version Dogging Détection
<p>Push Control est une Fermeture anti-panique motorisée contrôlée électriquement.</p> <ul style="list-style-type: none"> ■ Sous tension elle permet de verrouiller la barre de manoeuvre pour la sortie, de déverrouiller et rétracter les pènes par motorisation en entrée. ■ Hors tension, elle fonctionne comme une fermeture anti-panique standard, une simple poussée sur la barre de manoeuvre, exercée perpendiculairement à la porte, permet l'ouverture automatique. ■ Destination Portes isolées avec boîtier bris de glace (et détection incendie) + report d'informations GTC / contrôle d'accès. Portes issues de secours contrôlées par dispositif de centralisation CMSI à fonction de Gestion Centralisée d'Issue de Secours UGCIS (gestion de temporisation 8sec et 3min), ■ Normes et réglementation. Les PUSH CONTROL BLOCAGE DOGGING sont conformes à la norme NFS61-937 (D.A.S. : Dispositif Actionné de Sécurité, annexe A, fiche XIV) Ces fermetures sont Conformes au règlement de sécurité contre l'incendie dans les lieux recevant du public (article CO46). L'installation doit être réalisée suivant la norme NFS61-932, après avis de la commission de sécurité et selon les indications de l'article CO46 Nota : Les PUSH CONTROL versions BLOCAGE DOGGING DETECTIONS ne sont pas aptes à équiper les portes coupe-feu. Toutefois si le bloc porte possède un PV d'essais où la présence du pêne de verrouillage mécanique n'est pas obligatoire, le produit peut être installé 	<p>Push Control est une Fermeture anti-panique motorisée contrôlée électriquement.</p> <ul style="list-style-type: none"> ■ Sous tension elle permet, de déverrouiller et rétracter les pènes par motorisation. En sortie, elle fonctionne comme une fermeture anti-panique standard, une simple poussée sur la barre de manoeuvre, permet l'ouverture automatique. ■ Destination Portes issues de secours d'Etablissements Recevant du Public soumises à un contrôle d'accès (hôpitaux, maisons de retraite, musée, établissements d'enseignement, super et hypermarchés...). ■ Normes et réglementation. Les PUSH CONTROL DOGGING+DETECTIONS sont conformes au règlement de sécurité contre l'incendie dans les lieux recevant du public (article CO45). L'installation doit être réalisée suivant les normes en vigueur, après avis de la commission de sécurité et selon les indications de l'article CO45 et CO46. Nota : Les PUSH CONTROL versions DOGGING DETECTION ne sont pas aptes à équiper les portes coupe-feu. Toute fois si le bloc-porte possède un PV d'essais où la présence du pêne de verrouillage mécanique n'est pas obligatoire, le produit peut être installé.

Schéma de câblage : voir notice NO1-135 Le circuit extérieur de gestion livré doit être impérativement raccordé.

Les produits PUSH CONTROL sont conformes aux normes et réglementations électriques de compatibilité électromagnétique suivant la directive Européenne 89/336/CEE

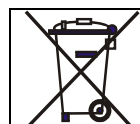

Certains matériels, comme les composants électriques demandent des techniques spéciales de recyclage.

PRODUITS CONCERNES

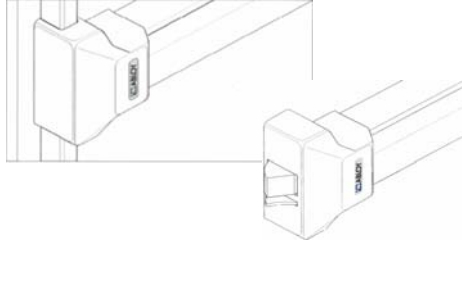
		VERSIONS		Delivred version	Recoupable de 838 à 635	Recoupable de 1141 à 820
		COMPATIBLE TENSION WITH DELIVRED VERSION				
24 V	48 V	1 Point BloKking NFS61-937 DAS fiche XIV	<input type="checkbox"/>	900101	910101	
		2 Point BloKking NFS61-937 DAS fiche XIV	<input type="checkbox"/>	930101	940101	
		1 Point BloKking + Détection NFS61-937 DAS fiche XIV	<input type="checkbox"/>	900111	910111	
		2 Points BloKking + Détection NFS61-937 DAS fiche XIV	<input type="checkbox"/>	930111	940111	
		1 Point BloKking + Monitoring + Détections NFS61-937 DAS fiche XIV	<input type="checkbox"/>	900 411	910 411	
		2 Point BloKking + Monitoring + Détections NFS61-937 DAS fiche XIV	<input type="checkbox"/>	930411	940411	
		1 Point Monitoring + Détection	<input type="checkbox"/>	900 310	910 310	
		2 Point Monitoring + Détections	<input type="checkbox"/>	930310	940310	

Préambule

INSTALLATION OF THE MAGNETIC CONTACT FOR DOOR POSITION

- Mark and drill the detector hole, the magnet and wires passage position as indicated below.
- In case of a metallic frame, add the insulator (Ø11 mm) for the magnet and the detector.
- Plug the two wires of the detector on the head circuit as indicated.

Install the main case cover with the 2 fixing screws

IMPORTANT

- The space between the magnet and the detector must not exceed 10mm
- Never bang on the detector to insert it in the drilling because it is "fragile".

Then the drillings for the magnet and the detector must be precise enough (Ø 7,6 mm) to allow correct insulation, if it is necessary, fix them with a glue adapted to the frame

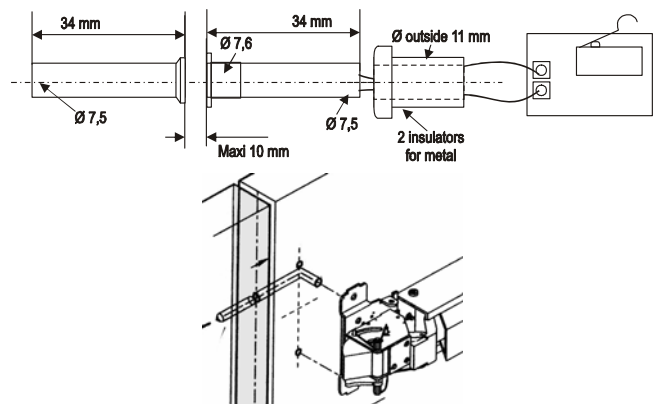
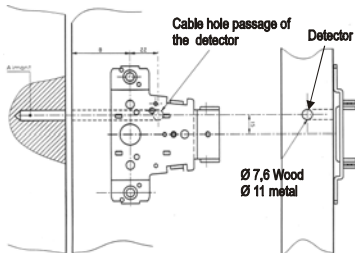

INSTALLATION OF THE CONNECTORS

- After cutting the bar at the right leaf dimension, check that no metallic particles are remaining.
- Pull out the nylon collar until approaching the connectors support at the end of the bar. (Drawing 1)
- Remove the single or the two connectors from support :
- Single connector = locking version

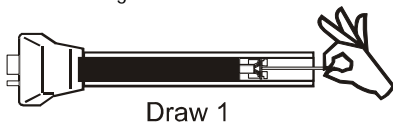

- end bracket according to of the hand of the product (Drawing 3).
- Fix the end bracket thanks to the 2 screws.

WIRING.

- Pass the cable through the rim (Drawing 2) or the flushed (mortise) lead cover. Abloy recommends the flushed (mortise) solution in order to avoid vandalism.
- Connect the coloured passage (16) according to the selected system version and remote accessories (see table on Page 2).
- Settle connectors while pressing on the active bar in order to immobilize the connectors support...
- Cut the excess of plastic collar.
- In case of a rim lead cover, break the precut part of the

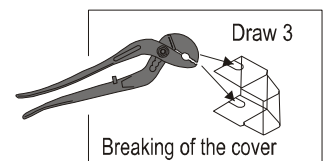
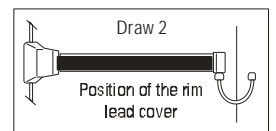

Basic principle

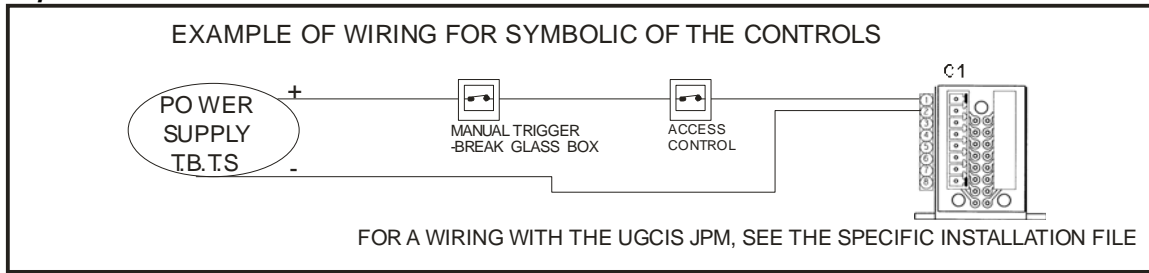

Majorities

CONSUMMATION.

Fonctions	24Vcc	48Vcc
Consumption BLOCKING	57mA	106mA
High consump. DOGGING	2A	1A
Normal consump. DOGGING	550mA	320mA

POUVOIR DE COUPURE :

APPUI DE BARRE 1A / 30Vdc

WAITING + SECURITY 1A / 30Vdc

DOOR 300mA / 30Vdc BOLT 2A / 30Vdc

Functioning temperature : 0°C to +70°C

ADVICE

Power supply: T.B.T.S STABILIZED + REGULATED -15%<Un<+20%. A safeguard battery is recommended for both types of PUSH CONTROL SYSTEMS

Wires : Use only the wire delivered between the push connector and the engine control circuit.

Conditions : The product must not be exposed to the bad weather (Ip42)

Rules : Respect the installation instructions given in the NFS61.932 standard. All the terminals must be subjected to the characteristics of the T.B.T.S power supply in function of the NFC15.100 standard.

Blocking Version	Blocking and detection Version																																																						
<table border="1"> <thead> <tr> <th>n°</th> <th>Connector C1</th> </tr> </thead> <tbody> <tr><td>1</td><td>Power supply + LOCKING</td></tr> <tr><td>2</td><td>Power supply - LOCKING</td></tr> <tr><td>3</td><td></td></tr> <tr><td>4</td><td></td></tr> <tr><td>5</td><td></td></tr> <tr><td>6</td><td></td></tr> <tr><td>7</td><td></td></tr> <tr><td>8</td><td></td></tr> </tbody> </table>	n°	Connector C1	1	Power supply + LOCKING	2	Power supply - LOCKING	3		4		5		6		7		8		<table border="1"> <thead> <tr> <th>n°</th> <th>Connector C1</th> <th>n°</th> <th>Connector C2</th> </tr> </thead> <tbody> <tr><td>1</td><td>Power supply + LOCKING</td><td>16</td><td>WAITING common status wiring (Blocked)</td></tr> <tr><td>2</td><td>Power supply - LOCKING</td><td>15</td><td>WAITING NO status</td></tr> <tr><td>3</td><td>Wire bar press</td><td>14</td><td>WAITING NF status</td></tr> <tr><td>4</td><td>NO bar press</td><td>13</td><td>SECURITY common status wiring (unblocked)</td></tr> <tr><td>5</td><td>NF bar press</td><td>12</td><td>SECURITY NO status</td></tr> <tr><td>6</td><td></td><td>11</td><td>SECURITY NF status</td></tr> <tr><td>7</td><td>Bolt out status / NF</td><td>10</td><td>Door status</td></tr> <tr><td>8</td><td>Bolt out status / NF</td><td>9</td><td>Door status</td></tr> </tbody> </table>	n°	Connector C1	n°	Connector C2	1	Power supply + LOCKING	16	WAITING common status wiring (Blocked)	2	Power supply - LOCKING	15	WAITING NO status	3	Wire bar press	14	WAITING NF status	4	NO bar press	13	SECURITY common status wiring (unblocked)	5	NF bar press	12	SECURITY NO status	6		11	SECURITY NF status	7	Bolt out status / NF	10	Door status	8	Bolt out status / NF	9	Door status
n°	Connector C1																																																						
1	Power supply + LOCKING																																																						
2	Power supply - LOCKING																																																						
3																																																							
4																																																							
5																																																							
6																																																							
7																																																							
8																																																							
n°	Connector C1	n°	Connector C2																																																				
1	Power supply + LOCKING	16	WAITING common status wiring (Blocked)																																																				
2	Power supply - LOCKING	15	WAITING NO status																																																				
3	Wire bar press	14	WAITING NF status																																																				
4	NO bar press	13	SECURITY common status wiring (unblocked)																																																				
5	NF bar press	12	SECURITY NO status																																																				
6		11	SECURITY NF status																																																				
7	Bolt out status / NF	10	Door status																																																				
8	Bolt out status / NF	9	Door status																																																				

BLOCKING + MONITORING version	MONITORING + DETECTIONS version
<p>PUSH CONTROL is a mechanised panic exit device electrically controlled. Electromagnetic locking of the push bar at positive security + mechanised retraction of the bolts (maintain of the swing door) + electrical informations given on the product and the door = screen the entries and exits and know the state of the system</p> <p>Undervoltage it enables, to lock the push bar for the exit, to unlock and retract the bolts by mechanisation</p> <p>Out of order: it works as a standard panic exit device, a simple pressure on the push bar perpendicular to the door, permits the automatic opening, a slight pressure on the touch bar permits a maximal free passage and limiting damages</p> <p>Destination : Emergency exit doors of establishments opened to the public electrically locked (hospitals, old people's home, museums, educational establishments, super and hypermarkets...)</p> <p>Emergency exit doors in banking establishments and doors of administration and industrial sites. Isolated door with a glass break box (and fire detection) + informations report GTC / access control</p> <p>Emergency exits doors controlled by a centralised device CMSI with the function of Centralised Control of Emergency Exit UGCIS (temporising control of 8sec and 3 min).</p> <p>Standards and reglementation. The PUSH CONTROL BLOCKING DOGGING are in accordance with the NFS61-937 standard (D.A.S. : Activated Safety Device, annexe A, slip XIV) Ces fermetures sont These closings are then in accordance with the security regulation against fire in the establishments opened to the public (CO46 article).</p>	<p>PUSH CONTROL is a mechanised panic exit device electrically controlled.</p> <ul style="list-style-type: none"> ■ Undervoltage it enables, to lock the push bar for the exit, to unlock and retract the bolts by mechanisation ■ Out of order, it works as a standard panic exit device, a simple pressure on the push bar perpendicular to the door, permits the automatic opening, a slight pressure on the touch bar permits a maximal free passage and limiting damages ■ Destination Emergency exit doors of establishments opened to the public electrically locked (hospitals, old people's home, museums, educational establishments, super and hypermarkets...) Emergency exit doors in banking establishments and doors of administration and industrial sites. Parking or high building stairs exit door subjected to a access control ■ Normes et reglementation. The PUSH CONTROL DOGGING + DETECTIONS are in accordance with the security regulation against fire in the establishments opened to the public (CO45 article). The installation must be realised in accordance with the standards in effect, after notification of the security commission and in accordance with the indications of the CO45 and CO46 article. Note: The PUSH CONTROL DOGGING DETECTIONS version are not suited to equip fire-rated doors. However if the unit door has a PV of tests where the presence of the mechanical bolt of locking is not obligatory, the product can be installed.

Nota : The PUSH CONTROL BLOCKING DOGGING DETECTIONS version are not suited to equip fire-rated doors. However if the unit door has a PV of tests where the presence of the mechanical bolt of locking is not obligatory, the product can be installed.

WIRING INSTRUCTIONS see instruction : N01-135 The outside DOGGING engine control circuit delivered must be obligatory linked

CE The PUSH CONTROL products are certified in accordance with the standard and electrical regulations of the electromagnetic compatibility according to the European directive 89/336/CEE

Certain materials(equipments), as the electric constituents(components) ask for special techniques of recycling.