

# TM2 X R MINI

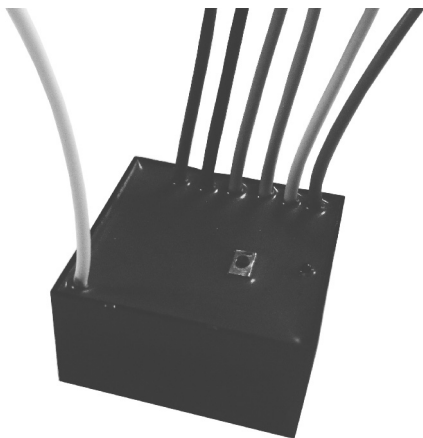

**FAAC**

# SOMMARIO

ISTRUZIONI PER LA SICUREZZA .....	3
COLLEGAMENTI ELETTRICI .....	3
LEGENDA DEI SIMBOLI .....	4
CARATTERISTICHE TECNICHE .....	4
SPIEGAZIONE DELLE SEQUENZE DI COMANDO .....	5
FUNZIONE APERTURA/CHIUSURA PROGRAMMAZIONE TELECOMANDO TM2 X T .....	6
MEMORIZZAZIONE PRIMO TELECOMANDO .....	7
IMPOSTAZIONE DEL SENSO DI ROTAZIONE DEL MOTORE .....	7
MEMORIZZAZIONE DI ALTRI TELECOMANDI .....	8
CANCELLAZIONE SINGOLO TELECOMANDO .....	9
CANCELLAZIONE TOTALE DELLA MEMORIA TELECOMANDI .....	9
AZIONAMENTO DA TELECOMANDO .....	10
COMANDO FILARE OPZIONALE .....	11
FUNZIONAMENTO CON SENSORE SOLE/VENTO .....	13
SENSORE TM2 X W .....	14
ANEMOMETRI .....	15
MEMORIZZAZIONE TEMPORANEA TELECOMANDO .....	17
DICHIARAZIONE DI CONFORMITÀ EU .....	18

# ISTRUZIONI PER LA SICUREZZA

- L'installazione deve essere eseguita da personale tecnico nel pieno rispetto delle norme di sicurezza, soprattutto per quanto riguarda i collegamenti elettrici.
- A monte della centralina prevedere un interruttore bipolare automatico per la protezione dai corto circuiti, con distanza di apertura dei contatti di almeno 3 mm.
- Se il filo bianco non è utilizzato deve essere sempre isolato. È pericoloso toccare il filo bianco quando la centralina è alimentata.

## COLLEGAMENTI ELETTRICI

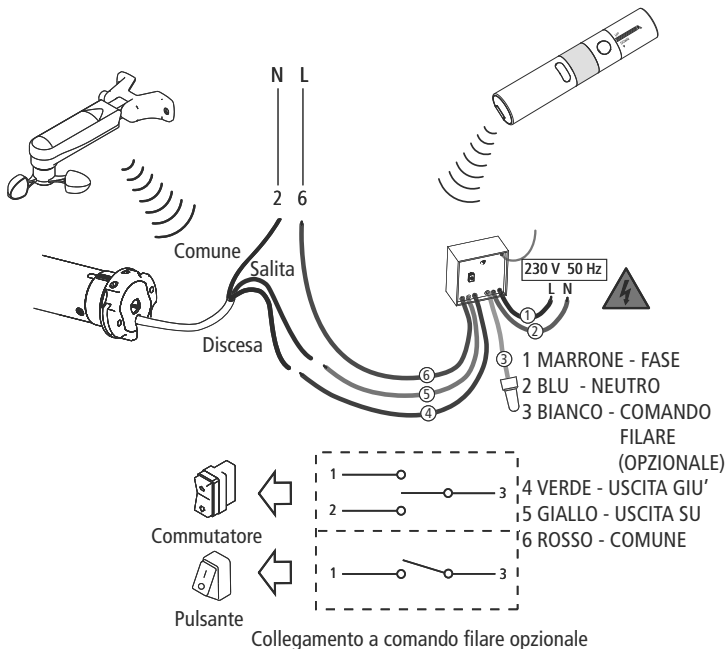

# LEGENDA DEI SIMBOLI

IT

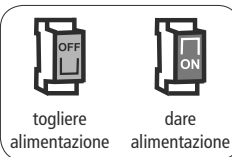
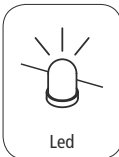
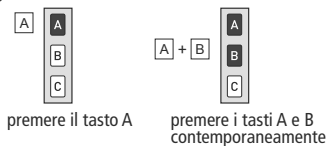
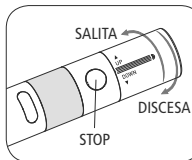
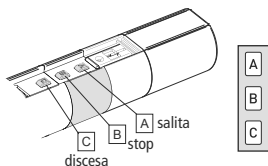

## CARATTERISTICHE TECNICHE

- Alimentazione	230 V / 50 Hz
- Potenza assorbita	0,5 W
- Frequenza radio	433,92 MHz
- Codifica	Rolling Code
- Modulazione	AM/ASK
- Num. max trasmettitori	15
- Potenza max motore	300 W
- Temperatura di funzionamento	-10 C° +55 C°
- Dimensioni	40x40x20 mm
- Peso	80 gr
- Grado di protezione	IP44

# SPIEGAZIONE DELLE SEQUENZE DI COMANDO

La maggior parte delle sequenze di comando è composta da tre passi ben distinti, al termine dei quali il motore segnala, con diversi tipi di rotazione, se il passo si è concluso in modo positivo o negativo. Lo scopo di questo paragrafo è quello di riconoscere le segnalazioni del motore.

I tasti devono essere premuti come indicato nella sequenza, senza far passare più di 4 secondi tra un passo e l'altro. Se trascorrono più di 4 secondi, il comando non viene accettato, e si dovrà ripetere la sequenza.

Esempio di sequenza di comando:

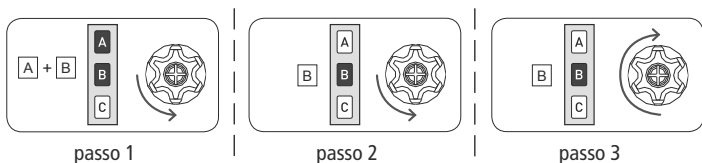

Come si vede nell'esempio, quando la sequenza termina in maniera positiva il motore si riporta nella posizione iniziale con una singola rotazione lunga. Infatti due brevi rotazioni nello stesso senso corrispondono ad una rotazione lunga nel senso opposto. Il motore si riporta nella posizione iniziale anche quando la sequenza non viene completata, in questo caso effettuando una o due brevi rotazioni.

Esempi di sequenze incomplete:

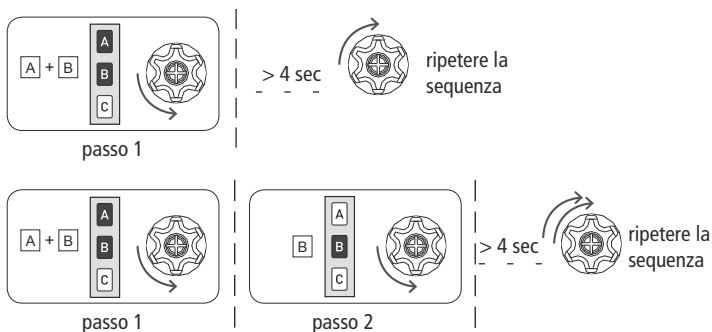

# II FUNZIONE APERTURA/CHIUSURA PROGRAMMAZIONE TELECOMANDO TM2 X T

Per evitare modifiche accidentali alla programmazione del motore durante l'uso quotidiano del telecomando, la possibilità di programmazione viene disabilitata automaticamente dopo 8 ore dall'invio dell'ultima sequenza (A+B o B+C).

## VERIFICA DELLO STATO DELLA FUNZIONE

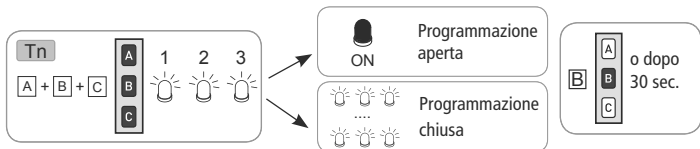

Per modificare lo stato della funzione vedi le sequenze abilitazione/disabilitazione

## ABILITAZIONE DELLA PROGRAMMAZIONE

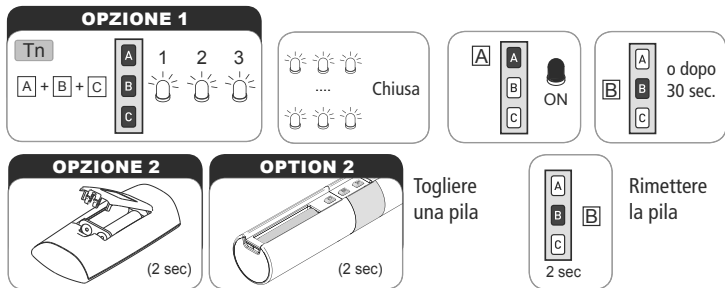

Procedere con la programmazione come da libretto istruzioni

## DISABILITAZIONE DELLA PROGRAMMAZIONE

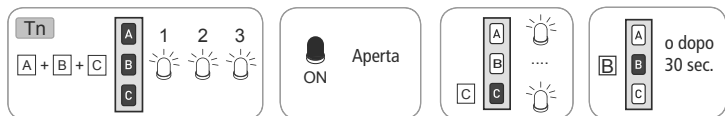

# MEMORIZZAZIONE PRIMO TELECOMANDO

Questa operazione può essere eseguita solamente quando la centralina è nuova, oppure dopo una cancellazione completa della memoria.

**Durante questa fase alimentare una sola centralina per volta.**

T1: Primo telecomando da memorizzare

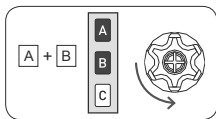

T1

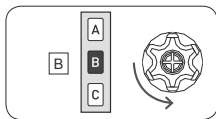

T1

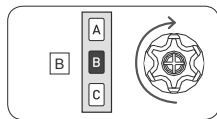

T1 (2 sec)

## FUNZIONE DISABILITAZIONE AUTOMATICA MEMORIZZAZIONE PRIMO TELECOMANDO

Ad ogni accensione della centralina si hanno a disposizione 3 ore per memorizzare il primo telecomando. Trascorso questo tempo la possibilità di memorizzare il telecomando viene disabilitata. Per azzerare il timer della funzione è sufficiente togliere e ridare alimentazione alla centralina.

## IMPOSTAZIONE DEL SENSO DI ROTAZIONE DEL MOTORE

Eeguire questa operazione quando la rotazione del motore non è coerente con i tasti del telecomando, per esempio se attivando la funzione SALITA (UP), la tenda o la tapparella scende.

È necessario impostare il senso di rotazione corretto se alla centralina è associato un anemometro. In caso di allarme vento, la centralina esegue sempre il comando associato al tasto "SU".

Impostazione del senso di rotazione utilizzando il tasto SET:

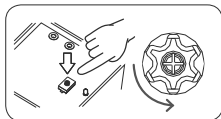

max 2 sec

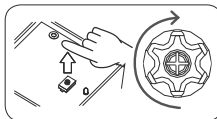

Il senso di rotazione può essere invertito anche scambiando tra loro i fili marrone e nero sulla morsetteria del motore.

L'impostazione del senso di rotazione viene mantenuta anche dopo una cancellazione completa della memoria.

# MEMORIZZAZIONE DI ALTRI TELECOMANDI

È possibile memorizzare fino a 15 telecomandi compreso il sensore luce/vento.

Tn: Telecomando memorizzato

Tx: Telecomando da memorizzare

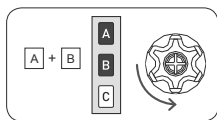

Tn

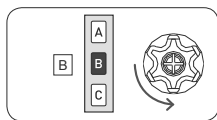

Tn

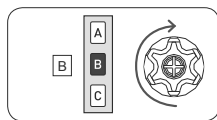

Tx (2 sec)



## CANCELLAZIONE SINGOLO TELECOMANDO

È possibile cancellare singolarmente ogni telecomando memorizzato. Nel momento in cui si cancella l'ultimo la centralina si riporta nella condizione iniziale. La stessa cosa vale per i singoli canali nel telecomando multicanale, basta selezionare il canale da cancellare prima di eseguire la sequenza.

Tn: Telecomando da cancellare

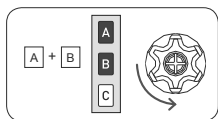

Tn

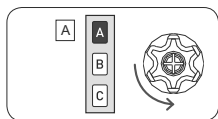

Tn

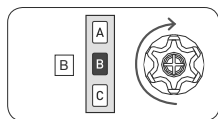

Tn (2 sec)

## CANCELLAZIONE TOTALE DELLA MEMORIA TELECOMANDI

La cancellazione totale della memoria si può effettuare in due modi:

1) CON IL TELECOMANDO

Tn: Telecomando memorizzato

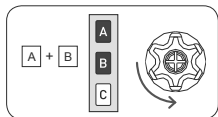

Tn

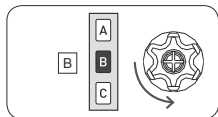

Tn

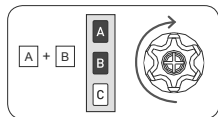

Tn (4 sec)

2) CON IL TASTO SET

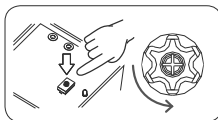

circa 8 sec

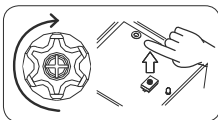

## AZIONAMENTO DA TELECOMANDO

### Telecomando Serie TM2 X T

- Ruotando verso UP si comanda la salita;
- Il tasto STOP interrompe il comando;
- Ruotando verso DOWN si comanda la discesa.

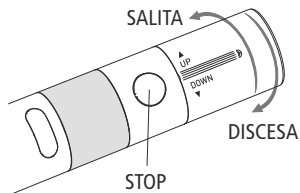

# COMANDO FILARE OPZIONALE

In aggiunta al telecomando, è possibile comandare l'avvio e l'arresto del motore con un commutatore o un pulsante, collegato via filo all'ingresso del comando filare opzionale (filo bianco).

La centralina può essere programmata per operare con commutatori e pulsanti in modalità "uomo presente" (DM) oppure "moto continuo" (MC).

## MODALITÀ "UOMO PRESENTE" (DM)

I comandi di salita e discesa rimangono attivi fintanto che il contatto è chiuso, rispettando comunque il time-out di 3 minuti. Per fermare il motore posizionare il commutatore su Stop.

## MODALITÀ "MOTO CONTINUO" (MC)



È sufficiente un breve impulso di salita o discesa per attivare le uscite con il time-out fisso di 3 minuti. Per fermare il motore premere nuovamente salita o discesa.

## CAMBIO DI MODALITÀ DA DM A MC E VICEVERSA

La centralina è preimpostata in fabbrica per la modalità DM. Per effettuare il cambio dalla modalità DM a quella MC effettuare i seguenti passaggi:

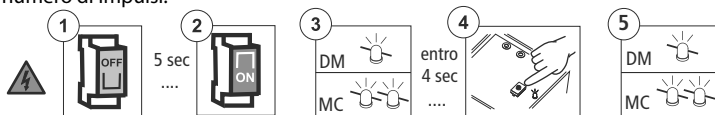
- 1) Togliere l'alimentazione e aspettare 5 secondi.
- 2) Ridare l'alimentazione.
- 3) Attendere la segnalazione del led che indica la modalità attuale:
  - 1 impulso per la modalità DM.
  - 2 impulsi per la modalità MC.
- 4) Entro 4 secondi premere il tasto SET: il led segnala la nuova modalità con il relativo numero di impulsi.



CAMBIO MODALITÀ		
	DM	MC
 PULSANTE (passo-passo)	NO	✓
 COMMUTATORE (Su/Giù)	✓	✓

Se si collega un commutatore, la centralina si imposta automaticamente per l'utilizzo dei comandi su/giù.

Se in seguito si sostituisce il commutatore con un pulsante, per tornare al funzionamento passo-passo inviare la seguente sequenza.

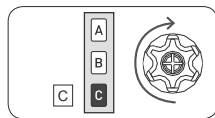
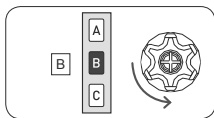
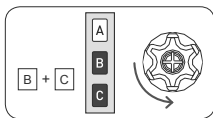

2 sec

## ESEMPIO DI COMANDO FILARE CON COMMUTATORE SU/GIÙ

Collegare il comune del commutatore all'ingresso del comando filare opzionale (filo bianco) e i due terminali di commutazione uno alla Fase e l'altro al Neutro dell'alimentazione.

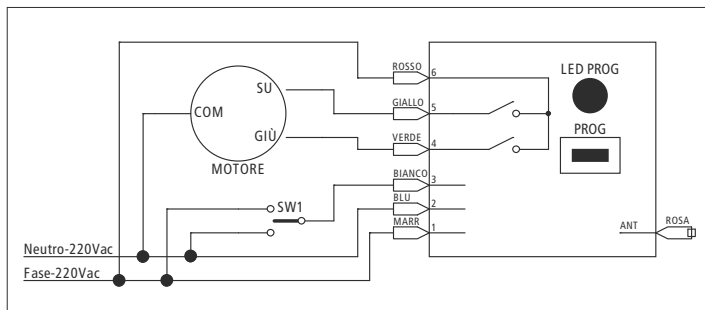

Comando motore radio + filare da commutatore su/giù

## ESEMPIO DI COMANDO FILARE CON PULSANTE

In questa configurazione non è possibile utilizzare la modalità "DM".

Impostare la centralina per la modalità moto continuo (MC) e collegare il pulsante tra Fase e ingresso del comando filare opzionale (filo bianco).

Ad ogni pressione del pulsante, si ha la funzionalità passo-passo: salita-stop-discesa-stop.

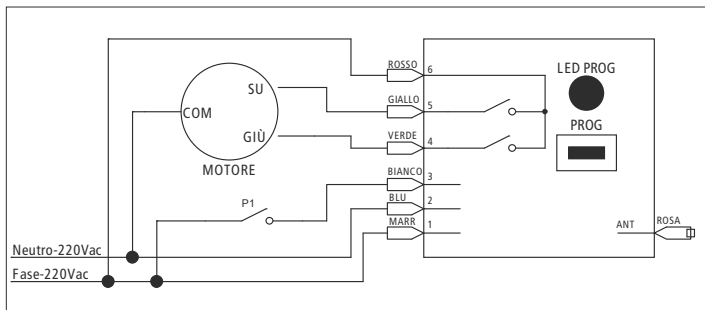

Comando motore radio + filare da pulsante passo/passo

## FUNZIONAMENTO CON SENSORE SOLE/VENTO

È possibile associare un sensore vento o sole/vento alla centralina. In corrispondenza degli eventi climatici di comparsa/scomparsa del sole e/o in presenza di allarme vento, la centralina esegue le seguenti operazioni:

Evento	Automatismo
Comparsa del sole (luce sopra soglia)	Dopo 3 minuti dalla comparsa del sole, la tenda da sole si apre completamente.
Scomparsa del sole (luce sotto soglia)	Dopo 10 minuti dalla scomparsa del sole, la tenda da sole si chiude completamente.
Allarme vento (vento sopra soglia)	Dopo 2 secondi, la tenda da sole si chiude completamente e non è possibile azionarla fino a dopo 8 minuti che la velocità del vento sia tornata sotto soglia. Il led rosso lampeggia.

## SENSORE TM2 X W

Rileva le oscillazioni indotte dal vento sulla struttura a bracci.

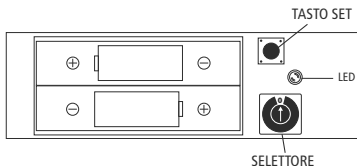
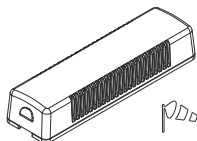

### MEMORIZZAZIONE SENSORE

Per realizzare l'associazione del sensore alla centralina è necessario aver già memorizzato un telecomando. Portare il selettore sulla posizione 0 ed eseguire la seguente sequenza:

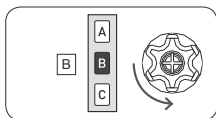
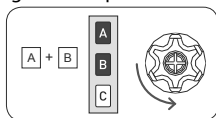

2 sec

### CANCELLAZIONE SENSORE

Per cancellare l'associazione del sensore alla centralina è necessario un telecomando già memorizzato. Portare il selettore sulla posizione 0, se attivo attendere lo spegnimento del sensore, ed eseguire la seguente sequenza:

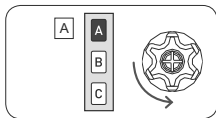
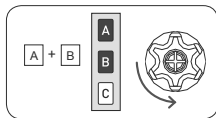

2 sec

Per la descrizione completa delle funzioni di questo dispositivo consultare il libretto istruzioni inserito nella confezione.

# ANEMOMETRI

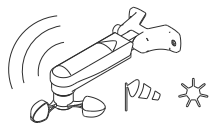

TM2 X SW

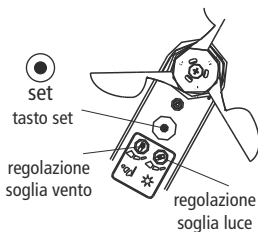

## MEMORIZZAZIONE

Per realizzare l'associazione del sensore alla centralina è necessario aver già memorizzato un telecomando. La sequenza di memorizzazione è la seguente:

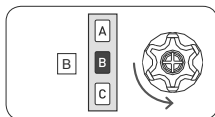
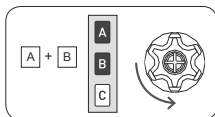

2 sec

## CANCELLAZIONE

Per cancellare l'associazione del sensore alla centralina è necessario un telecomando già memorizzato. La sequenza di cancellazione è la seguente:

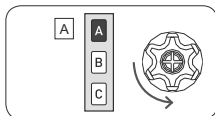
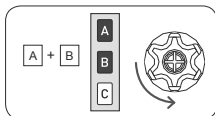

2 sec

Per la descrizione completa delle funzioni di questi dispositivi consultare il libretto istruzioni inserito nella confezione.

## ATTIVAZIONE/DISATTIVAZIONE DELLA FUNZIONE LUCE

(TM2 X SW)

Per attivare (automatico) o disattivare (manuale) la funzione luce fare riferimento al manuale istruzioni in dotazione con il sensore o telecomando che si intende utilizzare.

### TEST PER ANEMOMETRO TIPO TM2 X SW

Questa funzione è utile per verificare la corretta comunicazione via radio e per effettuare la prova delle funzioni vento e luce.

Per attivare la funzione di TEST, tenere premuto il tasto SET (circa 2 sec), finché la tenda si apre per 10 secondi e con una breve chiusura segnala che il test è attivo. La funzione di test resta attiva per 3 minuti, durante i quali è possibile verificare l'impostazione delle soglie vento e luce, senza attendere i tempi di attivazione. Dopo 3 minuti, il sensore TM2 X SW ritorna a funzionare in modo normale. Durante il test il led rosso all'interno della centralina rimane acceso.

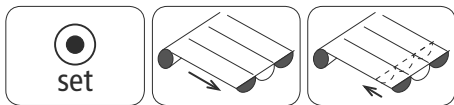

2 sec

#### PROVA DELLA FUNZIONE VENTO

Per evitare errori durante la prova della funzione vento, si raccomanda di disattivare la funzione luce. Facendo muovere le pale dell'anemometro, quando la velocità rilevata dal sensore supera la soglia impostata, il motore comanda la chiusura della tenda.

#### PROVA DELLA FUNZIONE LUCE

Assicurarsi che la funzione luce sia attiva. Quando il sensore rileva una variazione dell'intensità della luce, apre la tenda se l'intensità della luce va al di sopra della soglia impostata, oppure chiude la tenda se l'intensità della luce va al di sotto della soglia impostata. È possibile ripetere più volte questo test, per regolare al meglio la soglia desiderata.



## FUNZIONI SPECIALI

# MEMORIZZAZIONE TEMPORANEA TELECOMANDO

Questa funzione permette di memorizzare un telecomando in modo temporaneo, ad esempio in modo da permettere l'impostazione dei finecorsa durante il montaggio in fabbrica. Il telecomando definitivo potrà essere memorizzato in seguito con l'apposita sequenza di comando (vedi "MEMORIZZAZIONE PRIMO TELECOMANDO").

Le operazioni descritte di seguito possono essere eseguite solo quando la centralina è nuova di fabbrica, oppure dopo una cancellazione totale della memoria (vedi "CANCELLAZIONE TOTALE DELLA MEMORIA TELECOMANDI"). Per assicurare che la programmazione temporanea sia utilizzata solo in fase di installazione o regolazione, e non durante l'uso quotidiano, la centralina permette le seguenti operazioni solo nei limiti di tempo descritti. Alimentare la centralina, assicurarsi che nel raggio di azione del telecomando non siano presenti altre centraline alimentate e con la memoria vuota.

**Entro 30 secondi dall'accensione**, premere contemporaneamente i tasti B e C, finché il motore collegato effettua la segnalazione di conferma.

**Il telecomando rimarrà memorizzato per 5 minuti**, mentre la centralina è alimentata. Passati 5 minuti, o togliendo tensione alla centralina, il telecomando sarà cancellato.

T1: Primo telecomando da memorizzare

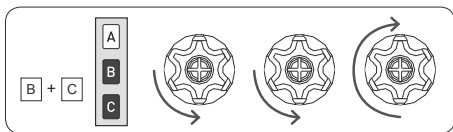

T1

## DICHIARAZIONE DI CONFORMITÀ EU

Il fabbricante, FAAC S.p.A. Soc. Unipersonale, dichiara che il tipo di apparecchiatura radio marca FAAC modello TM2 X R MINI è conforme alle pertinenti normative di armonizzazione dell'Unione: Direttiva 2014/53/EU, Direttiva 2011/65/EU.

Il testo completo della dichiarazione di conformità EU è disponibile al seguente indirizzo Internet: **<http://www.faac.biz/certificates>**

Bologna, 17-09-2018

A handwritten signature in black ink, appearing to read 'P. M...' with a stylized flourish at the end.

# CONTENTS

SAFETY INSTRUCTIONS .....	20
ELECTRICAL CONNECTIONS .....	20
KEY TO SYMBOLS .....	21
TECHNICAL FEATURES .....	21
COMMAND SEQUENCES EXAMPLE .....	22
FUNCTION OPEN/CLOSE PROGRAMMING REMOTE CONTROL SERIES TM2 X T .....	23
SETTING THE FIRST REMOTE CONTROL .....	24
SETTING THE ROTATION DIRECTION OF THE MOTOR .....	24
SETTING OF ADDITIONAL REMOTE CONTROLS .....	25
REMOTE CONTROL MEMORY CLEARING .....	26
FULL MEMORY CLEARING .....	26
ACTIVATION BY REMOTE CONTROL .....	27
OPTIONAL WIRED SWITCH .....	28
OPERATION WITH SUN/WIND SENSOR .....	30
TM2 X W SENSOR .....	31
ANEMOMETERS .....	32
SHORT-TERM SETTING OF A REMOTE CONTROL .....	34
EU DECLARATION OF CONFORMITY .....	35

# SAFETY INSTRUCTIONS

- Only professional technicians must perform installation, complying with all safety instructions, especially those regarding electrical connections.
- To avoid short circuits, arrange an automatic bipolar switch with opening distance of the contacts of at least 3 mm before the circuit.
- If not used, the white wire must be insulated. It is dangerous to touch the white wire when the motor is powered.

# ELECTRICAL CONNECTIONS

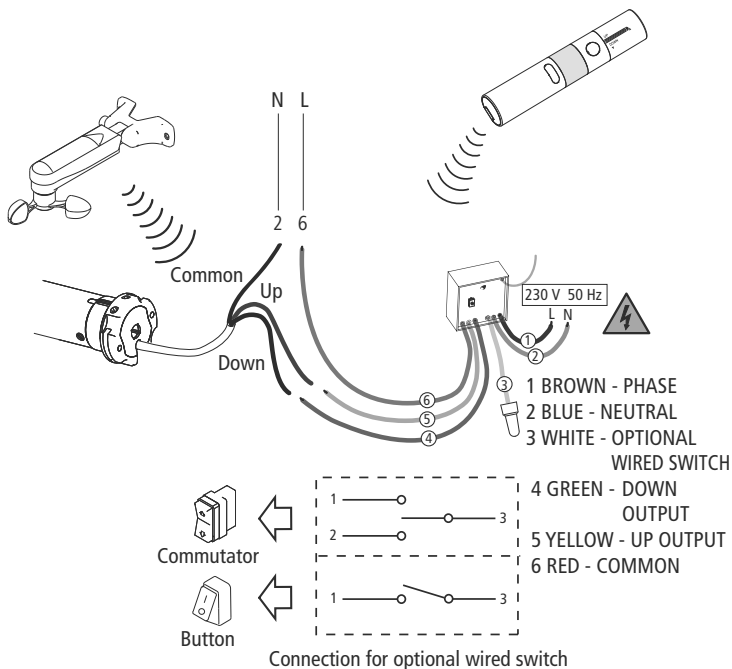

# KEY TO SYMBOLS

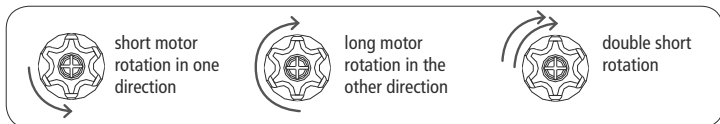
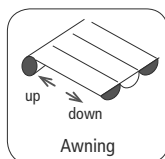
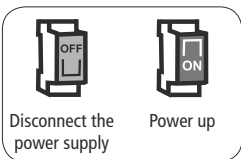
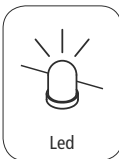
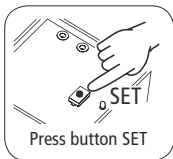
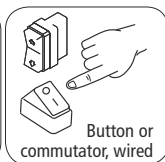
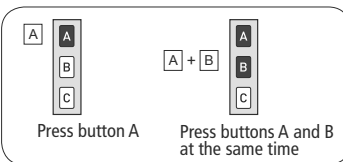
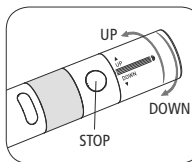
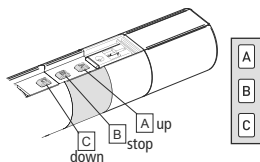

## TECHNICAL FEATURES

- |                                     |               |
|-------------------------------------|---------------|
| - Power supply                      | 230 V / 50 Hz |
| - Power consumption                 | 0,5 W         |
| - Radio Frequency                   | 433,92 MHz    |
| - Decoder System                    | Rolling Code  |
| - Modulation                        | AM/ASK        |
| - Max. number storable transmitters | 15            |
| - Max. motor power                  | 300 W         |
| - Operating temperature             | -10 C° +55 C° |
| - Dimensions                        | 40x40x20 mm   |
| - Weight                            | 80 gr         |
| - Protection degree                 | IP44          |

# COMMAND SEQUENCES EXAMPLE

Most of the command sequences have three distinct steps, at the end of which the motor indicates if the step has been concluded positively or not, by turning in different ways. This section is provided to demonstrate the motor indications. The buttons must be pressed as shown in the sequence, without taking more than 4 seconds between one step and the next. If more than 4 seconds are taken, the command is not accepted and the sequence must be repeated.

Command sequence example:

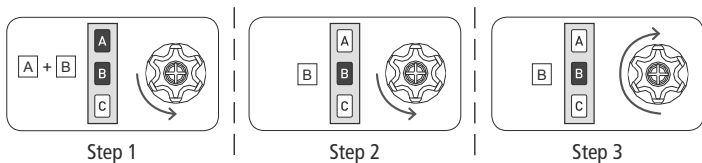

As we can see from the example, when the sequence ends positively, the motor returns to its starting position in one long rotation. In fact, two short rotations in the same direction correspond to one long rotation in the opposite direction. The motor returns to the starting position even when the sequence is not completed; in this case by performing one or two short rotations.

Example of a wrong sequence:

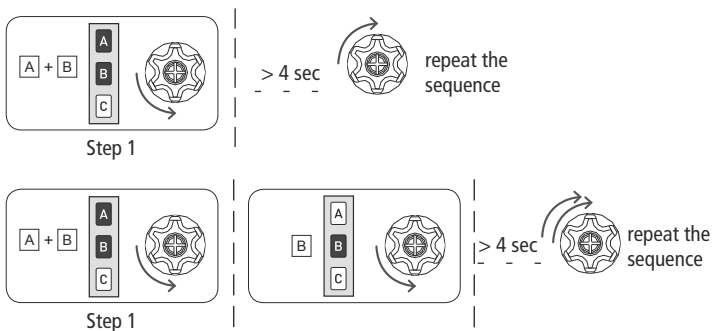

# FUNCTION OPEN/CLOSE PROGRAMMING REMOTE CONTROL SERIES TM2 X T

To prevent accidental changes to the programming of the motor during the daily use of the remote control, the possibility of programming is disabled automatically 8 hours after sending the last sequence (A+B or B+C).

## CHECKING THE STATUS OF THE FUNCTION

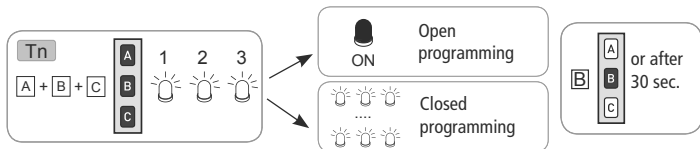

To change the status of the function, see the sequences "enable/disable programming"

## ENABLE PROGRAMMING

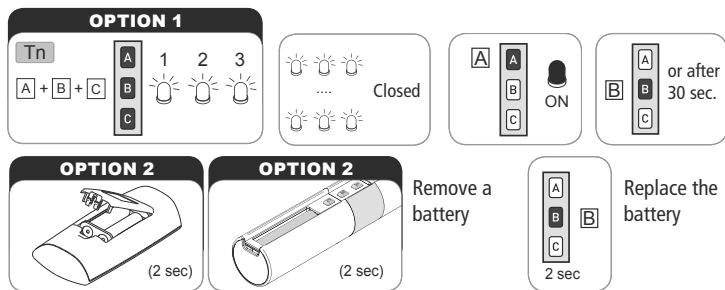

Proceed with programming as the instructions booklet

## DISABLE PROGRAMMING

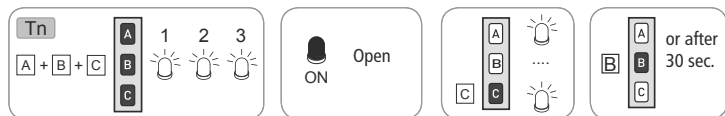

# SETTING THE FIRST REMOTE CONTROL

This operation can only be performed when the control unit is new, or after a total delete of the memory.

**During this step, power up only one control unit at time!**

T1: First remote control to be set

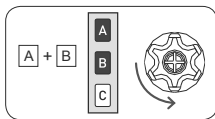

T1

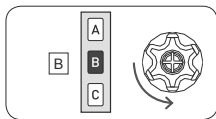

T1

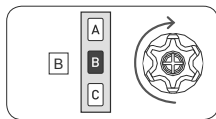

T1 (2 sec)

## AUTOMATIC DISABLING OF THE FIRST REMOTE CONTROL SETTING FUNCTION

Every time you connect the power supply to the control unit, you have 3 hours to store the first remote control. After this time, the ability to store the remote control is disabled. To reset the timer of the function you have to disconnect and reconnect the power supply to the control unit.

# SETTING THE ROTATION DIRECTION OF THE MOTOR

This operation is mandatory if the rotation direction of the motor does not match to the UP and DOWN functions of the remote control as an exemple if giving up command the awning or blinds descend.

The proper motor direction must be set, if the motor is linked to a Wind sensor. In case of a wind alarm, the motor will always perform the command associated to the UP button.

Setting the rotation direction using the SET button:

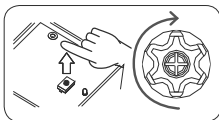
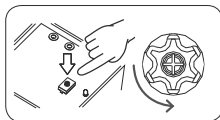

max. 2 sec

Interchanging the BROWN and BLACK motor wire on the terminals of the control unit, will also reverse the rotation direction.

**The control unit will keep this setting even after complete memory clearing.**



# SETTING OF ADDITIONAL REMOTE CONTROLS

Up to 15 remote controls can be set, including the light/wind sensor.

Tn: Already programmed remote control

Tx: Additional remote control

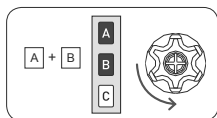

Tn

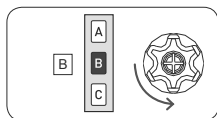

Tn

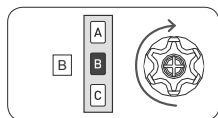

Tx (2 sec)

# REMOTE CONTROL MEMORY CLEARING

It is possible to delete singly all the memorized remote controls. When the last one is deleted the control unit initial condition is restored. The same applies to the single channels of a multichannel remote control: just select the channel to cancel.

Tn: Remote control to be cleared

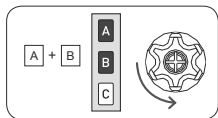

Tn

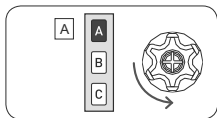

Tn

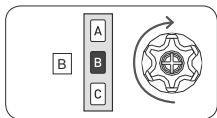

Tn (2 sec)

## FULL MEMORY CLEARING

The full memory clearing can be performed in two ways:

### 1) WITH THE REMOTE CONTROL

Tn: Already programmed remote control

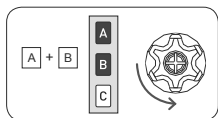

Tn

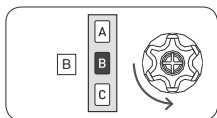

Tn

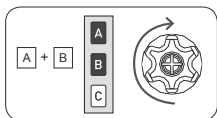

Tn (4 sec)

### 2) WITH THE SET BUTTON

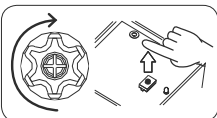
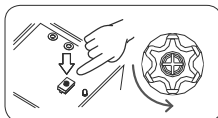

approximately 8 sec

## ACTIVATION BY REMOTE CONTROL

- Turning to wards UP control the ascent;
- Button STOP interrupts the command;
- Turning to wards DOWN control the descent.

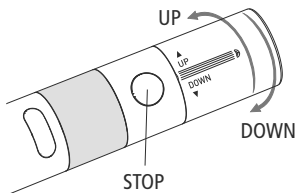

# OPTIONAL WIRED SWITCH

In addition to the remote control, it is possible to control motor start and stop with a commutator or a button, connected to the optional wired switch (white wire).

The control unit may be programmed to operate with commutators and buttons in "dead man mode" (DM) or "latching mode" (MC).

## DM - DEAD MAN MODE

The up and down controls remain active as long as the contact is closed, in any case complying with the 3 minute time-out. To stop the motor set the commutator to Stop.

## MC - LATCHING MODE

A short up or down impulse is enough to activate the outputs with the time-out set at 3 minutes. To stop the motor, press up or down again.

## MODE CHANGE FROM DM TO MC AND VICE VERSA

The control unit is set at the factory for the DM mode. To change from the DM Mode to the MC Mode, do the following:

- 1) Disconnect the power, and wait at least 5 seconds.
- 2) Reconnect the power.
- 3) Stand by for the Led signal that indicates the current mode:
  - 1 impulse for the DM Mode.
  - 2 impulses for the MC Mode.
- 4) Within 4 seconds press the SET button: the Led shows the new mode with the relative number of impulses.

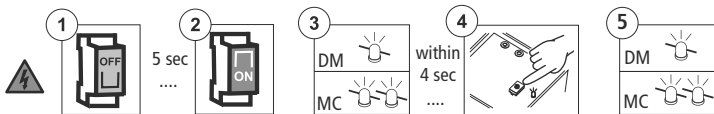

MODE CHANGE		
	DM	MC
 BUTTON (step-by-step)	NO	✓
 COMMUTATOR (Up/Down)	✓	✓

If a commutator is connected, the control unit is automatically set for use of the up/down controls.

If you then replace the switch with a button, to return to the step-by-step mode run the following sequence.

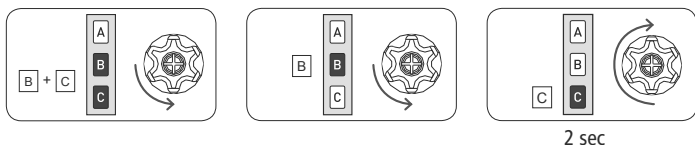

## WIRED CONTROL WITH UP/DOWN COMMUTATOR

Connect the commutator common to the optional wired switch (white wire) input and one of the two commutation terminals to the Phase and the other one to the Neutral of the power supply.

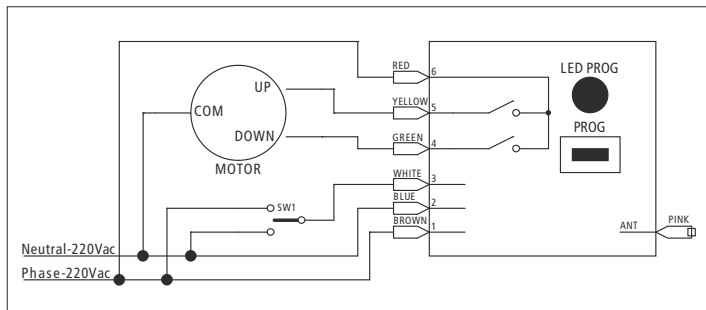

Remote and wired control of the motor with up/down commutator

## WIRED CONTROL WITH BUTTON

In this setup it is not possible to use the DM mode.

Set the control unit to the latching mode (MC) and connect the button between Phase and the input of the optional wired switch (white wire).

Each time the button is pressed the control unit works in step-by-step mode: up-stop-down-stop.

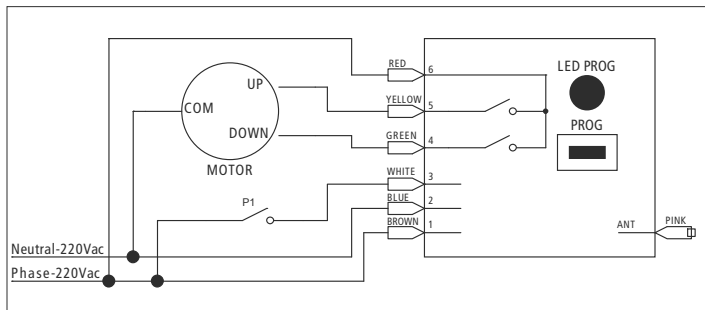

Remote and wired control of the motor with step-by-step button

## OPERATION WITH SUN/WIND SENSOR

It is possible to associate a wind or sun/wind sensor with the control unit. In correspondence to climatic events, the appearance or disappearance of the sun and/or with a wind alarm, the control unit performs the following operations:

Event	Automatic movement
Appearance of the sun (sunlight over threshold level)	3 minutes after the sun comes out, the awning opens completely.
Disappearance of the sun (sunlight under threshold level)	10 minutes after the sun disappears, the awning closes completely.
Wind alarm (wind over the threshold speed)	After 2 seconds, the awning closes completely. It is not possible to open it until 8 minutes have passed with the wind under the threshold speed. The red Led flashes.

## COMPATIBLE DEVICES

### TM2 X W SENSOR

It detects movements caused by the wind on the awning arms.

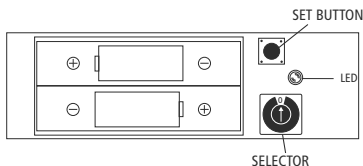
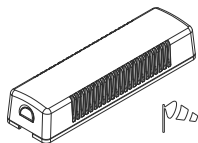

### SETTING THE SENSOR

To associate the sensor to the control unit, a remote control must be already memorized. Set the selector to the 0 position and then perform this sequence:

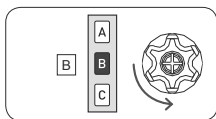
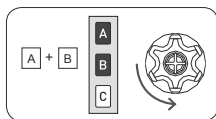

2 sec

### DELETING THE SENSOR

To delete the sensor from the control unit, an already programmed remote control must be used. Set the selector to the 0 position; if active wait for the sensor to go off and then perform this sequence:

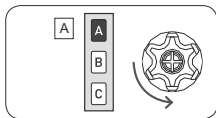
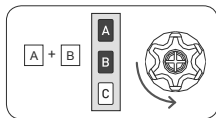

2 sec

For the complete description of the functions of this device see the instruction booklet that came in the box.

# ANEMOMETERS

EN

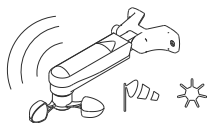

TM2 X SW

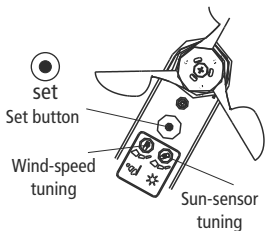

## SETTING

To associate the sensor to the control unit, a remote control must be already memorised. The setting sequence is the following:

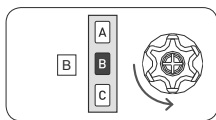
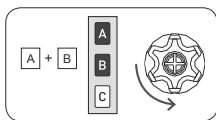

2 sec

## DELETING

To delete the sensor from the control unit, an already programmed remote control must be used. The deleting sequence is the following:

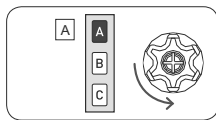
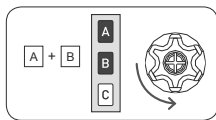

2 sec

For the complete description of the functions of these devices see the instruction booklet that came in the box.



## ENABLE / DISABLE THE SUN SENSOR

(TM2 X SW)

To enable (automatically) or disable (manually) the sun sensor refer to the instruction manual provided with the sensor or the remote control you want to use.

### TEST MODE FOR TM2 X SW

This function is useful to check the correct communication via radio, and perform the wind and sun function test.

To activate the TEST function, hold the SET button down for around 2 seconds, until the awning opens for 10 seconds and closes briefly to confirm that the test mode is activated. The Test function lasts for 3 minutes, during which the wind and light level settings can be checked, without waiting for the activation times. After 3 minutes, the TM2 X SW sensor returns to normal mode function. During the wind-alarm the red led inside the control unit is on.

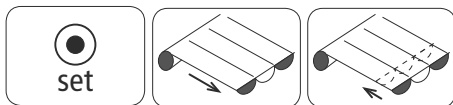

2 sec

#### WIND FUNCTION TEST

To avoid errors during the wind function test, it is suggested that the sunlight function be deactivated. By spinning the anemometer fins, when the speed detected by the sensor exceeds the threshold set, the motor will close completely the awning.

#### SUN FUNCTION TEST

Make sure that the sunlight function is on. When the sensor detects a change in the sunlight intensity, it opens the awning if brighter than the set point or closes it if weaker. This test can be repeated several times to establish the desired automatic opening and closing level according to the light.

## SHORT-TERM SETTING OF A REMOTE CONTROL

EN

This function makes it possible to store a remote control temporarily, for example, with the purpose of setting the limit switches during assembly in the factory. A later final saving of the remote control will be possible using the appropriate command sequence (see: "SETTING THE FIRST REMOTE CONTROL"). The operations described below can be carried out only when the control unit has just come out of the factory or after a full memory clearing (see: "FULL MEMORY CLEARING"). The control unit makes the following operations possible only within the time limits described in order to make sure that the short-term setting is used only in the installation or factory setting phase and not during daily use. Power up the control unit, make sure that no other control units having an empty memory are powered up in the same operating range.

**Within 30 seconds after start**, press the B and C buttons simultaneously until the motor gives a confirmation signal.

**The remote control will remain stored for 5 minutes**, while the control unit is powered up. After 5 minutes or when the control unit has its power cut off, the remote control will be cancelled.

T1: First remote control to be set

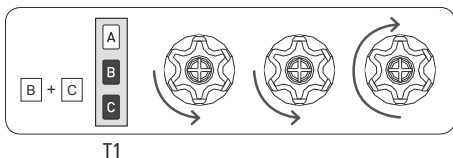

## EU DECLARATION OF CONFORMITY

The manufacturer, FAAC S.p.A. Soc. Unipersonale, hereby, declares that the FAAC model TM2 X R MINI radio equipment is in compliance with Directive 2014/53/EU, Directive 2011/65/EU.

The full text of the EU declaration of conformity is available at the following Internet address: **<http://www.faac.biz/certificates>**.

Bologna, 17-09-2018

CEO A. Marcellan



# INHALTSVERZEICHNIS

SICHERHEITSVORSCHRIFTEN .....	37
ELEKTRISCHE ANSCHLÜSSE .....	37
SYMBOLERKLÄRUNG .....	38
TECHNISCHE EIGENSCHAFTEN .....	38
EINGABE DER BEFEHLSFOLGEN .....	39
FUNKTION ÖFFNEN/SPERREN DER PROGRAMMIERUNG HANDSENDER BAUREIHE TM2 X T .....	40
EINSTELLUNG DES ERSTEN HANDSENDERS .....	41
EINSTELLUNG DER DREHRICHTUNG DES MOTORS .....	41
EINSTELLUNG ZUSÄTZLICHER HANDSENDER .....	42
LÖSCHEN EINES EINZELNEN HANDSENDERS .....	43
LÖSCHEN ALLER GESPEICHERTEN EINSTELLUNGEN .....	43
BETÄTIGUNG ÜBER HANDSENDER .....	44
OPTIONALER TASTERANSCHLUSS .....	45
FUNKTION MIT WINDWÄCHTER-SONNENSSENSOR .....	47
WETTERSTATION TM2 X W .....	48
WINDWÄCHTER .....	49
KURZZEITIGE EINLERNUNG DES HANDSENDERS .....	51
EU-KONFORMITÄTSERKLÄRUNG .....	52

# SICHERHEITSVORSCHRIFTEN

- Unter Einhaltung aller Sicherheitsnormen, muss die Installation der elektrischen Anschlüsse durch geschultes Fachpersonal durchgeführt werden.
- Um Kurzschlüsse zu vermeiden, muss vom Netz aus eine automatische allpolige Trennung, mit Kontaktöffnungsweite von mindestens 3 mm vorgesehen werden.
- Wenn nicht gebraucht, weißen Draht isolieren. Es ist gefährlich, den weißen Draht zu berühren, wenn der Motor unter Strom ist.

# ELEKTRISCHE ANSCHLÜSSE

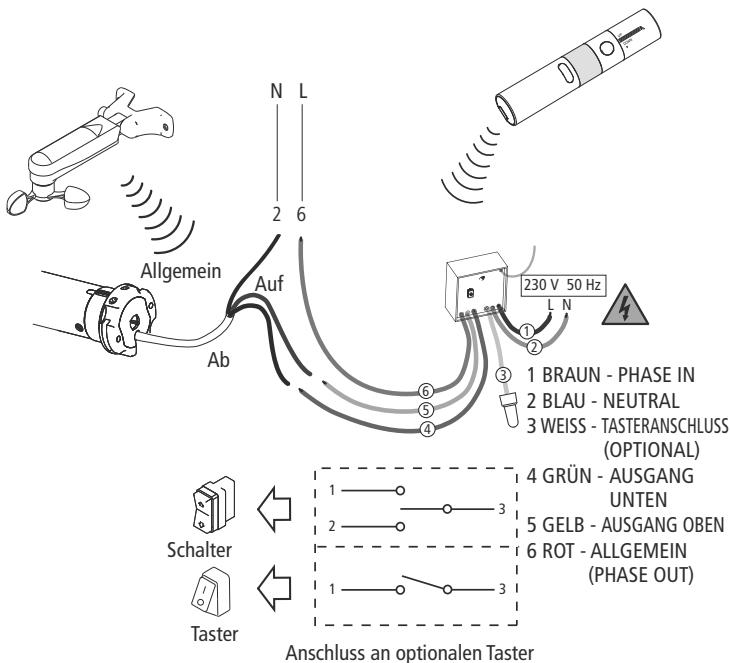

# SYMBOLERKLÄRUNG

DE

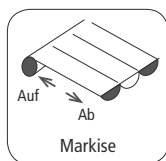
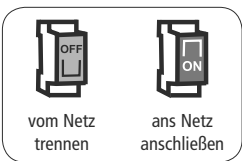
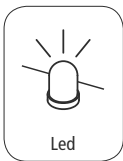
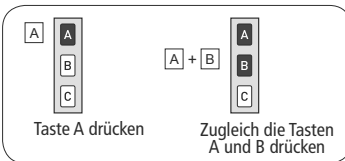
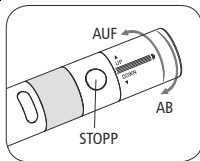
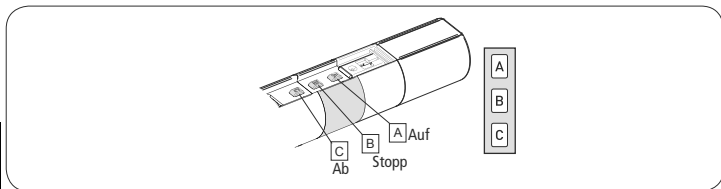

## TECHNISCHE EIGENSCHAFTEN

- Spannung 230 V / 50 Hz
- Leistungsaufnahme 0,5 W
- Funkfrequenz 433,92 MHz
- Decoder System Rolling Code
- Modulation AM/ASK
- Max. einstellbare Handsender 15
- Max. Motor Leistung 300 W
- Betriebstemperatur -10 C° +55 C°
- Abmessungen 40x40x20 mm
- Gewicht 80 gr
- Schutzgrad IP44

# EINGABE DER BEFEHLSFOLGEN

Die meisten Befehlsfolgen entsprechen drei klar unterschiedlichen Schritten, bei deren Ende der Motor, mit unterschiedlichen Drehungen, anzeigt ob die Eingabe erfolgreich war oder misslungen ist. Hier werden die vom Motor gegebenen Signale erläutert.

Die Tasten müssen wie unten beschrieben gedrückt werden und es dürfen nicht mehr als 4 Sekunden von einem Schritt zum anderen verstreichen. Sollten mehr als 4 Sekunden verstreichen, wird die Befehlsfolge nicht akzeptiert und man muss diese wiederholen.

Beispiel einer Befehlsfolge:

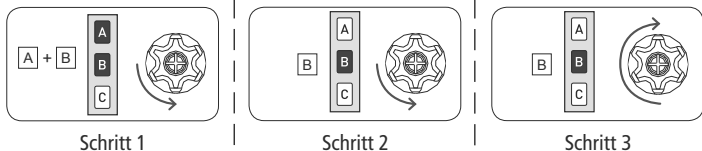

Bei positiv abgeschlossener Befehlsfolge, wie auf obigem Beispiel dargestellt, kehrt der Motor nach zwei kurzen Drehungen, mit einer langen Drehung wieder auf die Startposition zurück. Zwei kurze Drehungen in eine Richtung entsprechen der langen Drehung in die entgegengesetzte Richtung. Bei unvollständiger Befehlsfolge kehrt der Motor, nach 1 oder 2 kurzen Drehungen, in die Startposition zurück.

Beispiel einer unvollständigen Befehlsfolge:

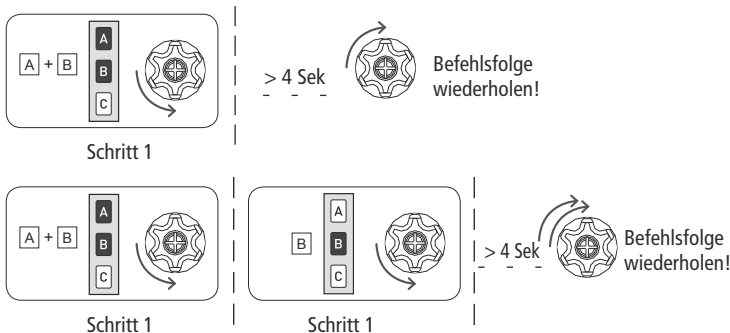

# FUNKTION ÖFFNEN/SPERREN DER PROGRAMMIERUNG HANDSENDER BAUREIHE TM2 X T

Zur Meidung von Fehlprogrammierungen während der täglichen Bedienung, wird nach 8 Stunden ab Eingabe der letzten Befehlsfolge (A+B oder B+C) der Programmiermodus automatisch gesperrt.

## ABFRAGE DES PROGRAMMIERMODUS

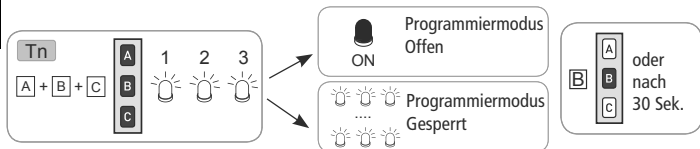

Zur Änderung des Programmiermodus, "Öffnen/Sperren" wie hier folgend geschildert vorgehen

## PROGRAMMIERMODUS "ÖFFNEN"

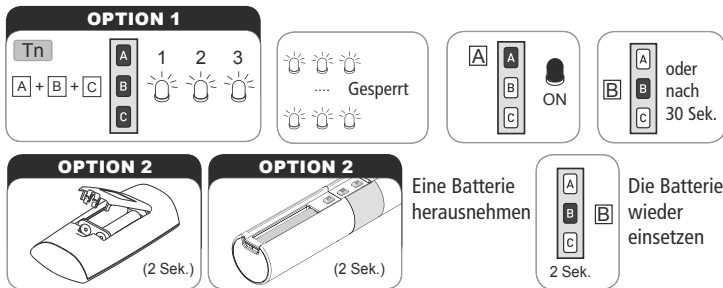

Wie auf der Anleitung beschrieben mit der Programmierung vorg

## PROGRAMMIERMODUS "SPERREN"





# EINSTELLUNG DES ERSTEN HANDSENDER

Diese Operation kann ausschließlich bei einem neuen Funkempfänger oder nach totaler Löschung aller Programmierungen ausgeführt werden.

**Während dieser Operation immer nur einen Funkempfänger unter Spannung halten!**

T1: Erster, einzustellender Handsender

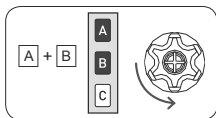

T1

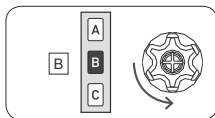

T1

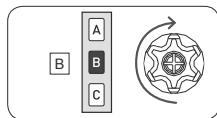

T1 (2 Sek)

## FUNKTION AUTOMATISCHE DEAKTIVIERUNG DER EINLERNUNG DES ERSTEN HANDSENDER

Jedes Mal wenn der Funkempfänger von Netz getrennt und wieder verbunden wird, hat man 3 Stunden Zeit um den ersten Handsender einzulernen. Nach 3 Stunden wird dieser Programmiermodus deaktiviert. Um den Programmiermodus wieder zu aktivieren, genügt es den Funkempfänger kurz vom Netz zu trennen.

## EINSTELLUNG DER DREHRICHTUNG DES MOTORS

Wenn die Drehrichtung nicht mit den Tasten des Handsenders, z.B. mit Funktion AUF (UP) einig ist und die Markise oder Rolllade abgeht, folgende Operation durchführen.

Wenn dem Funkempfänger ein Windwächter zugeordnet ist, muss die korrekte Drehrichtung zwingend eingestellt werden. Im Falle eines Windalarms führt der Funkempfänger den Befehl in Zuordnung zur Auf-Taste.

Einstellen der Drehrichtung mittels der SET Taste:

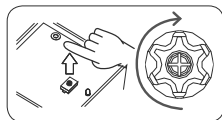
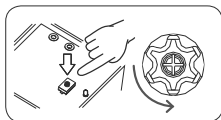

max 2 Sek

Durch Umhängen des BRAUNEN und SCHWARZEN Kabels des Motors auf den Klemmen des Funkempfängers, wird ebenfalls eine Änderung der Drehrichtung hervorgerufen.

**Die Drehrichtung bleibt auch nach einer kompletten Löschung der Programmierungen erhalten.**

# EINSTELLUNG ZUSÄTZLICHER HANDSENDER

Es können bis zu 15 Handsender gespeichert werden, sowohl auch den Sonnen- und Windsensor.

Tn: Eingestellter Handsender

Tx: Zusätzliche Handsender

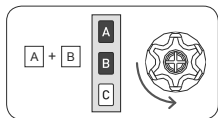

Tn

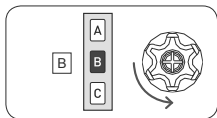

Tn

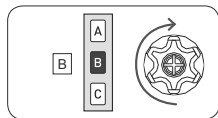

Tx (2 Sek)

# LÖSCHEN EINES EINZELNEN HANDSENDERS

Jeder gespeicherte Handsender kann einzeln gelöscht werden. Ist der letzte Handsender gelöscht kehrt der Funkempfänger in den anfänglichen Zustand zurück. Beim Mehrkanal-Handsender, vor dem Löschvorgang einfach den Kanal den man löschen möchte auswählen.

Tn: Zu löschender Handsender

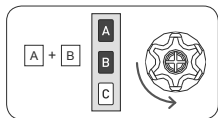

Tn

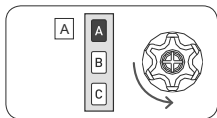

Tn

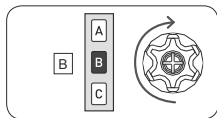

Tn (2 Sek)

# LÖSCHEN ALLER GESPEICHERTEN EINSTELLUNGEN

Die Löschung aller gespeicherten Einstellungen kann in zwei verschiedenen Art und Weisen getätigt werden:

## 1) MIT DEM HANDSENDER

Tn: Eingestellter Handsender

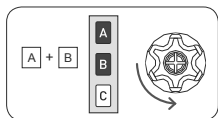

Tn

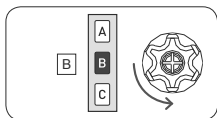

Tn

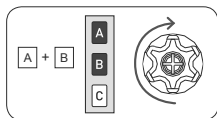

Tn (4 Sek)

## 2) MIT DER SET TASTE

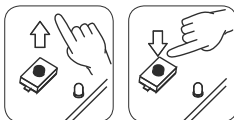
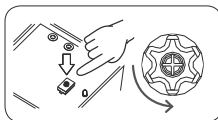

ca. 8 Sek

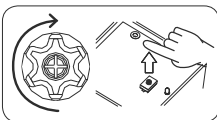

# BETÄTIGUNG ÜBER HANDSENDER

- Drehung nach UP steuert die Aufwärtsbewegung;
- Die Taste B unterbricht den Befehl;
- Drehung nach DOWN steuert die Abwärtsbewegung.

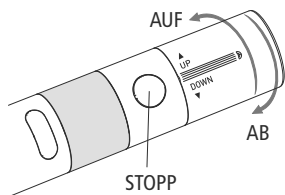

# OPTIONALER TASTERANSCHLUSS

Zusätzlich zum Handsender kann der Motor auch über einen verdrahteten Schalter oder Taster gesteuert werden (weißer Draht).

Der Funkempfänger kann programmiert werden, um mit Schaltern und Tasten in den Modi „Bediener anwesend“ (DM) oder „Bediener abwesend“ (MC) bedient zu werden.

## MODUS DM - BEDIENER ANWESEND

Die Auf- und Ab- Befehle bleiben aktiv, solange der Kontakt geschlossen bleibt und der Time-out Wert von 3 Minuten bleibt bestehend. Um den Motor anzuhalten, den Schalter auf die „Stopp“ Position stellen.

## MODUS MC - BEDIENER ABWESEND

Es genügt ein kurzer Auf- oder Ab-Impuls, um die Ausgänge mit einem fixen Time-out von drei Minuten zu aktivieren. Um den Motor anzuhalten, drücken Sie erneut Auf oder Ab.

## ÄNDERUNG DES MODUS VON DM ZU MC UND UMGEKEHRT

Der Funkempfänger ist werkseitig für den Modus DM eingestellt. Um zwischen den Modi DM und MC umzuschalten, gehen Sie folgendermaßen vor:

- 1) Trennen Sie den Funkempfänger vom Stromnetz und warten Sie 5 Sekunden.
- 2) Verbinden Sie den Funkempfänger wieder ans Stromnetz.
- 3) Warten Sie, bis die Led den aktuellen Modus anzeigt:
  - 1 Impuls für Modus DM.
  - 2 Impulse für Modus MC.
- 4) Drücken Sie innerhalb von vier Sekunden die SET Taste: Die Led zeigt bei entsprechender Anzahl der Impulse erneut den Modus an.

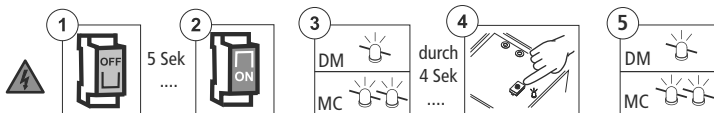

MODUSÄNDERUNG		
	DM	MC
 TASTE (Schritt-Schritt)	NO	✓
 SHALTER (Auf/Ab)	✓	✓

Sollte ein Schalter verbunden wird, stellt sich der Funkempfänger automatisch zur Verwendung der Auf-/Ab-Steuerungen ein.

Wenn Sie einen Taster wieder im Schrittsteuerungsmodus verwenden möchten, führen Sie die folgende Sequenz aus.

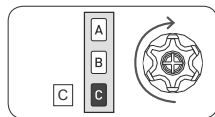
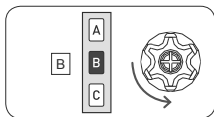
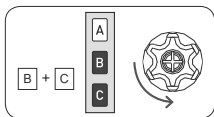

2 Sek

## TASTERANSCHLUSS MIT AUF-/AB-SCHALTER

Schließen Sie den Schalter am Eingang des Tasteranschlusses (weißer Draht) und die beiden Schalterklemmen an Phase und den Neutraleiter der Stromversorgung an.

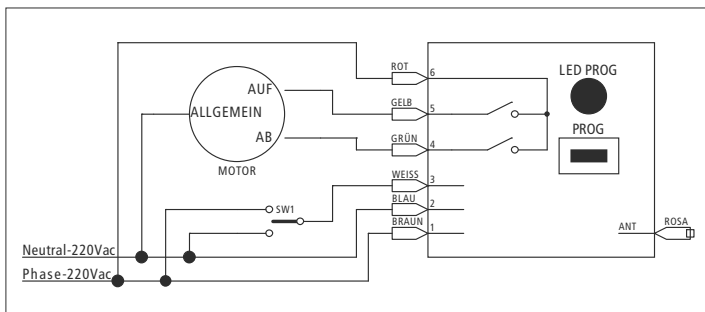

Bedienung per Funk oder verdrahteten Taster

## TASTERANSCHLUSS MIT INSTABLEM TASTER

In dieser Konfiguration ist es nicht möglich den DM Modus zu verwenden. Stellen Sie die Steuereinheit in den Modus „Bediener abwesend“ (MC) und verbinden Sie den Taster Taste an Phase und Eingang des optionalen Tasters (weißer Draht).

Mit jedem Drücken des Tasters erfolgt die Schrittsteuerung: Auf-Stopp-Ab-Stopp.

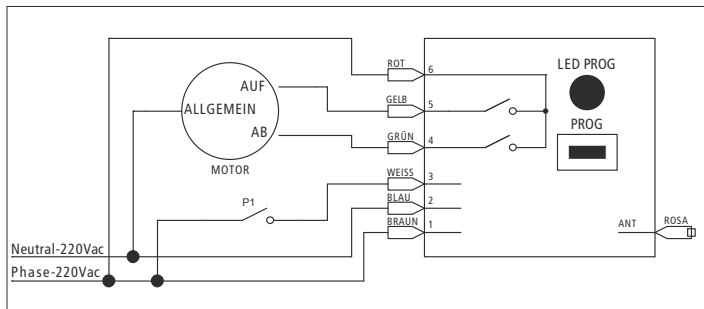

Schalter- und Funksteuerung des Motors Schrittsteuerung

## FUNKTION MIT WINDWÄCHTER-SONNENSENSOR

Die Wetterstationen TM2 X SW werden wie ein zusätzlicher Handsender auf den Funkempfänger einprogrammiert. Entsprechend den Wetterverhältnissen, bei Windstärke und Sonnenlicht, werden folgende automatische Funktionen ausgeführt:

Situation	Automatische Funktion
Sonnenaufgang (Licht über Niveau)	Drei Minuten nach Sonnenaufgang öffnet sich die Markise vollständig.
Sonnenuntergang (Licht unter Niveau)	Zehn Minuten nach Sonnenuntergang schließt sich die Markise vollständig.
Windalarm (Windstärke über Niveau)	Nach zwei Sekunden schließt sich die Markise vollständig, und bis zu acht Minuten, nachdem der Wind wieder unterhalb des Grenzwertes liegt, ist es nicht möglich, sie zu betätigen. Die rote Led blinkt.

## KOMPATIBLE GERÄTE

### WETTERSTATION TM2 X W

Misst die windbedingten Schwankungen am Ausfallprofil.

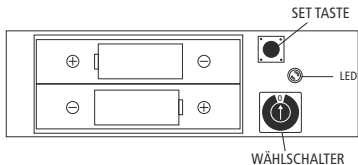
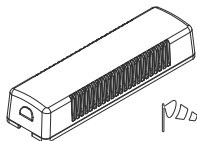

### EINPROGRAMMIERUNG DER WETTERSTATION

Um die Wetterstation mit dem Funkempfänger in Verbindung zu bringen, muss ein bereits eingestellter Handsender benutzt werden. Stellen Sie den Wählschalter auf die Position 0 und führen anschließend folgende Sequenz durch:

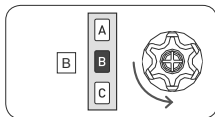
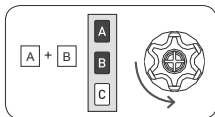

2 Sek

### LÖSCHEN DER WETTERSTATION

Zur Löschung der Verbindung der Wetterstation zum Funkempfänger, muss ein bereits eingestellter Handsender benutzt werden. Stellen Sie den Wählschalter auf die Position 0. Wenn der Sensor eingeschaltet ist, warten Sie, bis er sich ausschaltet, und führen anschließend folgende Sequenz durch:

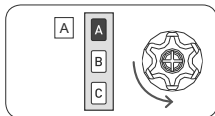
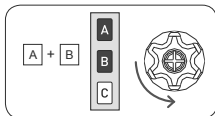

2 Sek

Eine vollständige Beschreibung der Funktionen dieses Geräts entnehmen Sie bitte dem in der Verpackung enthaltenen Benutzerhandbuches.



# WINDWÄCHTER

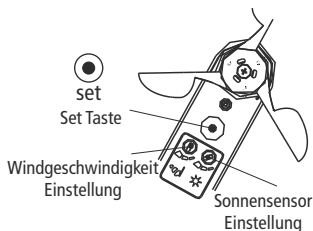
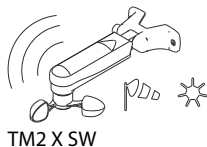

## EINPROGRAMMIERUNG

Um die Wetterstation mit dem Funkempfänger in Verbindung zu bringen, muss ein bereits eingestellter Handsender benutzt werden. Zur Einstellung geht man wie folgt vor:

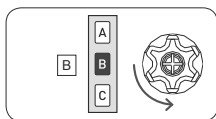
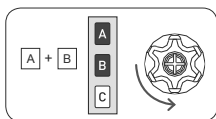

2 Sek

## LÖSCHEN

Zur Löschung der Verbindung der Wetterstation zum Funkempfänger, muss ein bereits eingestellter Handsender benutzt werden. Zur Löschung geht man wie folgt vor:

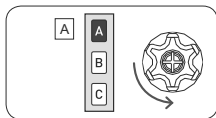
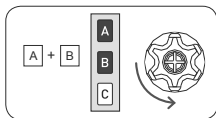

2 Sek

Eine vollständige Beschreibung der Funktionen dieser Geräte entnehmen Sie bitte dem in der Verpackung enthaltenen Benutzerhandbuchs.

## AKTIVIEREN / DEAKTIVIEREN DES SONNENSENSORS

(TM2 X SW)

Um das Aktivieren (automatische Schließung der Markise) oder Deaktivieren (manuelle Schließung d.M.) des Sonnensensors einzustellen, bitte die Einstellanleitungen bei der Wetterstation oder bei dem Handsender folgen.

### TEST MODUS FÜR TM2 X SW

Diese Funktion hat den Zweck die korrekte Funkverbindung zu überprüfen und die Windwächter und Sonnensensor Funktion zu testen.

Um die TEST Funktion zu aktivieren, die SET Taste für ca. 2 Sekunden drücken, bis die Markise von selbst eine ca. 10 Sekunden lange Ab-Bewegung durchführt und mit einer kurzen Auf-Bewegung den TEST Modus bestätigt. Der TEST Modus bleibt für ca. 3 Minuten aktiv. Man hat somit 3 Minuten Zeit die Wind- und Lichtwerte einzustellen und zu überprüfen. Nach 3 Minuten kehrt die Wetterstation automatisch zur normalen Anwendung zurück. Während des Tests leuchtet die rote LED im Innern des Funkempfängers.

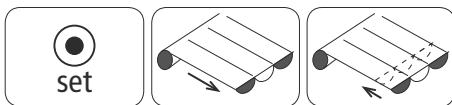

2 Sek

### WINDWÄCHTER FUNKTIONSTEST

Zur Fehlervermeidung während dem "Windwächter" Test, ist es ratsam den Sonnensensor zu deaktivieren. Wird nun das "Windrad" von Hand angetrieben, und wird dabei das "Alarmniveau" übertroffen, schließt Motor die Markise komplett.

### SONNENSENSOR FUNKTIONSTEST

Sicherstellen dass der Sonnensensor, automatischer Modus, aktiviert ist. Sobald der Lichtsensor eine Änderung der Lichtverhältnisse wahrnimmt, und dabei diese höher liegen als das voreingestellte Niveau, öffnet sich die Markise; oder schließt wenn die Lichtverhältnisse sich unterhalb der voreingestellten Niveaus begeben. Dieser Test kann mehrmals durchgeführt werden bis man die individuell idealen Schließ- und Öffnungs- Niveaus erörtert hat.

## KURZZEITIGE EINLERNUNG DES HANDSENDERS

Diese Funktion ermöglicht, einen Handsender vorübergehend zu speichern. Dies ist zum Beispiel erforderlich, wenn man die Einstellung der Endlagen während der Montage in der Fabrik durchführen will. Der Handsender kann danach unter Berücksichtigung der dafür vorgesehenen Befehlsreihenfolge endgültig gespeichert werden (siehe: "EINSTELLUNG DES ERSTEN HANDSENDERS"). Die nachstehend beschriebenen Arbeitsgänge dürfen ausschließlich beim neuen Funkempfänger oder nach vollständiger Löschung des Speichers (siehe: "LÖSCHEN ALLER GESPEICHERTEN EINSTELLUNGEN") durchgeführt werden. Um sicherzustellen, dass die vorübergehende Programmierung ausschließlich in der Installations- bzw. Einstellphase und nicht während des täglichen Gebrauchs benutzt wird, ermöglicht der Funkempfänger folgende Arbeitsgänge nur innerhalb der beschriebenen Zeitgrenzen. Den Funkempfänger mit Strom versorgen und sich vergewissern, dass keine anderen Funkempfänger im Aktionsraum des Handsenders mit Strom versorgt sind.

Die Taste B und die Taste C innerhalb von 30 Sekunden seit dem Starten gleichzeitig drücken, bis der Motor ein Bestätigungssignal ausgibt.

Der Handsender wird automatisch nach 5 Minuten gelöscht oder wenn der Funkempfänger vom Netz getrennt wird.

T1: Erster, einzustellender Handsender

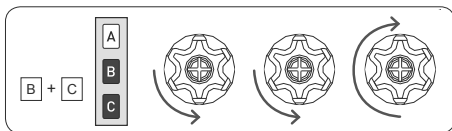

T1

## EU-KONFORMITÄTSERKLÄRUNG

Der Hersteller FAAC S.p.A. Soc. Unipersonale erklärt hiermit, dass die FAAC Funkanlage des Typs TM2 X R MINI der Richtlinie 2014/53/EU, 2011/65/EU entspricht.

Der vollständige Text der EU-Konformitätserklärung ist unter der folgenden Internetadresse verfügbar: <http://www.faac.biz/certificates>.

Bologna, 17-09-2018

CEO A. Marcellan



# SOMMAIRE

CONSIGNES DE SÉCURITÉ .....	54
CONNEXIONS ÉLECTRIQUES .....	54
LÉGENDE DES SYMBOLES .....	55
CARACTÉRISTIQUES TECHNIQUES .....	55
EXPLICATION DES SÉQUENCES DE COMMANDE .....	56
FONCTION D'OUVERTURE/FERMETURE DE LA PROGRAMMATION ÉMETTEUR LIGNE TM2 X T .....	57
MÉMORISATION DU PREMIER ÉMETTEUR .....	58
RÉGLAGE DU SENS DE ROTATION DU MOTEUR .....	58
MÉMORISATION D'AUTRES ÉMETTEURS .....	59
ANNULATION D'UN SEUL ÉMETTEUR .....	60
ANNULATION TOTALE DE LA MÉMOIRE DES ÉMETTEURS .....	60
ACTIONNEMENT A PARTIR DES ÉMETTEURS .....	61
COMMANDE FILAIRE EN OPTION .....	62
FONCTIONNEMENT AVEC ANÉMOMÈTRE AVEC CAPTEUR SOLEIL .....	64
TM2 X W .....	65
ANÉMOMÈTRES .....	66
MÉMORISATION TEMPORAIRE DE L'ÉMETTEUR .....	68
DÉCLARATION DE CONFORMITÉ UE .....	69

# CONSIGNES DE SÉCURITÉ

- L'installation doit être réalisée par un technicien compétent et dans le respect rigoureux des consignes de sécurité, surtout en ce qui concerne les connexions électriques.
- En amont du récepteur, prévoir un interrupteur bipolaire automatique pour la protection contre les courts-circuits avec une distance d'ouverture des contacts d'au moins 3 mm.
- Si le fil blanc n'est pas utilisé il doit toujours être isolé. Il est dangereux de toucher le fil blanc quand le moteur est connecté à l'électricité.

FR

## CONNEXIONS ÉLECTRIQUES

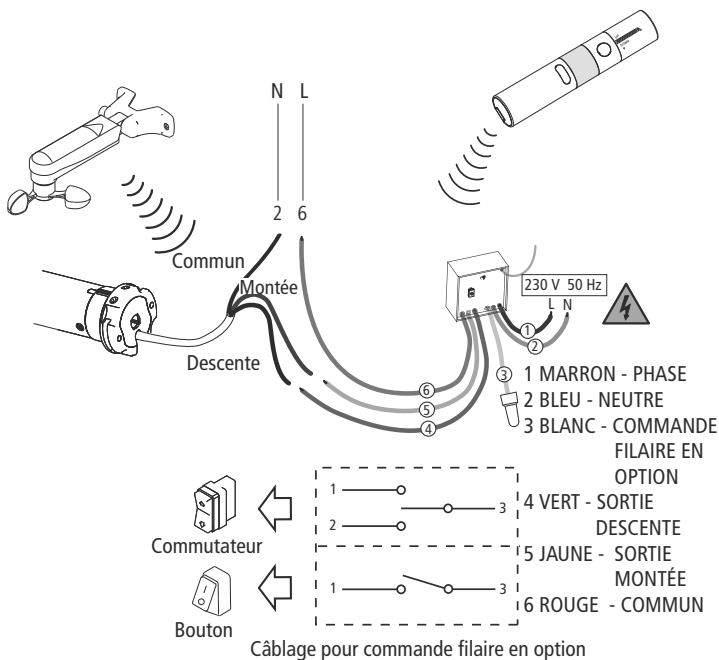

# LÉGENDE DES SYMBOLES

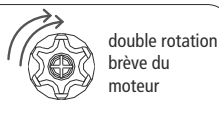
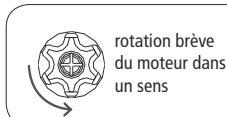
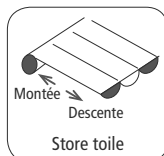
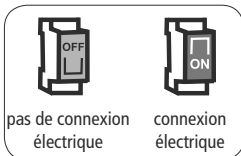
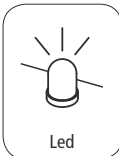
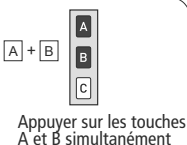
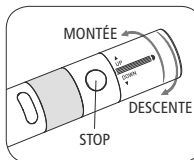
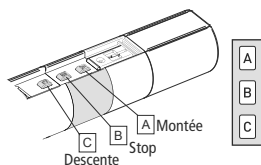

## CARACTÉRISTIQUES TECHNIQUES

- Alimentation	230 V / 50 Hz
- Puissance absorbée	0,5 W
- Fréquence radio	433,92 MHz
- Codification	Rolling Code
- Modulation	AM/ASK
- Nombre maxi. d'émetteurs	15
- Puissance maxi. du moteur	300 W
- Température de fonctionnement	-10 C° +55 C°
- Dimensions	40x40x20 mm
- Poids	80 gr
- Indice de protection	IP44

# EXPLICATION DES SÉQUENCES DE COMMANDE

Les séquences se composent pour la plupart de trois étapes bien distinctes à l'issue desquelles le moteur indique par différents types de rotation si l'étape s'est achevée de façon positive ou négative. Cette section a pour objet d'expliquer les signalisations du moteur.

Les touches doivent être enfoncées comme le montre la séquence, sans laisser s'écouler plus de 4 secondes entre une étape et l'autre. Si le temps qui s'écoule dépasse les 4 secondes, la commande n'est pas acceptée et il faudra répéter la séquence.

Exemple de séquence de commande:

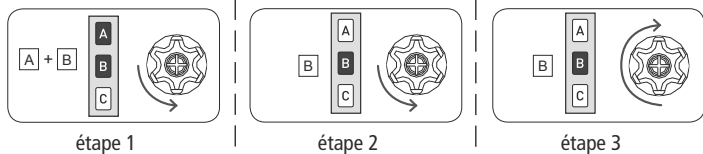

Comme le montre l'exemple, le moteur retourne à la position initiale par une seule rotation longue quand la séquence s'achève avec une issue positive. De fait, deux rotations brèves dans le même sens correspondent à une rotation longue dans le sens opposé. Le moteur retourne à la position initiale même si la séquence ne s'est pas achevée, en accomplissant dans ce cas une ou deux rotations brèves.

Exemples de séquences incomplètes:

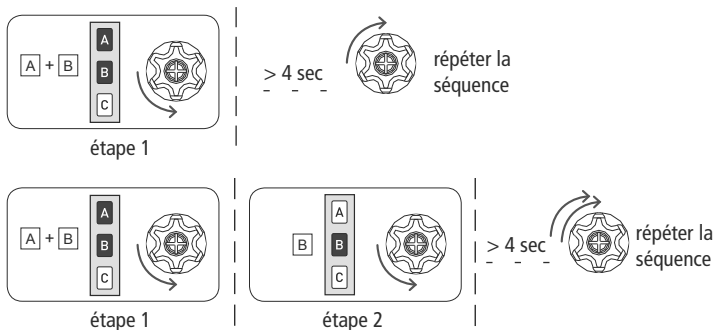



# FONCTION D'OUVERTURE/FERMETURE DE LA PROGRAMMATION ÉMETTEUR LIGNE TM2 X T

Pour éviter les modifications accidentelles sur la programmation du moteur pendant l'utilisation quotidienne de l'émetteur, la possibilité de programmation est automatiquement désactivée 8 heures après l'envoi de la dernière séquence (A+B ou B+C).

## VÉRIFICATION DE L'ÉTAT DE LA FONCTION

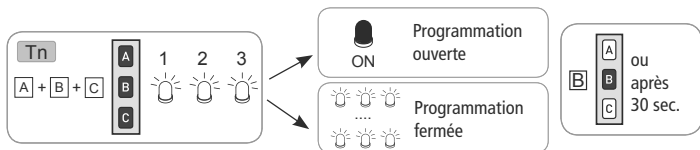

Pour modifier l'état de la fonction voir les séquences activation/désactivation

## ACTIVATION DE LA PROGRAMMATION

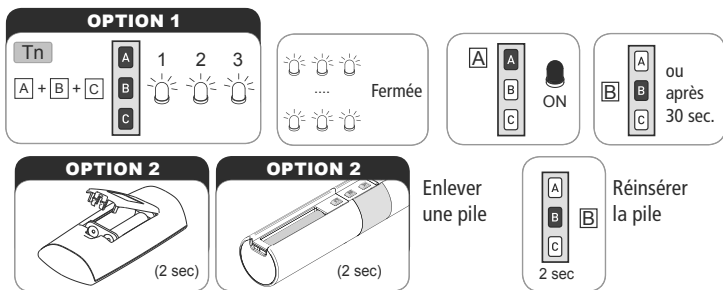

Procéder avec la programmation selon le manuel d'instructions

## DÉSACTIVATION DE LA PROGRAMMATION



# MÉMORISATION DU PREMIER ÉMETTEUR

Cette opération ne peut être accomplie que quand le récepteur est neuf ou après une annulation complète de la mémoire.

**Pendant cette phase, mettre un seul récepteur sous tension à la fois.**

T1: Premier émetteur à mémoriser

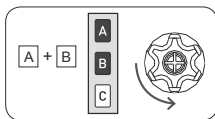

T1

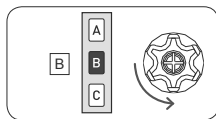

T1

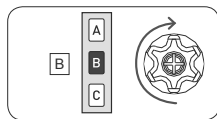

T1 (2 sec)

## DÉSACTIVATION AUTOMATIQUE DE LA MÉMORISATION DU PREMIER ÉMETTEUR

Chaque fois que le récepteur est activé vous avez 3 heures pour faire la mémorisation du premier émetteur. Après cette période la possibilité de mémorisation de l'émetteur est désactivée. Pour réinitialiser le timer de cette fonction on doit couper et rétablir l'alimentation du récepteur.

## RÉGLAGE DU SENS DE ROTATION DU MOTEUR

Accomplir cette opération quand la rotation du moteur n'est pas cohérente avec les touches de l'émetteur, par exemple si en activant la fonction montée (UP), le store ou le volet descend.

Il faut régler le sens correct de rotation si un anémomètre est associé au récepteur. En cas d'alarme de vent, le récepteur effectue toujours le mouvement qui correspond à la touche "montée".

Réglage du sens de rotation à l'aide de la touche SET:

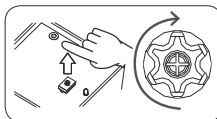
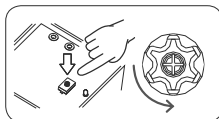

max 2 sec

Pour inverser le sens de rotation, il est aussi possible d'échanger les fils marron et noir sur le bornier du moteur.

**Le réglage du sens de rotation reste enregistré même après une annulation complète de la mémoire des émetteurs.**

# MÉMORISATION D'AUTRES ÉMETTEURS

Il est possible de mémoriser jusqu'à 15 émetteurs, y compris le capteur lumière/vent.

Tn: émetteur mémorisé

Tx: émetteur à mémoriser

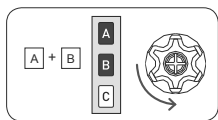

Tn

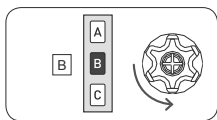

Tn

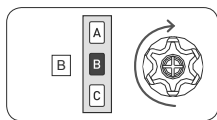

Tx (2 sec)

FR

# ANNULATION D'UN SEUL ÉMETTEUR

Il est possible d'annuler individuellement chaque émetteur mémorisé. Au moment où on annule le dernier, le récepteur retourne à sa position initiale. La même procédure s'applique à chaque canal de l'émetteur multicanaux: il suffit de sélectionner le canal à annuler avant d'accomplir la séquence.

Tn: émetteur à annuler

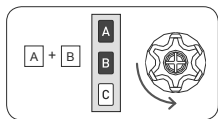

Tn

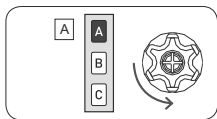

Tn

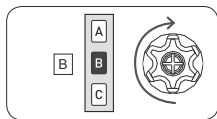

Tn (2 sec)

# ANNULATION TOTALE DE LA MÉMOIRE DES ÉMETTEURS

L'annulation totale de la mémoire peut s'effectuer de deux manières:

## 1) AVEC L'ÉMETTEUR

Tn: émetteur mémorisé

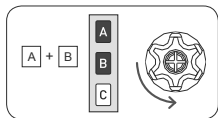

Tn

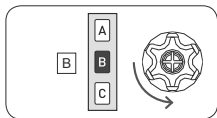

Tn

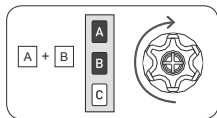

Tn (4 sec)

## 2) AVEC LA TOUCHE SET

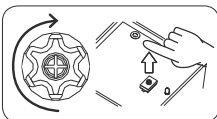
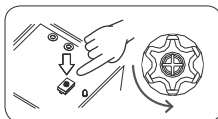

environ 8 sec

# ACTIONNEMENT A PARTIR DES ÉMETTEURS

- Rotation vers UP on commande la montée;
- La touche B interrompt la commande;
- Rotation vers DOWN on commande la descente.

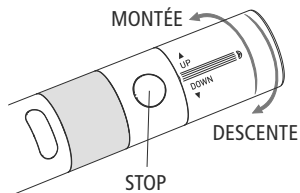

# COMMANDE FILAIRE EN OPTION

En plus de l'émetteur, il est possible de commander le démarrage et l'arrêt du moteur à l'aide d'un commutateur ou d'un bouton, relié par câble à l'entrée de la commande filaire en option (fil blanc).

Le récepteur peut être programmé pour fonctionner avec des commutateurs ou des boutons en modalité "homme présent" (DM) ou "mouvement continu" (MC).

## MODALITÉ DM - HOMME PRÉSENT

Les commandes de montée et de descente sont actives jusque le contact est fermé mais en respectant la temporisation de 3 minutes. Pour arrêter le moteur, placer le commutateur sur Stop.

## MODALITÉ MC - MOUVEMENT CONTINU

Une brève impulsion de montée ou de descente suffit à activer les sorties avec une temporisation fixe de 3 minutes. Pour arrêter le moteur, appuyer à nouveau sur montée ou descente.

## CHANGEMENT DE LA MODALITÉ DE DM À MC ET VICE VERSA

Le récepteur est configuré en usine pour la modalité DM. Pour passer de la modalité DM à la modalité MC, suivre les étapes suivantes:

- 1) Couper le courant et attendre 5 secondes.
- 2) Rebrancher le courant.
- 3) Attendre le clignotement de la Led indiquant la modalité actuelle:
  - 1 impulsion pour la modalité DM.
  - 2 impulsions pour la modalité MC.
- 4) Dans les 4 secondes suivantes, appuyer sur la touche SET: la Led confirme la nouvelle modalité par le nombre correspondant d'impulsions.

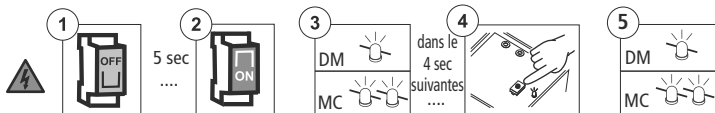

CHANGEMENT DE MODALITÉ		
	DM	MC
 BOUTON (pas-pas)	NO	✓
 COMMUTATEUR (montée/descent)	✓	✓

Si nous raccordons un commutateur, le récepteur se règle automatiquement pour l'utilisation des commandes montée/descente.

Si nous souhaitons utiliser à nouveau un bouton pour le mode séquentiel, transmettre la séquence suivante.

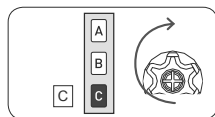
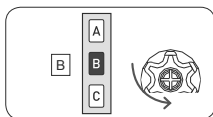
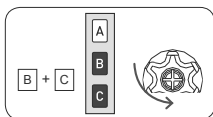

2 sec

FR

## COMMANDE FILAIRE AVEC COMMUTATEUR MONTÉE/DESCENTE

Raccorder le commun du commutateur à l'entrée de la commande filaire en option (fil blanc) et l'une des deux bornes de commutation à la Phase et l'autre au Neutre.

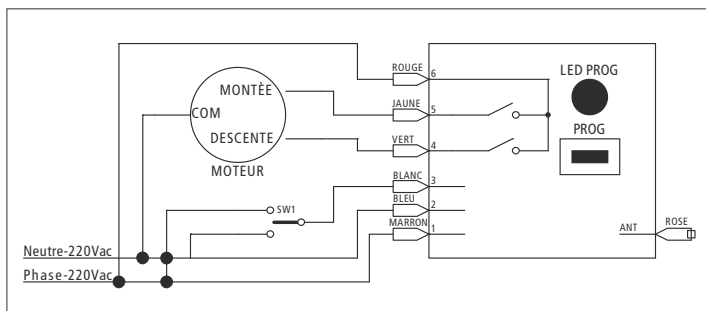

Commande du moteur radio + filaire depuis commutateur montée/descente

## COMMANDE FILAIRE AVEC BOUTON INSTABLE

Dans ce cas n'est pas possible utiliser la modalité DM.

Régler le récepteur sur la modalité mouvement continu (MC) et raccorder le bouton entre la Phase et l'entrée de la commande filaire en option (fil blanc).

Chaque pression du bouton entraîne le fonctionnement pas à pas: montée-stop-descente-stop.

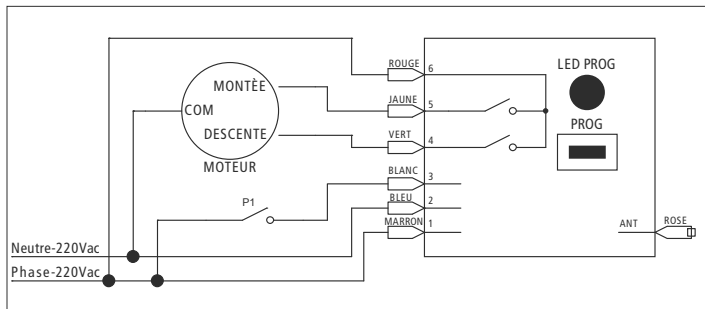

Commande du moteur radio + filaire depuis bouton pas/pas

## FONCTIONNEMENT AVEC ANÉMOMÈTRE AVEC CAPTEUR SOLEIL

Il est possible d'associer un anémomètre simple ou un anémomètre avec capteur soleil au récepteur radio. Lors des événements climatiques (apparition et disparition du soleil, alarme vent), le récepteur radio exécute les opérations suivantes:

Évènements	Automatismes
Apparition du soleil (luminosité dépassant le seuil)	Trois minutes après l'apparition du soleil le store s'ouvre complètement.
Disparition du soleil (luminosité inférieure au seuil)	Dix minutes après la disparition du soleil le store se ferme complètement.
Alarme vent (vent dépassant le seuil)	Après 2 secondes le store se ferme complètement et il n'est plus possible de l'actionner; il faudra attendre que 8 minutes se soient écoulées à partir du moment où la vitesse du vent sera redescendue en dessous du seuil. La Led rouge clignote.



## DISPOSITIF COMPATIBLES

### TM2 X W

Il détecte les oscillations provoquées par le vent sur la structure à bras.

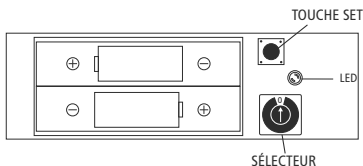
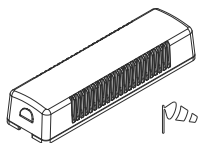

### MÉMORISATION DU CAPTEUR

Pour effectuer l'association du capteur au récepteur, il faut avoir déjà mémorisé un émetteur. Situer le sélecteur sur la position 0 puis exécuter la séquence suivante:

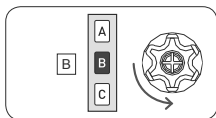
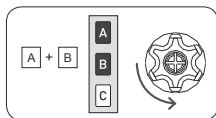

2 sec

### ANNULATION DU CAPTEUR

Pour annuler l'association du capteur au récepteur, il faut qu'il y ait un émetteur déjà mémorisé. Situer le sélecteur sur la position 0, s'il est activé attendre que le capteur s'éteigne, puis exécuter la séquence suivante:

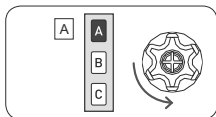
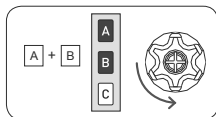

2 sec

Pour avoir la description complète des fonctions de ce dispositif, consulter le manuel d'instructions compris dans l'emballage.

# ANÉMOMÈTRES

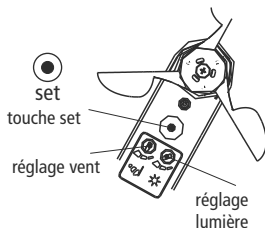

## MÉMORISATION

Pour effectuer l'association du capteur au récepteur, il faut avoir déjà mémorisé un émetteur. La séquence de mémorisation est la suivante:

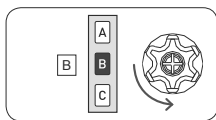
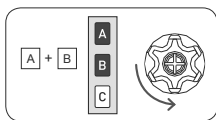

2 sec

## ANNULATION

Pour annuler l'association du capteur au récepteur, il faut qu'il y ait un émetteur déjà mémorisé. La séquence d'annulation est la suivante:

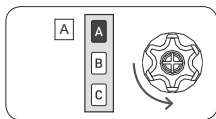
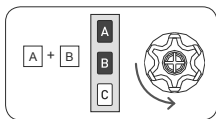

2 sec

Pour avoir la description complète des fonctions de ces dispositifs, consulter le manuel d'instructions compris dans l'emballage.

## ACTIVATION/DÉSACTIVATION DE LA FONCTION LUMIÈRE (TM2 X SW)

Pour activer (automatique) ou désactiver (manuel) la fonction lumière suivre les indications donnés sur les instructions de l'anémomètre ou de l'émetteur.

### TEST ANÉMOMÈTRE DU TYPE TM2 X SW

Cette fonction est utile pour vérifier la communication correcte par radio et pour essayer les fonctions vent et lumière.

Pour activer la fonction de TEST, maintenir la touche SET pressée (environ 2 sec) jusqu'à ce que le store s'ouvre pendant 10 secondes et indique par une fermeture de courte durée que le test est actif. La fonction de test reste active 3 minutes pendant lesquelles il est possible de vérifier la configuration des seuils de vent et lumière sans attendre les temps d'activation. Passé 3 minutes, le capteur TM2 X SW retourne à son fonctionnement normal. Pendant le test, la led rouge à l'intérieur du récepteur de marche reste allumée.

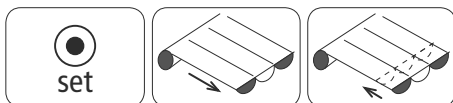

2 sec

#### ESSAI DE LA FONCTION VENT

Pour éviter les erreurs pendant l'essai de la fonction vent, il est recommandé de désactiver la fonction lumière. En faisant bouger les pales de l'anémomètre, le moteur déclenche la fermeture du store dès que la vitesse détectée par le capteur dépasse le seuil programmé.

#### ESSAI DE LA FONCTION LUMIÈRE

S'assurer que la fonction lumière est active. Quand le capteur détecte une variation de l'intensité de la lumière, il ouvre le store si l'intensité de la lumière s'élève au-dessus du seuil programmé, ou il le ferme si l'intensité de la lumière s'abaisse en dessous du seuil programmé. Il est possible de répéter ce test plusieurs fois pour régler au mieux le seuil souhaité.

## FONCTIONS SPÉCIALES

### MÉMORISATION TEMPORAIRE DE L'ÉMETTEUR

Cette fonction permet de mémoriser un émetteur de façon temporaire, par exemple pour permettre la mise au point des fins de course lors du montage à l'usine. L'émetteur définitif pourra être mémorisé par la suite à travers la séquence de commande correspondante (voir: "MÉMORISATION DU PREMIER ÉMETTEUR"). Les opérations décrites ci-dessous ne peuvent être réalisées que quand le récepteur radio est neuf d'usine ou après un effacement complet de la mémoire (voir: "ANNULATION TOTALE DE LA MÉMOIRE DES ÉMETTEURS"). Pour s'assurer que la programmation temporaire ne soit utilisée que lors des phases d'installation ou de mise au point et pas pendant l'utilisation quotidienne, le récepteur radio ne permet d'effectuer que les opérations ci-dessous et que dans les limites de temps indiquées. Mettre le récepteur radio sous tension; s'assurer qu'aucun autre récepteur radio sous tension et ayant la mémoire vide n'est présent dans le rayon d'action de l'émetteur.

**Dans les 30 secondes suivant l'allumage du dispositif**, appuyer simultanément sur les touches B et C jusqu'à ce que le moteur donne le signal de confirmation.

**L'émetteur restera mémorisé 5 minutes**, pendant que le récepteur radio est sous tension. Une fois les 5 minutes écoulées ou si le récepteur radio est mis hors tension, l'émetteur sera effacé.

T1: Premier émetteur à mémoriser

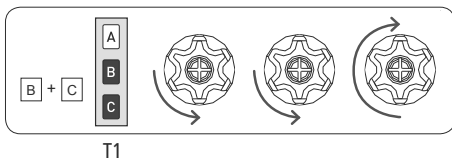

## DÉCLARATION DE CONFORMITÉ UE

Le fabricant, FAAC S.p.A. Soc. Unipersonale, déclare que le type d'équipement radio de la marque FAAC, modèle TM2 X R MINI est conforme à la directive 2014/53/EU, 2011/65/EU.

Le texte complet de la déclaration de conformité UE peut être lu à l'adresse Internet suivante: <http://www.faac.biz/certificates>

Bologna, 17-09-2018

CEO A. Marcellan



FR

# ÍNDICE

INSTRUCCIONES DE SEGURIDAD .....	71
CONEXIONES ELÉCTRICAS .....	71
LEYENDA DE SÍMBOLOS .....	72
CARACTERÍSTICAS TÉCNICAS .....	72
EXPLICACIÓN DE LAS SECUENCIAS DE MANDO .....	73
FUNCIÓN APERTURA/CIERRE PROGRAMACIÓN EMISOR SERIE TM2 X T .....	74
MEMORIZACIÓN DEL PRIMER EMISOR .....	75
CAMBIO DEL SENTIDO DE ROTACIÓN DEL MOTOR .....	75
MEMORIZACIÓN DE OTROS EMISORES .....	76
CANCELACIÓN DE UN EMISOR .....	77
CANCELACIÓN TOTAL DE LA MEMORIA .....	77
ACCIONAMIENTO POR EMISORES .....	78
MANEJO CABLEADO OPCIONAL .....	79
FUNCIONAMIENTO CON SENSOR SOL/VIENTO .....	81
SENSOR TM2 X W .....	82
ANEMÓMETROS .....	83
MEMORIZACIÓN TEMPORAL DE UN EMISOR .....	85
DECLARACIÓN DE CONFORMIDAD UE .....	86

# INSTRUCCIONES DE SEGURIDAD

- La instalación deber ser ejecutada por personal técnico con pleno respeto de las normas de seguridad, sobre todo en lo que concierne a las conexiones eléctricas.
- En la parte alta del circuito es necesario prever un seccionador bipolar con distancia de apertura de los contactos de al menos 3 mm.
- Si el cable blanco no es utilizado debe ser aislado siempre. Es peligroso tocar el cable blanco cuando el motor está conectado a corriente.

## CONEXIONES ELÉCTRICAS

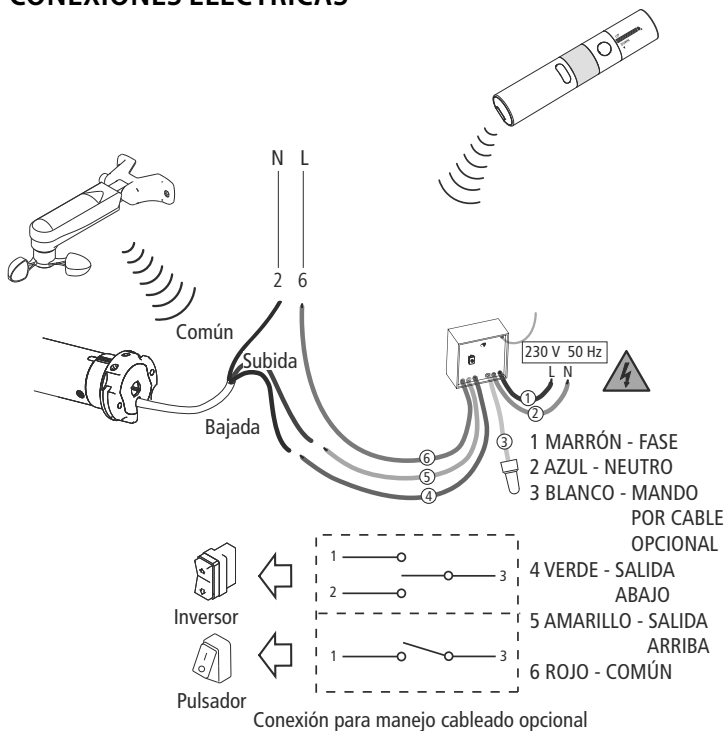

# LEYENDA DE SÍMBOLOS

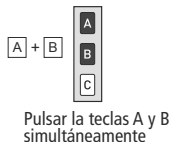
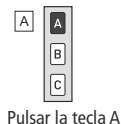
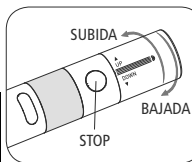
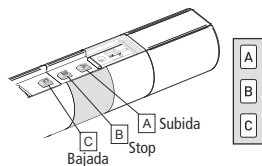

Quitar corriente



Conectar a corriente

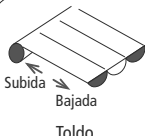

en los dos primeros pasos el motor realiza una breve rotación en un sentido.



en el tercer paso el motor realiza una rotación larga en sentido contrario a las dos anteriores.



si en el tercer paso el motor realiza una doble rotación en el mismo sentido, la codificación no se ha realizado correctamente. Habrá que volver a codificar la función que estábamos realizando.

## CARACTERÍSTICAS TÉCNICAS

- Alimentación	230 V / 50 Hz
- Potencia absorbida	0,5 W
- Frecuencia radio	433,92 MHz
- Codificación	Rolling Code
- Modulación	AM/ASK
- Núm. máx. emisores	15
- Potencia máx. motor	300 W
- Temperatura de funcionamiento	-10 C° +55 C°
- Dimensiones	40x40x20 mm
- Peso	80 gr
- Grado de protección	IP44



# EXPLICACIÓN DE LAS SECUENCIAS DE MANDO

La mayor parte de las secuencias de mando están compuestas por tres pasos bien diferenciados, al término de los mismos el motor realiza una señal, con diversos tipos de rotación, según el paso haya concluido en modo positivo o negativo.

El objetivo de este apartado es reconocer las indicaciones del motor.

Las teclas deben ser pulsadas tal y como se nos indica en la secuencia, sin que transcurran más de 4 segundos entre un paso y el otro. Si transcurren más de 4 segundos, la orden no será aceptada, y se deberá repetir la secuencia.

Ejemplo de secuencia de codificación:

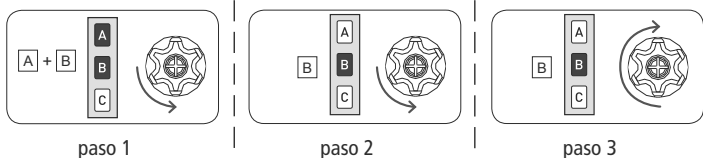

Como se ve en el ejemplo, cuando la secuencia termina de manera positiva el motor vuelve a la posición inicial mediante una rotación larga en sentido contrario a las dos anteriores. De hecho dos breves rotaciones en el mismo sentido corresponden con una rotación larga en el sentido opuesto.

El motor también vuelve a la posición inicial aunque la secuencia no haya sido correctamente completada, en este caso realizando una o dos breves rotaciones en sentido opuesto.

Ejemplos de secuencias incompletas:

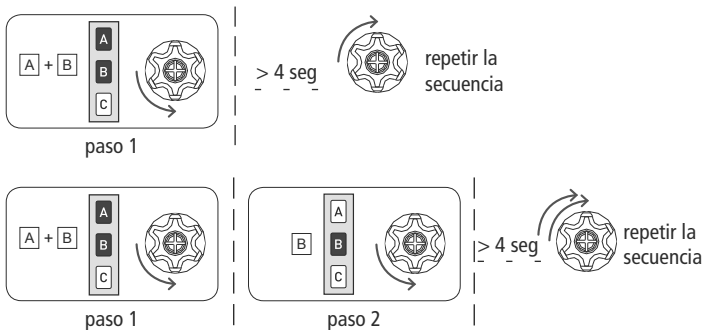

# FUNCIÓN APERTURA/CIERRE PROGRAMACIÓN EMISOR SERIE TM2 X T

Para evitar modificaciones accidentales en la programación del motor durante el uso cotidiano del emisor, la posibilidad de realizar programaciones será deshabilitada automáticamente transcurridas 8 horas el envío de la última secuencia.

## COMPROBACIÓN DEL ESTADO DE LA FUNCIÓN

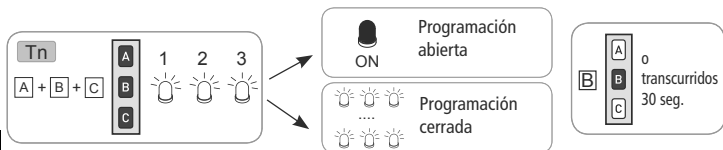

Para modificar el estado de la función ver las secuencias habilitar/deshabilitar

## HABILITAR LA PROGRAMACIÓN

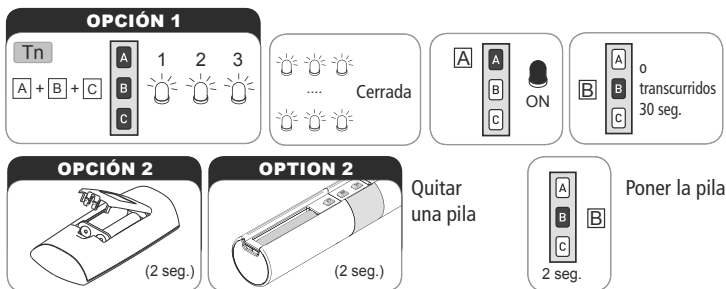

Proceder con la programación según el libro de instrucciones

## DESHABILITAR LA PROGRAMACIÓN



# MEMORIZACIÓN DEL PRIMER EMISOR

Esta operación se puede realizar solamente cuando la centralita es nueva o se ha realizado una cancelación total de la memoria de la centralita.

**Durante esta fase, para evitar interferencias, alimentar una sola centralita.**

T1: Primer emisor a memorizar

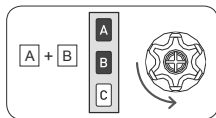

T1

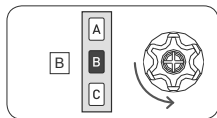

T1

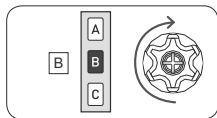

T1 (2 seg)

## FUNCIÓN DESHABILITACIÓN AUTOMÁTICA MEMORIZACIÓN PRIMER EMISOR

Cada vez que damos corriente a la centralita se dispone de tres horas para la memorización del primer emisor. Una vez transcurrido este tiempo, la posibilidad de memorizar el primer emisor queda deshabilitada. Para reestablecer nuevamente el tiempo de la función es suficiente quitar corriente y dar nuevamente corriente a la centralita.

## CAMBIO DEL SENTIDO DE ROTACIÓN DEL MOTOR

Realizar esta operación cuando la rotación del motor no coincida con las teclas del emisor, por ejemplo si activando subida (UP), el toldo o la persiana bajan.

Es necesario configurar el sentido de rotación correcto si la centralita tiene asociado un anemómetro. En caso de alarma por viento, la centralita realiza siempre un movimiento asociado al pulsador de subida.

Inversión del sentido de rotación utilizando el botón SET:

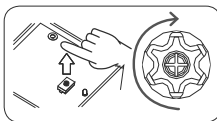
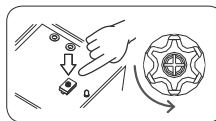

máx. 2 seg

El sentido de rotación puede ser invertido también, intercambiando los cables negro y marrón en las fichas de conexión del motor.

**El cambio del sentido de rotación se mantiene tras una cancelación total de la memoria.**

# MEMORIZACIÓN DE OTROS EMISORES

Es posible memorizar hasta 15 emisores incluido el sensor TM2 X SW.

Tn: Emisor memorizado

Tx: Emisor a memorizar

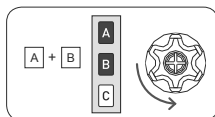

Tn

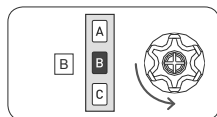

Tn

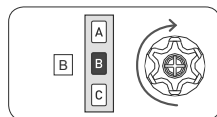

Tx (2 seg)

ES

# CANCELACIÓN DE UN EMISOR

Es posible cancelar individualmente cada emisor memorizado. En el momento en que se cancela el último la centralita queda en las condiciones iniciales. Lo mismo vale para los canales individuales del emisor multicanal, basta seleccionar el canal a cancelar antes de empezar la secuencia.

Tn: Emisor a cancelar

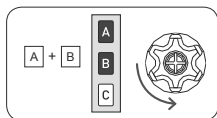

Tn

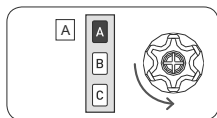

Tn

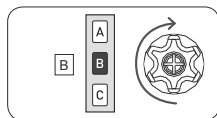

Tn (2 seg)

# CANCELACIÓN TOTAL DE LA MEMORIA

La cancelación total de la memoria se puede realizar de dos modos:

1) DESDE EL EMISOR

Tn: Emisor memorizado

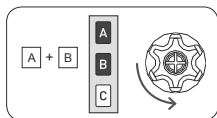

Tn

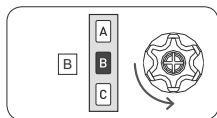

Tn

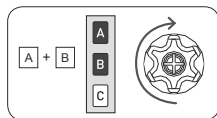

Tn (4 seg)

2) DESDE EL BOTÓN SET

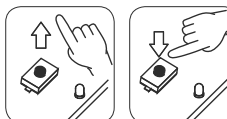
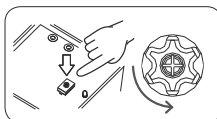

8 seg aprox

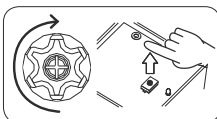

# ACCIONAMIENTO POR EMISORES

- Girando hacia UP se ordena la subida;
- La tecla B detiene la acción en curso;
- Girando hacia DOWN se ordena la bajada.

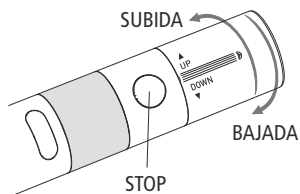

# MANEJO CABLEADO OPCIONAL

Además del emisor, se puede accionar el arranque y la parada del motor con un inversor o un pulsador conectado mediante cable a la entrada del manejo cableado opcional (cable blanco).

La centralita puede ser programada para funcionar con inversores y pulsadores en modo "hombre presente" (DM) o en "movimiento continuo" (MC).

## MODALIDAD DM - HOMBRE PRESENTE

Los mandos de subida y bajada permanecen activos mientras el contacto está cerrado, respetando en todos los casos, un tiempo de espera de 3 minutos. Para detener el motor, colocar el inversor en posición de Stop.

## MODALIDAD MC - MOVIMIENTO CONTINUO

Basta con un breve impulso de subida o bajada para activar las salidas con un tiempo de espera fijo de 3 minutos. Para detener el motor, pulsar nuevamente subida o bajada.

## CAMBIO DE MODALIDAD DE DM A MC Y VICEVERSA

La centralita viene configurada de fábrica en modalidad DM. Para pasar de la modalidad DM a la MC, realizar los siguientes pasos:

- 1) Interrumpir la alimentación y esperar 5 segundos.
- 2) Volver a conectar la alimentación.
- 3) Espera a que el led indique la modalidad actual:
  - 1 destello para la modalidad DM.
  - 2 destellos para la modalidad MC.
- 4) Durante los siguientes 4 segundos, pulsar el botón SET: el led indica la nueva modalidad y el respectivo número de destellos.

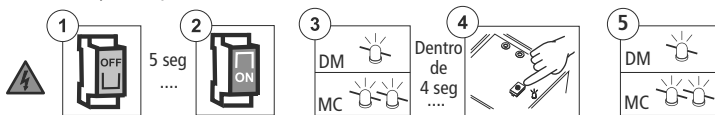

CAMBIO DE MODALIDAD		
	DM	MC
 PULSADOR (paso/paso)	NO	✓
 INVERSOR (arriba/abajo)	✓	✓





## MANEJO CABLEADO CON PULSADOR DE CONTACTO INESTABLE

En esta configuración no es posible utilizar la modalidad DM.

Configurar la centralita para la modalidad movimiento continuo (MC) y conectar el pulsador entre Fase y entrada del accionamiento cableado opcional (cable blanco). Cada vez que se presiona el pulsador, se obtiene la funcionalidad paso-paso: subida-stop-bajada-stop.

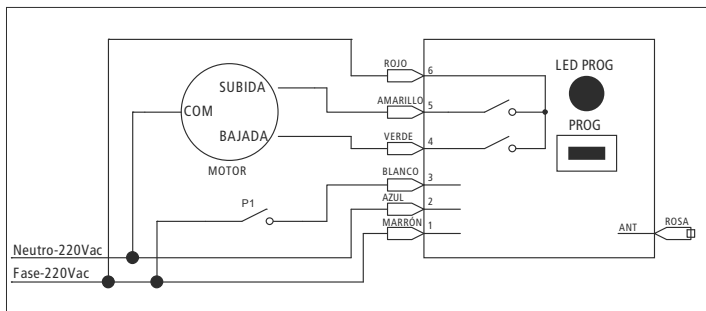

Mando motor radio + manejo cableado desde pulsador paso/paso

## FUNCIONAMIENTO CON SENSOR SOL/VIENTO

Puede asociarse un sensor de viento o sol/viento a la centralita. Frente a los eventos climáticos de aparición/desaparición del sol y en caso de alarma por viento, la centralita realiza las siguientes operaciones:

Evento	Automatismo
Aparición del sol (luz por encima del umbral)	Posterior a 3 minutos tras la aparición del sol, el toldo se abre completamente.
Desaparición del sol (luz por debajo del umbral)	Posterior a 10 minutos tras la desaparición del sol, el toldo se cierra completamente.
Alarma viento (viento por encima del umbral)	Tras 2 segundos, el toldo se cierra completamente y es imposible accionarlo hasta 8 minutos después de que la velocidad del viento haya vuelto al valor umbral. Parpadea el led rojo.

## DISPOSITIVOS COMPATIBLES

### SENSOR TM2 X W

Detecta las oscilaciones inducidas por el viento en la estructura de brazos.

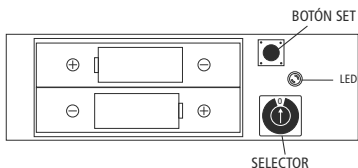
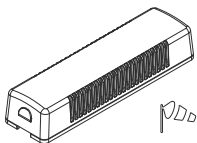

### MEMORIZACIÓN DEL SENSOR

Para realizar la asociación del sensor a la centralita, es necesario tener previamente un emisor memorizado. Poner el selector en la posición 0 y llevar a cabo la siguiente secuencia:

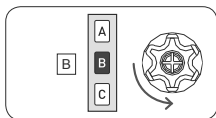
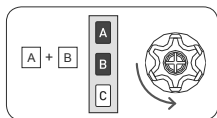

2 seg

### CANCELACIÓN DEL SENSOR

Para cancelar la asociación del sensor a la centralita es necesario un emisor ya memorizado. Poner el selector en la posición 0, esperar a que el sensor se apague (en caso de que esté activado) y llevar a cabo la siguiente secuencia:

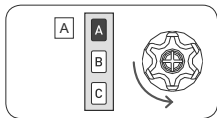
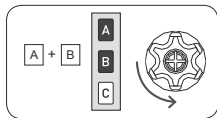

2 seg

Para la descripción completa de las funciones de este dispositivo, consultar el libro de instrucciones contenido en el embalaje.

# ANEMÓMETROS

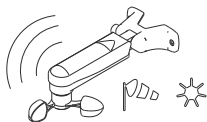

TM2 X SW

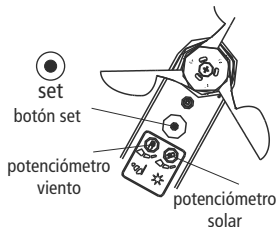

## MEMORIZACIÓN

Para realizar la asociación del sensor a la centralita, es necesario tener previamente un emisor memorizado. La secuencia de memorización es la siguiente:

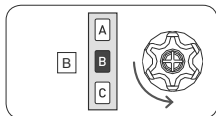
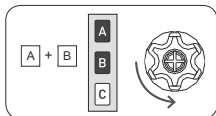

2 seg

## CANCELACIÓN

Para cancelar la asociación del sensor a la centralita es necesario un emisor ya memorizado. La secuencia de cancelación es la siguiente:

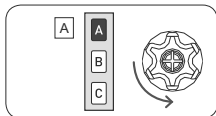
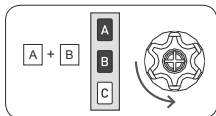

2 seg

Para la descripción completa de las funciones de estos dispositivos, consultar el libro de instrucciones contenido en el embalaje.

## ACTIVACIÓN / DESACTIVACIÓN DE LA FUNCIÓN LUZ (TM2 X SW)

Para activar (automático) o desactivar (manual) la función luz consulte el manual de instrucciones suministrado con el sensor o el emisor que va a utilizar.

### TEST PARA ANEMOMETRO TM2 X SW

Esta función es útil para verificar la correcta comunicación vía radio, y para efectuar la prueba de las funciones viento y sol.

Para activar la función TEST, mantener pulsada la tecla SET (2 seg aprox), hasta que el toldo se extienda durante 10 segundos y con un breve movimiento de cierre señale que el modo test este activo. La función de test permanecerá activa durante 3 minutos durante los cuales pueden comprobarse los valores de viento y sol establecidos sin necesidad de esperar los tiempos de activación. Después de 3 minutos, el sensor TM2 X SW vuelve a funcionar en modo normal. Durante el test el led interno de la centralita permanece encendido.

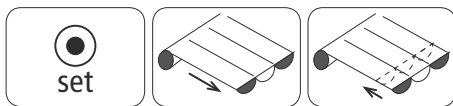

2 seg

#### PRUEBA DE LA FUNCIÓN VIENTO

Para evitar errores durante la prueba de la función viento, se recomienda desactivar la función sol. Moviendo las palas del anemómetro, cuando la velocidad notada por el sensor sea superior a la velocidad programada, el motor realiza la recogida del toldo.

#### PRUEBA DE LA FUNCIÓN SOL

Asegurarse que la función sol esté activada. Cuando el sensor nota una variación de la intensidad de la luz: abre el toldo si la intensidad de la luz está por encima del umbral programado, por el contrario recoge el toldo si la intensidad de la luz está por debajo del umbral programado. Es posible repetir el test para regular óptimamente el umbral deseado.

## FUNCIONES ESPECIALES

# MEMORIZACIÓN TEMPORAL DE UN EMISOR

Esta función permite memorizar un emisor de forma temporal, por ejemplo, para permitir la puesta a punto de los fines de carrera durante el montaje en fábrica. El emisor definitivo se podrá memorizar más adelante utilizando la secuencia de mando correspondiente (ver: "MEMORIZACIÓN DEL PRIMER EMISOR"). Las operaciones que se indican a continuación solamente se pueden llevar a cabo cuando la centralita es nueva de fábrica, o bien después de una cancelación total de la memoria (ver: "CANCELACIÓN TOTAL DE LA MEMORIA"). Para garantizar que la programación temporal solamente se utiliza en la fase de instalación o de puesta a punto y no durante el uso cotidiano, la centralita solamente permite realizar las operaciones siguientes dentro de los límites de tiempo descritos.

Alimentar la centralita, comprobar que en el radio de acción del emisor no están presentes otras centralitas alimentadas y/o con la memoria vacía.

**Dentro de los 30 segundos posteriores al encendido, pulsar simultáneamente las teclas B y C, hasta que el motor conectado realiza la señal de confirmación.**

**El emisor permanecerá memorizado 5 minutos, mientras la centralita esté alimentada.** Transcurridos 5 minutos o cuando se quite tensión a la centralita, el emisor se borrará.

T1: Primer emisor a memorizar

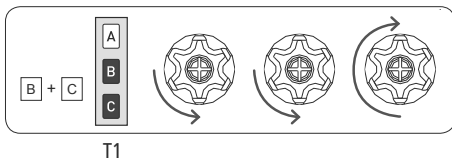

## DECLARACIÓN DE CONFORMIDAD UE

El fabricante, FAAC S.p.A. Soc. Unipersonale, declara que el tipo de equipo de radio marca FAAC modelo TM2 X R MINI cumple los requisitos de la directiva 2014/53/EU, 2011/65/EU.

El texto completo de la declaración de conformidad UE está disponible en la siguiente dirección de Internet: <http://www.faac.biz/certificates>

Bologna, 17-09-2018

CEO A. Marcellan



# OVERZICHT

VEILIGHEIDSVOORSCHRIFTEN .....	88
ELEKTRISCHE AANSLUITINGEN .....	88
LEGENDE VAN DE SYMBOLEN .....	89
TECHNISCHE KENMERKEN .....	89
UITLEG VAN DE BEDIENINGSREEKS .....	90
AFSTANDBEDIENING PROGRAMMEREN VOOR OPENING/SLUITING .....	91
MEMORISATIE EERSTE AFSTANDBEDIENING .....	92
DE DRAAIRICHTING VAN DE MOTOR AFSTELLEN .....	92
MEMORISATIE VAN ANDERE AFSTANDBEDIENINGEN .....	93
EEN ENKELE AFSTANDBEDIENING WISSEN .....	94
VOLLEDIGE UITWISSING VAN HET AB-GEHEUGEN .....	94
BESTURING MET AFSTANDBEDIENING .....	95
BEDIENINGSKABEL OPTIONEEL .....	96
WERKING MET LICHT/WIND SENSOR .....	98
SENSOR TM2 X W .....	99
WINDMETERS .....	100
TIJDELIJKE MEMORISATIE VAN DE AFSTANDBEDIENING .....	102
EU-CONFORMITEITSVERKLARING .....	103

# VEILIGHEIDSVOORSCHRIFTEN

- De installatie dient door technisch personeel te worden uitgevoerd in volledige naleving van de veiligheidsvoorschriften, vooral als het om elektrische aansluitingen gaat.
- Stroomopwaarts van de regeleenheid moet een bipolaire automatische schakelaar worden geplaatst ter bescherming tegen kortsluiting, met een contact openingsafstand van min 3 mm.
- Wanneer de witte draad niet gebruikt wordt, da dient deze altijd te worden geïsoleerd. Het is gevaarlijk om de witte draad aanraken wanneer de motor onder spanning staat.

# ELEKTRISCHE AANSLUITINGEN

NL

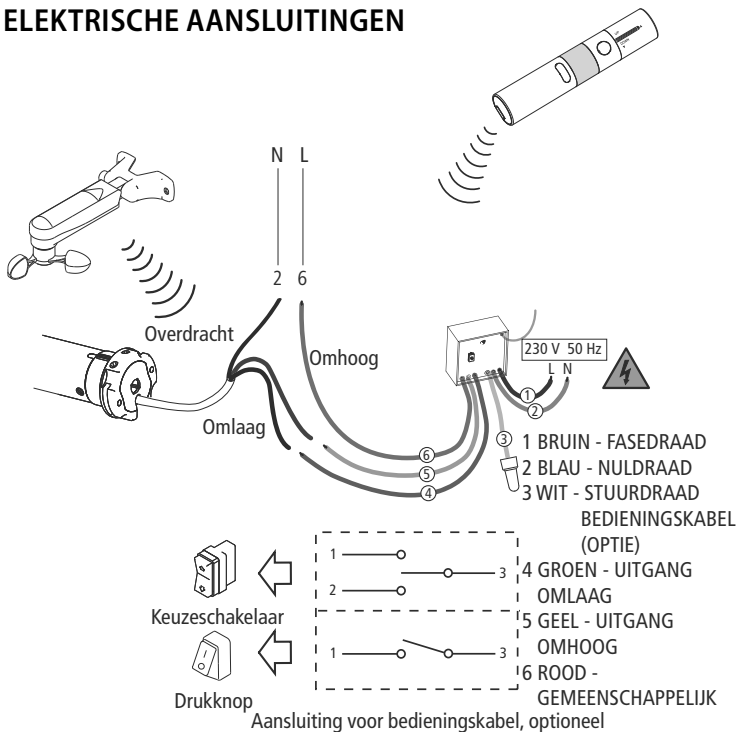



# LEGENDE VAN DE SYMBOLEN

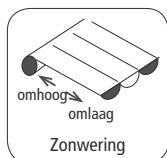
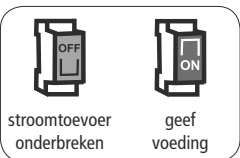
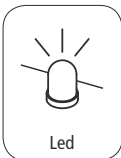
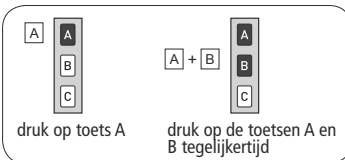
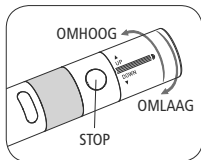
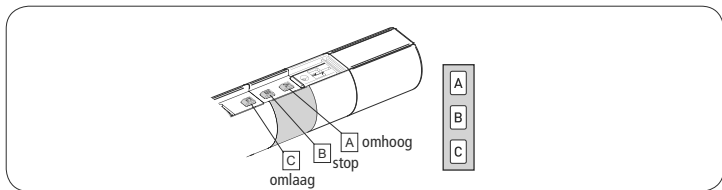

## TECHNISCHE KENMERKEN

- Voeding	230 V / 50 Hz
- Opgenomen vermogen	0.5 W
- Radiofrequentie	433.92 MHz
- Codering	Rolling Code
- Modulatie	AM/ASK
- Aantal max. zenders	15
- Opgenomen vermogen motor	300 W
- Bedrijfstemperatuur	-10 C° +55 C°
- Afmetingen	40x40x20 mm
- Gewicht	80 gr
- Beschermingsklasse	IP44

# UITLEG VAN DE BEDIENINGSREEKS

De meeste reeksen bedieningen bestaan uit drie verschillende stappen. Aan het einde hiervan, geeft de motor met verschillende soorten rotatie aan of de stap positief of negatief is afgerond. Het doel van dit paragraaf is om uitleg te geven om de signalen vanaf de motor te herkennen.

De toetsen dienen in de aangegeven volgorde te worden ingedrukt en zonder dat er meer dan 4 seconden tussen iedere stap wordt gelaten. Bij meer dan 4 seconden tussen de stappen, zal de opdracht niet uitgevoerd worden en moet de reeks herhaald worden.

Voorbeeld van bedieningsreeks:

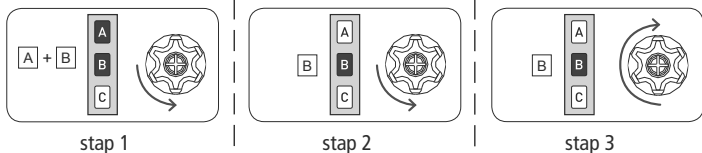

Het voorbeeld geeft aan dat wanneer de reeks positief is afgerond, de motor naar de startpositie terugkeert d.m.v. een enkele lange rotatie. In feite, twee korte rotaties in dezelfde richting gelden als een lange rotatie in de tegenovergestelde richting. De motor keert naar de startpositie terug ook wanneer de reeks niet is afgerond. In dit geval graait hij een of twee keer kort.

Voorbeelden van onvoltooide reeksen:

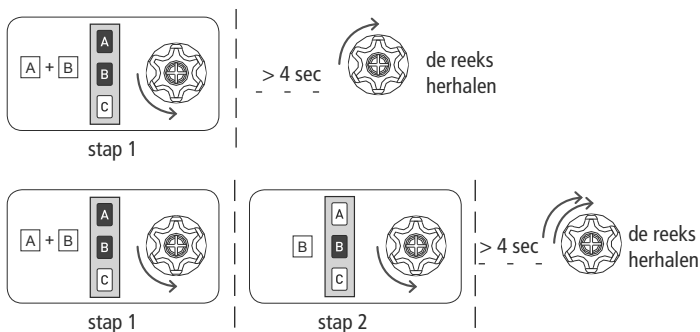

# AFSTANDSBEDIENING PROGRAMMEREN VOOR OPENING/SLUITING

Om ongewenste wijzigingen van de programmering van de motor tijdens dagelijks gebruik te voorkomen, wordt de programmering 8 uur na het verzenden van de laatste reeks (A+B of B+C) automatisch uitgeschakeld.

## CONTROLE VAN DE FUNCTIESTAND

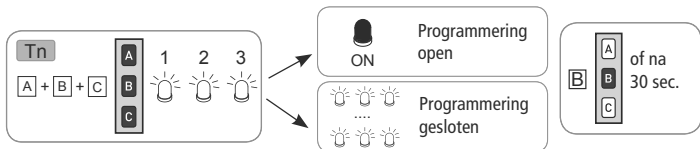

Om de functiestand te wijzigen, zie de reeksen activering/deactivering

## ACTIVERING VAN DE PROGRAMMERING

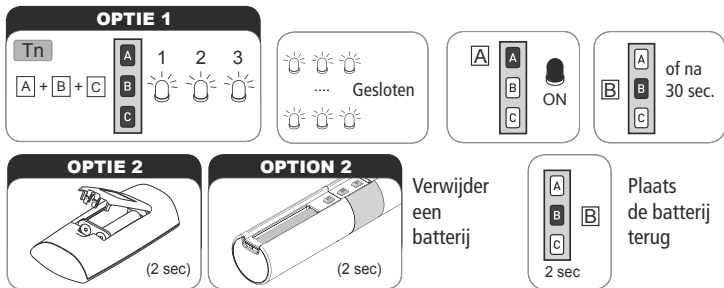

Ga door met de programmering volgens de handleiding

## DEACTIVERING VAN DE PROGRAMMERING



# MEMORISATIE EERSTE AFSTANDSBEDIENING

Deze handeling kan uitsluitend bij een nieuwe regeleenheid worden uitgevoerd; het geheugen wordt in dit geval anders volledig gewist.

**Gedurende deze procedure, één regeleenheid per keer voeden.**

T1: Memorisatie eerste afstandsbediening

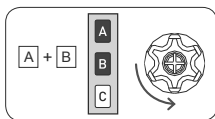

T1

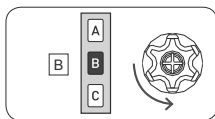

T1

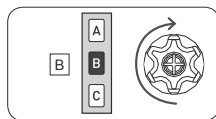

T1 (2 sec)

## AUTOMATISCHE UITSCHAKELFUNCTIE MEMORISATIE EERSTE AFSTANDSBEDIENING

Bij het aanzetten van de regeleenheid heeft u 3 uur de tijd om de eerste afstandsbediening te memoriseren. Nadat deze tijd is verstreken, is de functie voor de memorisatie van de afstandsbediening uitgeschakeld. Om de timer van de functie te resetten dient u de voeding naar de regeleenheid tijdelijk te onderbreken.

## DE DRAAIRICHTING VAN DE MOTOR AFSTELLEN

Voer deze procedure uit als de draairichting van de motor niet in overeenstemming is met de AB-toetsen, bijv. als de zonwering of rolluik zakt bij het indrukken van OMHOOG (UP).

Het is van groot belang de juiste draairichting in te stellen indien de regeleenheid van een windmeter is voorzien. Bij een windalarm is de regeleenheid ingesteld om de opdracht te geven die met de toets "OMHOOG" geassocieerd is.

De draairichting afstellen m.b.v. de SET toets:

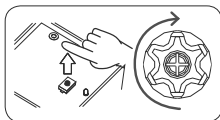
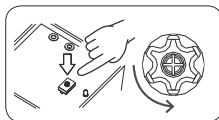

max 2 sec

De draairichting kan ook worden omgekeerd door de bruine en zwarte draden op het klemmenbord van de motor om te zetten.

**De ingestelde draairichting blijft behouden ook nadat het geheugen volledig is gewist.**

# MEMORISATIE VAN ANDERE AFSTANDBEDIENINGEN

Het is mogelijk om tot 15 afstandsbedieningen te memoriseren.

Tn: Gememoriseerde afstandsbediening

Tx: Te memoriseren afstandsbediening

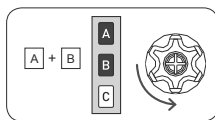

Tn

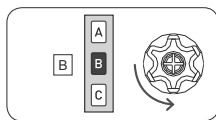

Tn

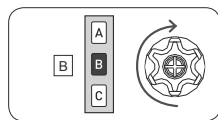

Tx (2 sec)

# EEN ENKELE AFSTANDBEDIENING WISSEN

Iedere gememoriseerde afstandsbediening kan individueel gewist worden. Bij het wissen van de laatste afstandsbediening gaat de regeleenheid naar de initiële stand terug. Hetzelfde geldt m.b.t. de individuele kanalen van de multichannel afstandsbediening; eerst het kanaal selecteren en vervolgens wissen.

Tn: Te wissen afstandsbediening

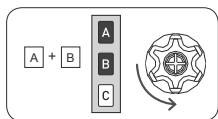

Tn

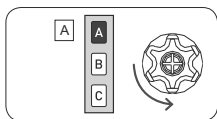

Tn

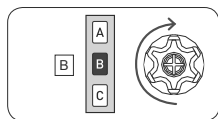

Tn (2 sec)

NL

## VOLLEDIGE UITWISSING VAN HET AB-GEHEUGEN

Het geheugen kan op twee manieren volledig gewist worden:

1) VIA DE AFSTANDBEDIENING

Tn: Gememoriseerde afstandsbediening

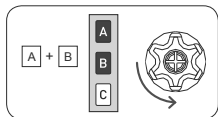

Tn

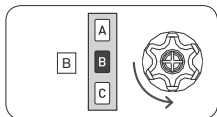

Tn

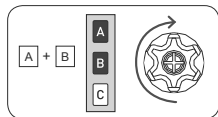

Tn (4 sec)

2) MET DE SET TOETS

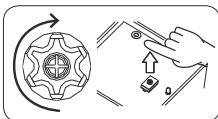
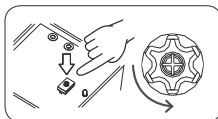

circa 8 sec

## BESTURING MET AFSTANDSBEDIENING

- Door naar UP te draaien wordt de opwaartse beweging bestuurd;
- De STOP toets onderbreekt de besturing;
- Door naar DOWN te draaien wordt de neerwaartse beweging bestuurd.

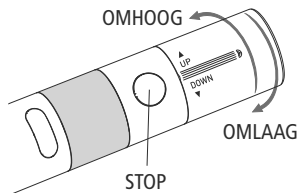

# BEDIENINGSKABEL OPTIONEEL

Naast met de afstandbediening, kan de motor ook via een bedieningskabel met keuzeschakelaar of drukknop worden bestuurd. Deze is aangesloten op de optionele ingang voor kabelbediening (witte draad).

De regeleenheid kan ook geprogrammeerd worden voor de toepassing van keuzeschakelaars of drukknoppen in "dodemansmodus" (DM) of in de modus voor "continue beweging" (MC).

## "Dodemansmodus" (DM)

De opwaartse en neerwaartse besturing blijft actief zolang het contact gesloten blijft; dit in ieder geval met een time-out van 3 minuten. Om de motor stil te leggen de keuze schakelaar op Stop zetten.

## Modus "Continue beweging" (MC)

een kleine puls omhoog of omlaag is voldoende om de uitgangen te activeren met een time-out van 3 minuten. Om de motor dan opnieuw stil te leggen, druk gewoon weer op omhoog of omlaag.

## MODUS WIJZIGEN VAN DM NAAR MC EN ANDERSOM

De regeleenheid is af fabriek vooraf ingesteld op DM. Om de modus te wijzigen van DM naar MC gaat u als volgt te werk:

- 1) Verbreek de stroomtoevoer en wacht 5 seconden.
- 2) Zet de stroom weer aan.
- 3) Wacht tot de LEDs aangeven welke modus nu aanstaat:
  - 1 x knipperen voor modus DM.
  - 2 x knipperen voor modus MC.
- 4) Binnen 4 seconden, druk op SET: de LED geeft nu de actuele modus aan d.m.v. het betreffende aantal keren knipperen.

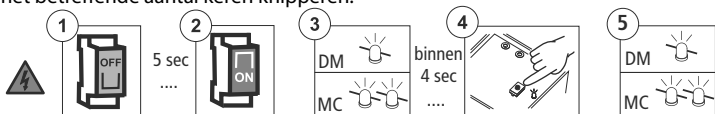

WIJZIG MODUS		
	DM	MC
DRUKKNOP (stapsgewijs)	NO	✓
KEUZESCHAKELAAR (OMHOOG/OMLAAG)	✓	✓



Wanneer een keuzeschakelaar wordt toegepast, zal de regeleenheid automatisch op omhoog/omlaag bediening zijn ingesteld.

Indien de keuzeschakelaar met een drukknop wordt vervangen, dan moet de bedrijfsmodus naar stapsgewijs worden gewijzigd d.m.v. de volgende reeks opdrachten.

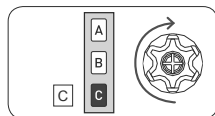
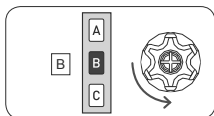
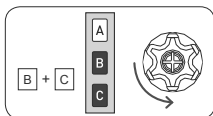

2 sec

## VOORBEELD VAN KABELBEDIENING MET KEUZESCHAKELAAR OMHOOG/OMLAAG

Sluit de rode draad van de keuzeschakelaar aan op de ingang van optionele bedieningskabel (witte draad) en de twee aansluitingen één op de fasedraad en één op de nuldraad.

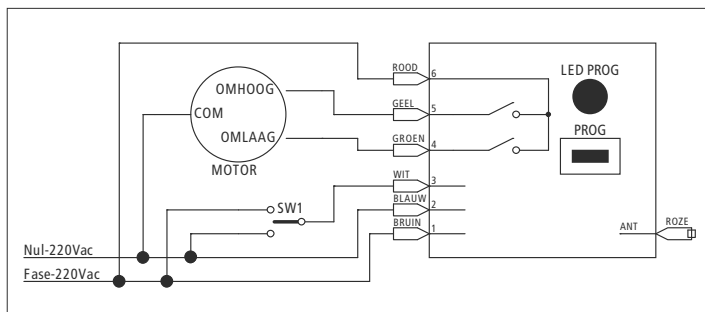

Motorbediening via radio + kabel met keuzeschakelaar omhoog/omlaag

## VOORBEELD VAN KABELBEDIENING MET DRUKKNOP

Bij deze configuratie is de modus "DM" niet toepasbaar.

De regeleenheid moet in de modus voor continue beweging (MC) en de drukknop moet worden aangesloten tussen fase draad en ingang van de optionele bedieningskabel (witte draad).

Bij het indrukken van de knop gaat de motor stapsgewijs werken: omhoog-stop-omlaag-stop.

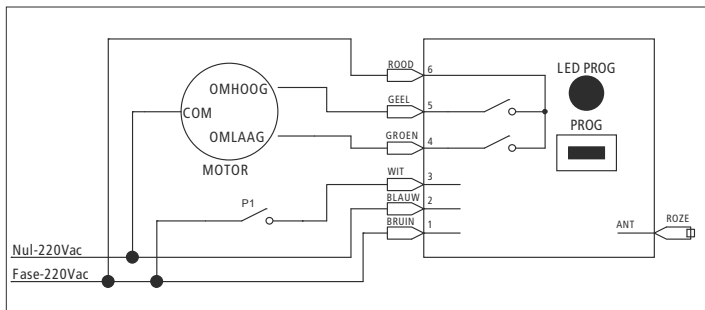

Motorbediening via radio + kabel met stapsgewijze drukknop

## WERKING MET LICHT/WIND SENSOR

Het is mogelijk om een licht/wind sensor op de regeleenheid aan te sluiten. Bij het veranderen van de weersomstandigheden, d.w.z. het meer/minder velworden van het zonlicht en/of bij een windalarm, gaat de regeleenheid als volgt te werk:

Gebeurtenis	Automatisme
Zon komt door (licht boven grenswaarde)	Na 3 minuten van het verschijnen van de zon, zal de zonwering volledig opengaan.
Zon gaat weg (licht beneden grenswaarde)	Na 10 minuten van het verdwijnen van de zon, zal de zonwering volledig dichtgaan.
Windalarm (wind boven grenswaarde)	Na 2 seconden dat de zonwering volledig dicht is gegaan, zal deze pas na 8 minuten nadat de wind beneden de grenswaarde is teruggezakt weer open kunnen. De rode LED knippert.

## COMPATIBILE APPARATEN

### SENSOR TM2 X W

Neemt de trillingen waar die door de wind op de armen worden veroorzaakt.

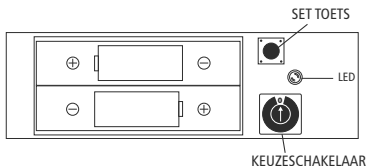
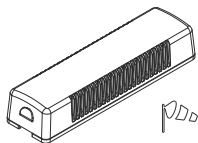

### MEMORISATIE SENSOR

Om de sensor aan de regeleenheid te koppelen moet eerst de afstandsbediening zijn ingesteld. Breng de keuzeschakelaar in de 0 stand en voer de volgende stappen uit:

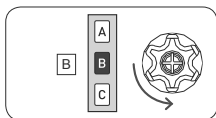
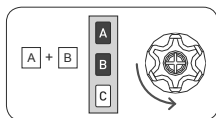

2 sec

### SENSOR WISSEN

Om de sensor van de regeleenheid los te koppelen moet eerst de afstandsbediening zijn ingesteld. Zet de keuzeschakelaar op 0. Als de sensor actief is, eerst even wachten totdat deze uit gaat en vervolgens de volgende stappen uitvoeren:

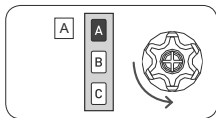
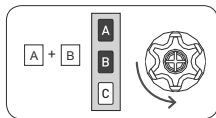

2 sec

Voor een uitgebreide beschrijving van de functies van het apparaat dient u de handleiding te raadplegen. Deze vindt u in de verpakking terug.

# WINDMETERS

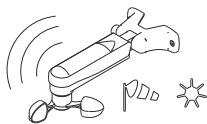

TM2 X SW

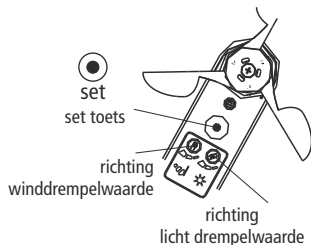

## MEMORISATIE

Om de sensor aan de regeleenheid te koppelen moet eerst de afstandsbediening zijn ingesteld. De volgorde voor het memoriseren is als volgt:

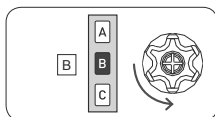
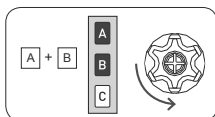

2 sec

## WISSEN

Om de sensor van de regeleenheid los te koppelen moet eerst de afstandsbediening zijn ingesteld. De volgorde voor het wissen is als volgt:

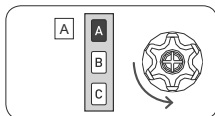
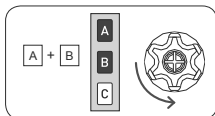

2 sec

Voor een uitgebreide beschrijving van de functies van deze inrichtingen dient u de betreffende handleiding te raadplegen. Deze vindt u in de verpakking terug.

## ACTIVERING/DEACTIVERING VAN DE LICHTFUNCTIE

(TM2 X SW)

Om de lichtfunctie te activeren (automatisch) of te deactiveren (handmatig) verwijzen wij u naar de handleiding die met de gebruikte sensor of afstandsbediening meegeleverd is.

### WINDMETER TEST VOOR TYPE TM2 X SW

Deze functie is bedoeld om de juiste radiocommunicatie te testen en om de wind- en lichtfuncties te controleren.

Om de licht-TEST-functie te activeren, de SET toets (ongeveer 2 seconden) ingedrukt houden totdat de zonwering voor 10 seconden zich opent en met een korte sluitingsbeweging aangeeft dat het testen begint. De testfunctie blijft 3 minuten actief. Gedurende deze tijd kunt u de ingestelde wind- en lichtdrempelwaarden controleren zonder hiervoor de activeringstijd af te wachten. Nadat de 3 minuten zijn verstreken, gaat de sensor TM2 X SW terug naar de normale werking. Tijdens het testen blijft de rode LED in de regelinrichting branden.

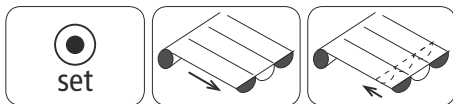

2 sec

#### WINDFUNCTIE TEST

Om fouten te voorkomen, wordt aangeraden om tijdens het testen van de windfunctie, de lichtfunctie uit te zetten. Laat de wieken van de windmeter draaien. Wanneer de gemeten snelheid de ingestelde drempelwaarde overschrijdt, zal de motor de zonwering doen sluiten.

#### LICHTFUNCTIE TEST

Zorg ervoor dat de lichtfunctie actief is. Wanneer de sensor een verschil in de lichtintensiteit waarneemt, zal de zonwering worden geopend of gesloten. Wordt de drempelwaarde overschreden dan wordt deze geopend, zakt de waarde beneden de ingestelde drempelwaarde dan zal de zonwering worden gesloten. Deze test kan meerdere malen herhaald worden totdat de ideale afstelling bereikt is.

# SPECIALE FUNCTIES

## TIJDELIJKE MEMORISATIE VAN DE AFSTANDSBEDIENING

Door middel van deze functie kunt u een afstandsbediening tijdelijk memoriseren, bijvoorbeeld voor het instellen van de eindschakelaars tijdens de montage in de fabriek. De definitieve AB-memorisatie kan later geschieden d.m.v. de betreffende reeks opdrachten (zie MEMORISATIE VD EERSTE AFSTANDSBEDIENING).

De volgende stappen zijn uitsluitend van toepassing als de regeleenheid nieuw af fabriek is. Anders dient u eerst het geheugen volledig te wissen (zie "TOTALE UITWISSING VAN HET AB-GEHEUGEN"). Om ervoor te zorgen dat deze tijdelijke functie uitsluitend t.b.v. het initieel instellen of afstellen toegepast wordt, en dus niet bij normaal gebruik, is de regeleenheid zodanig ingesteld dat er voor de volgende stappen een tijdslimiet geldt. Voedt de regeleenheid en zorg ervoor dat er geen andere regeleenheden, met leeg geheugen, binnen het bereik van de afstandsbediening aanwezig zijn.

**Binnen 30 seconden na het aansluiten**, druk tegelijkertijd de toetsen B en C in, totdat de regeleenheid het bevestigende signaal heeft afgegeven.

**De afstandsbediening blijft gedurende 5 minuten gememoriseerd**, terwijl de regeleenheid gevoed wordt.

Nadat de 5 minuten zijn verstreken, of wanneer de regeleenheid niet meer onder spanning staat, wordt de afstandsbediening gewist.

T1: Memorisatie eerste afstandsbediening

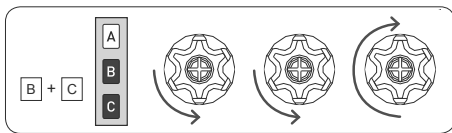

T1

## EU-CONFORMITEITSVERKLARING

De fabrikant FAAC S.p.A. Soc. Unipersonale verklaart dat het type radioapparatuur merk FAAC model TM2 X R MINI voldoet aan de toepasselijke geharmoniseerde normen van de Unie: Richtlijn 2014/53/EU, Richtlijn 2011/65/EU. De volledige tekst van de EU-conformiteitsverklaring is beschikbaar op de volgende website: **<http://www.faac.biz/certificates>**

Bologna, 17-09-2018

CEO A. Marcellan



NL

# FAAC

FAAC S.p.A. Soc. Unipersonale  
Via Calari, 10 - 40069 Zola Predosa BOLOGNA - ITALY  
Tel. +39 051 61724 - Fax +39 051 09 57 820  
[www.faac.it](http://www.faac.it) - [www.faacgroup.com](http://www.faacgroup.com)



A4518\_6H82\_Rev.A