

QUICK START GUIDE

1] PRODUCT PRESENTATION

The RCBO is a handle accessory that allows for a cylinder lock and handle to be maintained on a door fitted with a magnetic architectural handle.

It's useful when a site requires electronic locking during the day and mechanical locking at night. It is manufactured in recyclable UV-resistant material.

The RCBO is compatible with: BO600RP, BO900RP, BO600EVO, and BO900EVO.

Installation is simple. Cut the handle profile at a 90° angle, and click the insert into place. It's quick and easy. It is also aesthetically pleasing, reversible and guaranteed for 10 years by CDVI.

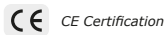

2] MOUNTING

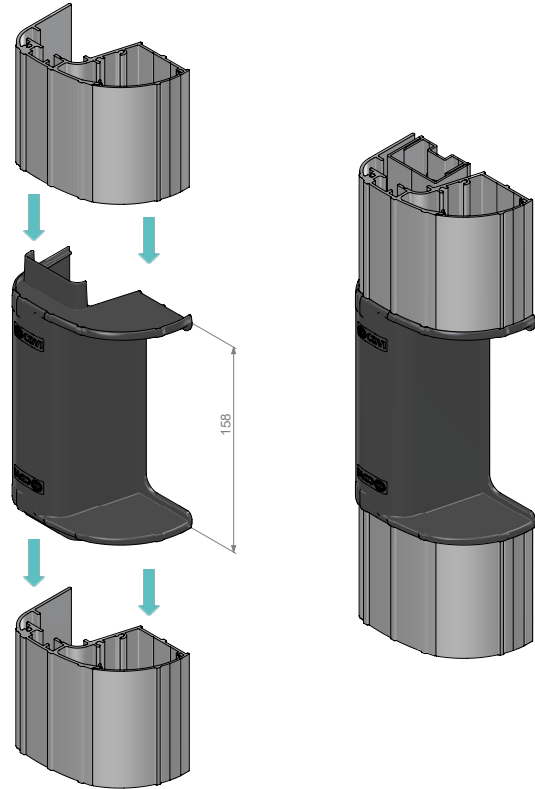

3] QUICK INSTALLATION

1. Cut your aluminium handle to fit the RCBO opposite your existing cylinder. *(The recommended length of the cuts is 158 mm).*
2. Fit the RCBO onto the lower part of the handle section.
3. Fit the upper part of the handle onto the RCBO.

Send us back the 158 mm cut and you'll receive a gift... (exclusively for the French market).

The RCBO in 3D



GUIDE D'INSTALLATION RAPIDE

1] PRESENTATION PRODUIT

Le RCBO de CDVI est un accessoire fabriqué en France dans un matériau recyclable et résistant aux UV.

Il permet l'installation d'un bandeau ventouses BO600RP ou BO600EVO tout en conservant le cylindre existant et s'installe très simplement.

Désormais, la sécurité des biens et des personnes pourront être garanties grâce au BO600RP et son RCBO : contrôle d'accès le jour et condamnation à clé la nuit de vos accès...

Le RCBO est compatible avec la gamme de bandeaux ventouses BO600RP et BO600EVO. Il est également esthétique et réversible et garantie 10 ans par CDVI.



DEEE & RoHS



CE Certification



-40°C à +70°C



IK10

2] MONTAGE

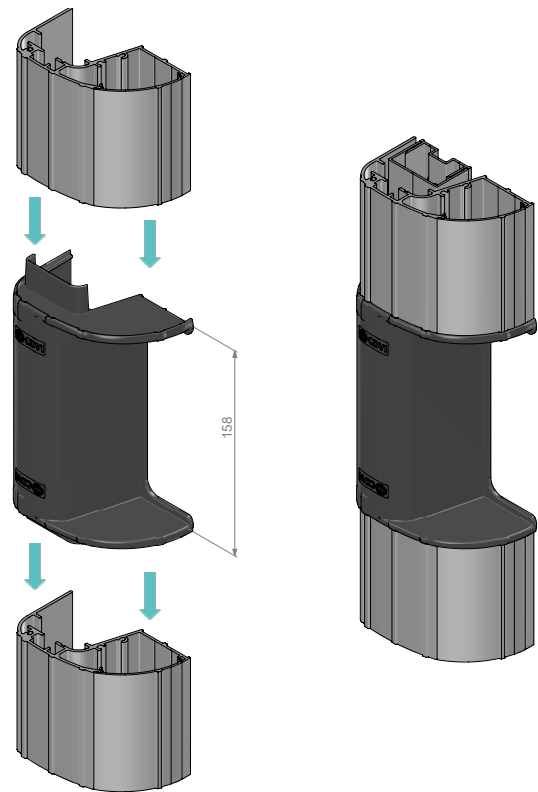

3] POSE RAPIDE

1. Découper votre poignée aluminium pour embôter le RCBO en face de votre cylindre existant. *(La longueur conseillée de la coupe est de 158 mm).*
2. Emboîter le RCBO sur la partie inférieure du bandeau.
3. Emboîter la partie supérieure du bandeau sur le RCBO.

Renvoyez-nous la partie coupée de 158 mm et vous recevrez un cadeau (exclusivement pour le marché français).

Le RCBO en 3D

