

**DOMINA CLASSIC**

GSG INTERNATIONAL  
S.p.A.  
Via Tubertini, 1  
40054 Budrio  
Bologna - Italy

4 7 6 0 1 4 1 13

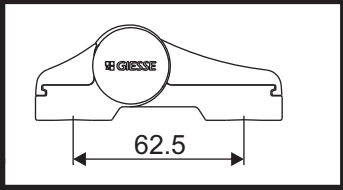

GSG INTERNATIONAL  
S.p.A.  
Via Tubertini, 1  
40054 Budrio  
Bologna - Italy

4 7 5 0 1 4 1 12

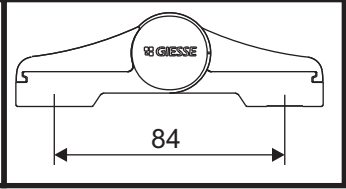
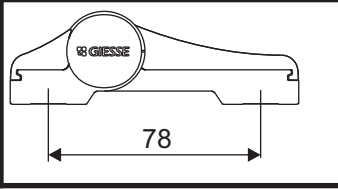
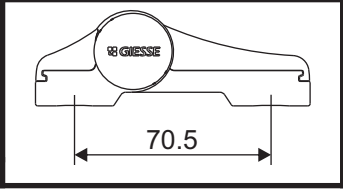

GSG INTERNATIONAL  
S.p.A.  
Via Tubertini, 1  
40054 Budrio  
Bologna - Italy

4 7 4 0 1 4 1 11

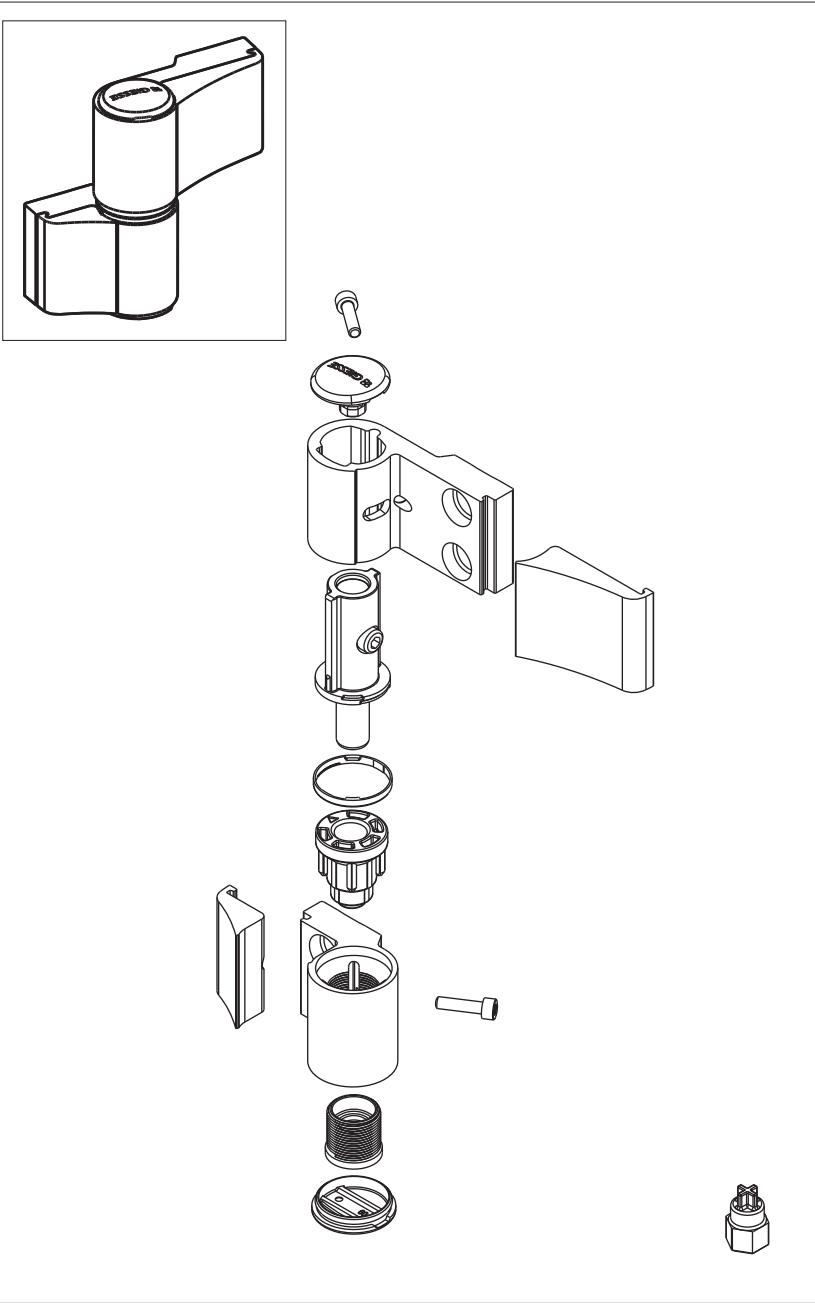
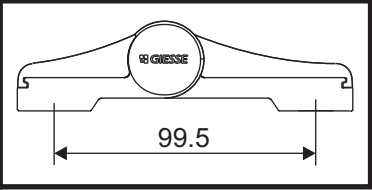
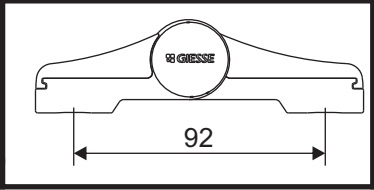

**AVVERTENZE GENERALI - GENERAL WARNINGS - NOTICES GÉNÉRALES  
 ADVERTENCIAS GENERALES - ALLGEMEINE ANWEISUNGEN**

Le classificazioni si riferiscono alle prestazioni della singola cerniera testate secondo EN1935:2002. Per l'effettiva portata della cerniera in funzione del numero e del tipo di cerniera, del tipo di fissaggio, delle caratteristiche del profilo e delle dimensioni e peso della porta, fare riferimento alla sezione COEFFICIENTE DI RIDUZIONE PESO ANTA (CRP)

In caso di applicazione su porte con alta frequenza di apertura, è fortemente raccomandata la lubrificazione del perno della cerniera con grasso, da ripetere almeno due volte all'anno.

L'efficacia e la sicurezza del prodotto sono garantite dall'osservanza di queste istruzioni, pertanto si raccomanda di leggerle attentamente e comprenderle bene prima di utilizzare il prodotto.

Il prodotto è stato progettato per essere installato con facilità. Occorre seguire attentamente le istruzioni di montaggio, smontaggio e manutenzione qui riportate. Si consiglia di far installare il prodotto da personale specializzato.

Utilizzare esclusivamente gli accessori consigliati nel presente documento.

Il prodotto è costruito secondo le vigenti normative europee.

È essenziale che vengano rispettati i limiti di impiego previsti dal Produttore.

Responsabilità e garanzia del Produttore decadono se non vengono rispettati i limiti di impiego e/o se per gli accessori previsti, non vengono seguite le istruzioni di montaggio riportate nel presente documento.

Classifications refer to the performance of a single hinge tested as provided by EN1935:2002. For the effective load capacity of the hinge as a function of the number and type of hinges used, type of mounting, characteristics of the profile and size and weight of the door, see the DOOR WEIGHT REDUCTION COEFFICIENT (CRP).

If fitted to doors subject to heavy service, we recommend lubricating the hinge pin with grease at least twice a year.

The effectiveness and safety of the product depend on these instructions being observed; read them carefully before using the product.

The product is designed for easy installation. Follow the installation, removal and maintenance instructions given in this publication.

We recommend that the product be installed by a qualified technician. Only use the accessories recommended in this publication.

The product satisfies current EU regulations. The Manufacturer's specified limits of use must be observed scrupulously.

The Manufacturer is not liable if the limits of use are ignored and the recommended accessories are not employed, and if the installation instructions given in this publication are not followed to the full.

Les classifications se réfèrent aux prestations de chaque paumelle testée conformément à la norme EN1935:2002. Pour la capacité effective de la paumelle en fonction du nombre et du type de paumelle, du type de fixation, des caractéristiques du profil et des dimensions et du poids de la porte, faire référence à la section COEFFICIENT DE RÉDUCTION DU POIDS DU VANTAIL (CRP)

En cas d'application sur des portes particulièrement utilisées, il est fortement recommandé de lubrifier l'axe de la paumelle avec de la graisse (répéter l'opération au moins deux fois par an).

L'efficacité et la sécurité de la pièce dépendent du respect de ces instructions, il est donc recommandé de les lire attentivement et de bien les comprendre avant d'utiliser la pièce.

L'article a été conçu pour être installé avec facilité. Il suffit de suivre attentivement les instructions de montage, démontage et entretien citées sur ces pages. Il est conseillé de confier l'installation de l'article à un technicien spécialisé.

Utiliser exclusivement les accessoires conseillés dans ce document.

L'article a été réalisé conformément aux normes européennes en vigueur.

Respecter impérativement les limites d'emploi prévues par le fabricant.

La responsabilité et la garantie du fabricant cessent si les limites d'emploi ne sont pas respectées, si les accessoires prévus ne sont pas utilisés et si les instructions de montage prévues dans ce document ne sont pas respectées.

Las clasificaciones se refieren a las prestaciones de cada bisagra, probadas según la norma EN1935:2002. Para la capacidad efectiva de la bisagra según el número y el tipo de bisagra, el tipo de fijación, las características del perfil y las dimensiones y el peso de la puerta, consultar la sección COEFICIENTE DE REDUCCIÓN PESO HOJA (CRP).

En caso de aplicación en puertas con alta frecuencia de apertura se recomienda lubricar el perno de la bisagra con grasa al menos dos veces al año.

La eficacia y la seguridad del producto están garantizadas sólo si se cumplen estas instrucciones.

Por lo tanto, se recomienda leerlas con detenimiento y comprenderlas bien antes de utilizar el producto.

El producto ha sido diseñado para instalarse con facilidad.

Seguir detenidamente las instrucciones de montaje, desmontaje y mantenimiento.

Se recomienda hacer instalar el producto a personal especializado.

Utilizar exclusivamente los accesorios recomendados en este documento.

El producto está construido según las normas europeas vigentes.

Es fundamental respetar los límites de empleo previstos por el fabricante.

La responsabilidad y la garantía del fabricante quedan sin efecto si no se respetan los límites de empleo y/o el uso de los accesorios previstos o si no se cumplen las instrucciones de montaje contenidas en este documento.

Die Einstufungen beziehen sich auf die Leistungen des einzelnen Bands, das nach Norm EN1935:2002 geprüft ist. Für die effektive Tragfähigkeit des Bands in Abhängigkeit von der Anzahl der Bänder, des Bandtyps, der Befestigungsart, der Profilmernkmale, der Abmessungen und des Gewichtes der Tür siehe den Abschnitt REDUKTIONSFAKTOR DES FLÜGELGEWICHTES (CRP)

Werden die Bänder auf Türen mit hoher Öffnungsbeanspruchung eingesetzt, wird empfohlen, die Zapfen der Bänder mindestens zwei Mal pro Jahr einzufetten.

Die Wirksamkeit und die Sicherheit des Produktes sind nur bei strikter Einhaltung der vorliegenden Anweisungen gewährleistet; es wird daher geraten, die Anweisungen vor dem Gebrauch des Produktes sorgfältig zu lesen und sich zu vergewissern, den Inhalt voll verstanden zu haben.

Das Produkt ist für einfache und schnelle Montage gebaut.

Lesen Sie sorgfältig die vorliegenden Montage-, Ausbau- und Wartungsanweisungen.

Es wird empfohlen, das Produkt von Fachkräften installieren zu lassen.

Ausschließlich das in dem vorliegenden Dokument empfohlene Zubehör verwenden.

Das Produkt ist in Entsprechung der gültigen europäischen Richtlinien hergestellt.

Es ist wichtig, dass die vom Hersteller vorgegebenen Anwendungsgrenzen strikt eingehalten werden.

Die Produkthaftung und die Garantie des Herstellers verfallen, wenn die Anwendungsgrenzen nicht eingehalten und/oder für das Zubehör die im vorliegenden Dokument aufgeführten Montageanweisungen missachtet werden.

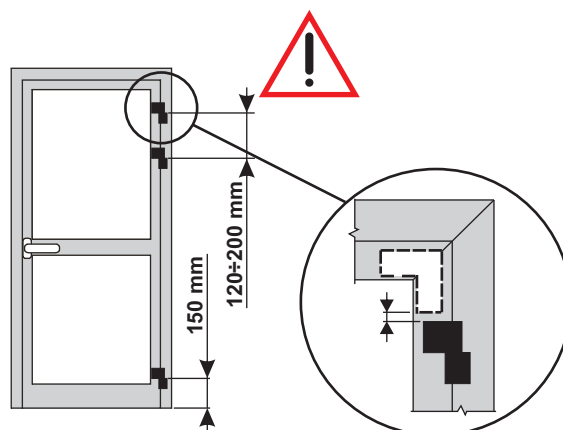
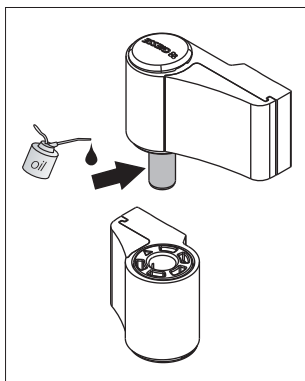

**ATTREZZI NECESSARI PER IL MONTAGGIO  
TOOLS REQUIRED FOR MOUNTING  
FÜR DIE MONTAGE ERFORDERLICHE WERKZEUGE  
HERRAMIENTAS NECESARIAS PARA EL MONTAJE  
OUTILS NÉCESSAIRES POUR LE MONTAGE**

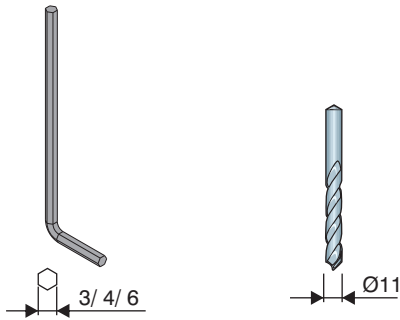

03237000

05052000

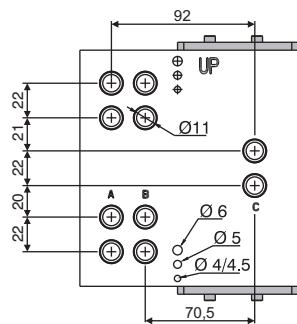
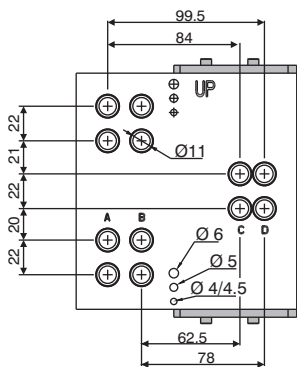

**LAVORAZIONI - WORKING - USINAGES  
MECANIZADO - BEARBEITUNG**

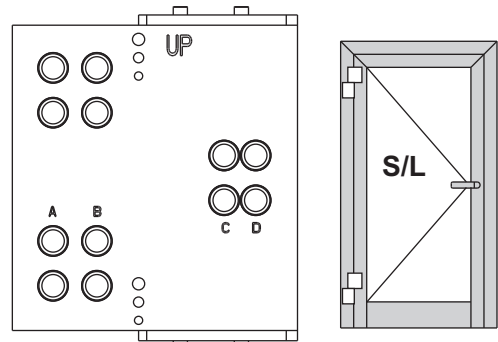
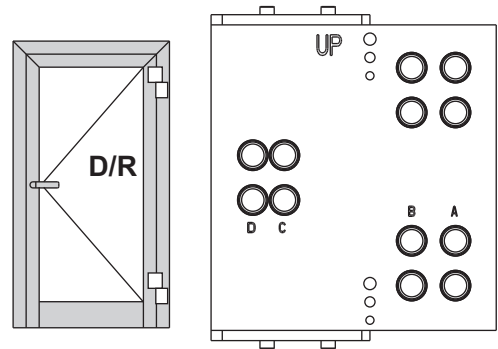

**USO DELLA DIMA  
TEMPLATE USING  
UTILISATION DU GABARIT  
USO DE LA PLANTILLA  
ANWENDUNG DER BOHLEHRE**

**COMPLANARE - FLUSH  
COPLANAIRE - COPLANAR - BÜNDIG**

**SORMONTO - OVERLAP  
RECouvreMENT - RESALTE - ÜBERLAPPUNG**

**DIMA CON SPINE  
TEMPLATE WITH PLUGS  
GABARIT AVEC CHEVILLES  
PLANTILLA CON TOPES  
BOHLEHRE MIT STECKER**

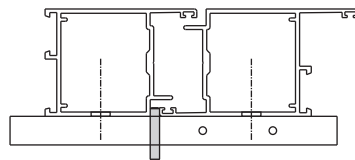

**DIMA CON POSIZIONATORI  
MACHINE - TEMPLATE WITH  
PLACERS  
GABARIT AVEC POSITIONNEURS  
PLANTILLA CON POSICIONADORES  
BOHLEHRE MIT  
POSIZIONIERERVORRICHTUNGEN**

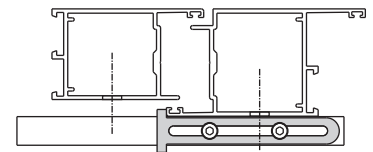
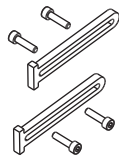

**FORATURA  
DRILLING  
PERÇAGE  
TALADRO  
BOHRUNG**

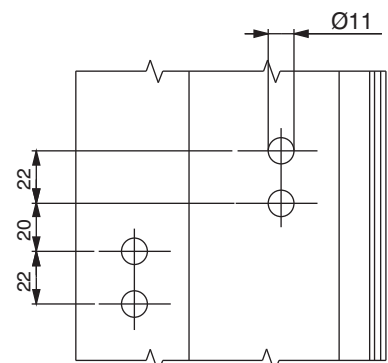
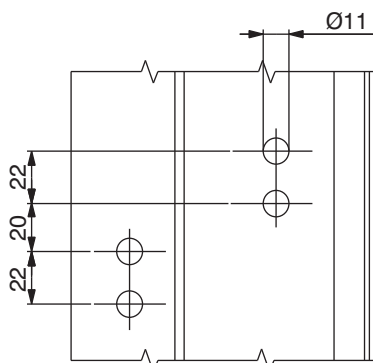

## PORTATE MASSIME - MAXIMUM LOADS - CAPACIDADES MÁXIMAS - CHARGES MAXIMUM - MAXIMALEN TRAGFÄHIGKEITEN

Le portate sotto indicate sono valide anche per cerniere non complanari (gradino abbinato)

The specified load capacities also apply to non-flush hinges (combined step)

Les charges indiquées ci-dessus sont également valables pour les paumelles non coplanaires (cran assemblé)

Las capacidades antedichas son válidas también para las bisagras no coplanares (escalonado combinado)

Die o. A. Tragfähigkeiten gelten auch für flächenversetzte Bänder (kombistufe)

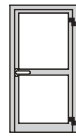

Pmax



Pmax



Pmax



Pmax \*

\* CON FRENO IN APERTURA  
WITH BACK-CHECK FACILITY  
ABERTURA CON FRENO  
AVEC FERME PORTE  
MIT BREMSE BEIM ÖFFNEN

		120 kg	140 kg	120 kg	80 kg
		100 kg	120 kg	100 kg	70 kg
		100 kg	120 kg	100 kg	70 kg
		100 kg	120 kg	100 kg	70 kg
		80 kg	100 kg	80 kg	60 kg
		80 kg	100 kg	80 kg	60 kg

		120 kg	140 kg	120 kg	80 kg
		100 kg	120 kg	100 kg	70 kg
		100 kg	120 kg	100 kg	70 kg
		100 kg	120 kg	100 kg	70 kg
		80 kg	100 kg	80 kg	60 kg
		80 kg	100 kg	80 kg	60 kg

		100 kg	120 kg	100 kg	70 kg
		80 kg	100 kg	80 kg	60 kg
		80 kg	100 kg	80 kg	60 kg
		80 kg	100 kg	80 kg	60 kg
		60 kg	80 kg	60 kg	50 kg
		60 kg	80 kg	60 kg	50 kg

**COEFFICIENTE DI RIDUZIONE PESO ANTA (CRP) IN FUNZIONE DELLE DIMENSIONI**  
**DOOR WEIGHT REDUCTION COEFFICIENT (CRP) AS A FUNCTION OF SIZE**  
**COEFFICIENT DE RÉDUCTION DU POIDS DU VANTAIL (CRP) EN FONCTION DES DIMENSIONS**  
**COEFICIENTE DE REDUCCIÓN PESO HOJA (CRP) SEGÚN LAS DIMENSIONES**  
**REDUKTIONSFAKTOR DES FLÜGELGEWICHTES (CRP) IN ABHÄNGIGKEIT VON DEN ABMESSUNGEN**

Altezza anta (mm) - Altura hoja (mm) - Wing height (mm) - Flügelhöhe (mm) - Hauteur vantail (mm)	4000	1	1	1	1	1	1	1	1	1	1	1	1	1	1	1	1	1	1
	3900	1	1	1	1	1	1	1	1	1	1	1	1	1	1	1	1	1	0,95
	3800	1	1	1	1	1	1	1	1	1	1	1	1	1	1	1	1	1	0,90
	3700	1	1	1	1	1	1	1	1	1	1	1	1	1	1	1	1	0,95	0,87
	3600	1	1	1	1	1	1	1	1	1	1	1	1	1	1	1	1	0,90	0,83
	3500	1	1	1	1	1	1	1	1	1	1	1	1	1	1	1	0,94	0,86	0,80
	3400	1	1	1	1	1	1	1	1	1	1	1	1	1	1	0,90	0,83	0,77	
	3300	1	1	1	1	1	1	1	1	1	1	1	1	0,94	0,85	0,79	0,75		
	3200	1	1	1	1	1	1	1	1	1	1	1	1	0,89	0,82	0,76	0,71		
	3100	1	1	1	1	1	1	1	1	1	1	1	0,94	0,85	0,78	0,73	0,69		
	3000	1	1	1	1	1	1	1	1	1	1	1	0,88	0,81	0,75	0,70	0,67		
	2900	1	1	1	1	1	1	1	1	1	1	0,93	0,84	0,76	0,72	0,68	0,65		
	2800	1	1	1	1	1	1	1	1	1	0,88	0,80	0,74	0,69	0,65	0,63			
	2700	1	1	1	1	1	1	1	1	0,93	0,83	0,76	0,71	0,67	0,63	0,61			
	2600	1	1	1	1	1	1	1	1	0,88	0,79	0,72	0,68	0,64	0,61	0,59			
	2500	1	1	1	1	1	1	1	0,93	0,83	0,75	0,69	0,65	0,62	0,60	X			
	2400	1	1	1	1	1	1	0,87	0,78	0,71	0,67	0,63	0,60	X	X				
	2300	1	1	1	1	1	0,93	0,81	0,74	0,68	0,64	0,61	X	X	X				
	2200	1	1	1	1	1	0,85	0,76	0,70	0,65	0,61	X	X	X	X				
2100	1	1	1	1	1	0,91	0,80	0,72	0,67	0,63	0,59	X	X	X	X				
2000	1	1	1	1	1	0,85	0,75	0,68	0,64	0,60	X	X	X	X	X				
		600	700	800	900	1000	1100	1200	1300	1400	1500	1600	1700	1800	1900	2000			

Dimensioni non realizzabili  
 Not possible dimensions  
 Dimensiones no admitidas  
 Dimensions Irréalizable  
 Nicht zulässige abmessungen

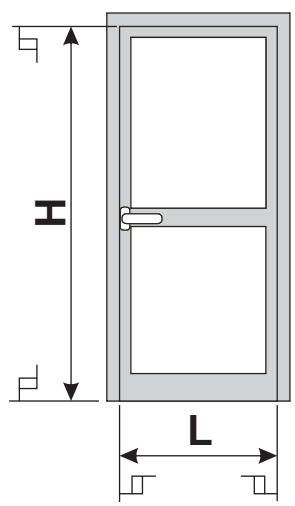

**L** Larghezza anta (mm) - Anchura hoja (mm) - Wing width (mm)  
 Flügelbreite (mm) - Largeur vantail (mm)

Pour obtenir le poids maximum effectif (P) de l'ouvrant, il faut multiplier la valeur Pmax choisie dans le **Tableau des charges maximum** (page 4) par le coefficient de réduction du poids (CRP) correspondant aux dimensions du châssis.  
**Exemple:**  
 L x H = 1200 x 2800 mm  
 n°2 paumelles 62,5 avec contre plaques  
 épaisseur profil 1,8 mm  
 Pmax = 120 kg  
 CRP = 1  
 P = 120 x 1 = 120 kg

Per ottenere il peso massimo effettivo (P) dell'anta, moltiplicare il valore Pmax scelto nella **Tabella delle portate massime** (pag. 4) per il coefficiente di riduzione peso (CRP) corrispondente alle dimensioni dell'infisso (LxH).  
**Esempio:**  
 L x H = 1200 x 2800 mm  
 n°2 cerniere 62,5 con contropiastre  
 spessore profilo 1,8 mm  
 Pmax = 120 kg  
 CRP = 1  
 P = 120 x 1 = 120 kg

Para obtener el peso máximo efectivo (P) de la hoja, multiplicar el valor Pmax elegido en la **Tabla de capacidades máximas** (pág. 4) por el coeficiente de reducción peso (CRP) correspondiente a las dimensiones del cerramiento (LxH).  
**Ejemplo:**  
 L x H = 1200 x 2800 mm  
 2 bisagras 62,5 con contraplaca  
 espesor perfil 1,8 mm  
 Pmax = 120 kg  
 CRP = 1  
 P = 120 x 1 = 120 kg

To obtain the real sash maximum weight (P) multiply the Pmax value chosen in the **Maximum load chart** (page 4) for the weight reduction coefficient (CRP) corresponding to the sash size (W x H)  
**Example:**  
 W x H = 1200 x 2800 mm  
 No. 2 hinges C/C 62,5 with counterplates  
 Profile thickness 1,8 mm  
 Pmax = 120 kg  
 CRP = 1  
 P = 120 x 1 = 120 kg

Um das effektive Höchstgewicht (P) des Flügels zu erhalten, den der **Tabelle der maximalen Tragfähigkeiten entnommenen Wert Pmax** (Seite 4) mit dem Reduktionsfaktor des Flügelgewichtes (CRP) der betreffenden Türabmessungen (BxH) multiplizieren.  
**Beispiel:**  
 B x H = 1200 x 2800 mm  
 2 Bänder 62,5 mit Schließplatten  
 Profildicke 1,8 mm  
 Pmax = 120 Kg  
 CRP = 1  
 P = 120 x 1 = 120 kg

**ASSEMBLAGGIO CERNIERA - HINGE ASSEMBLY - ASSEMBLAGE PAUMELLE - ENSAMBLAJE BISAGRA - - BANDMONTAGE**

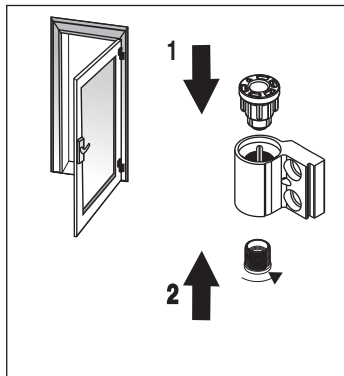
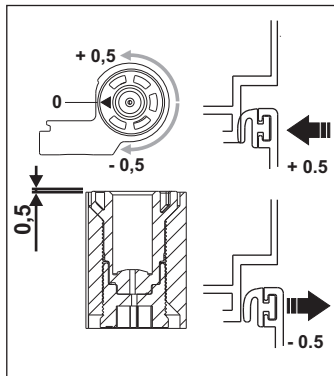
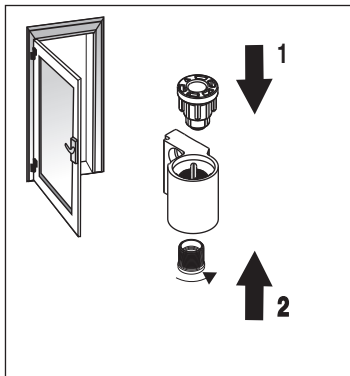
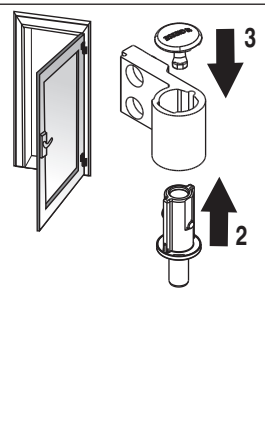
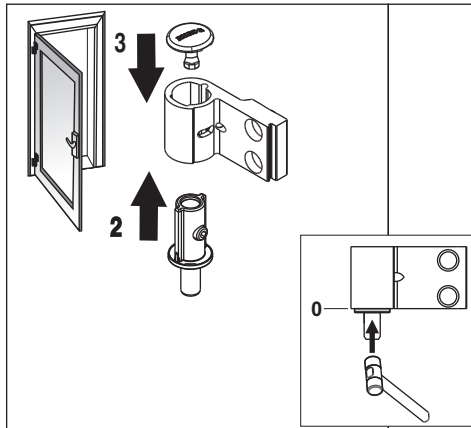
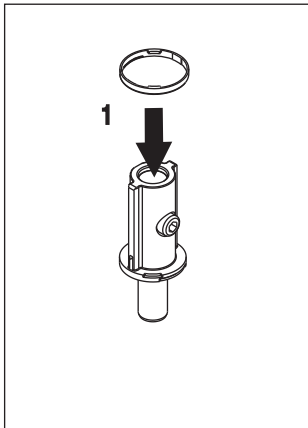

**SISTEMI DI FISSAGGIO-FIXING SYSTEMS-SYSTEMÈS DE FIXATION-SISTEMA DE FIJACIÓN-BEFESTIGUNGSSYSTEME**

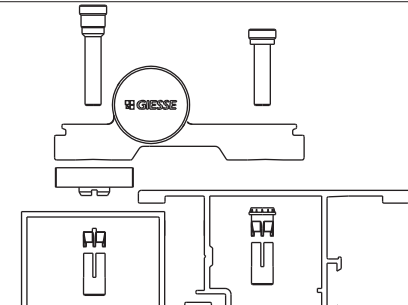
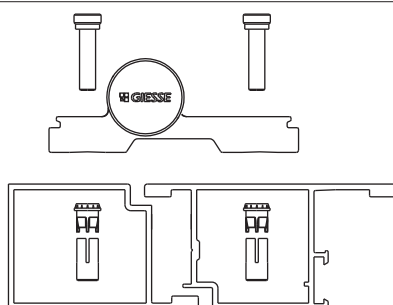
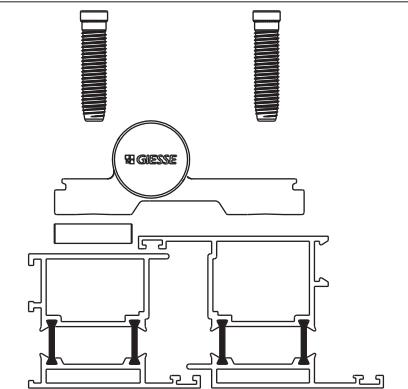
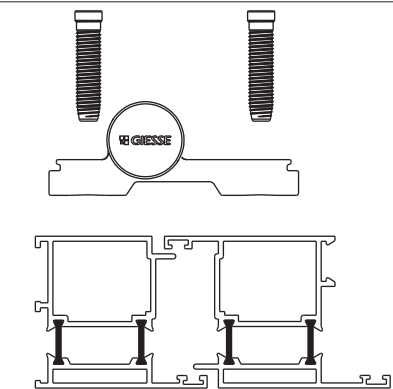
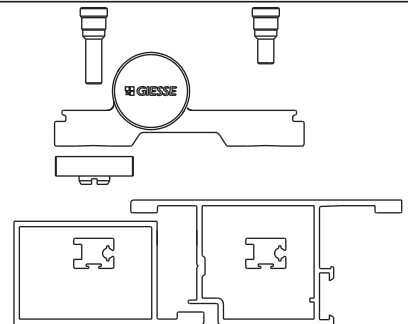
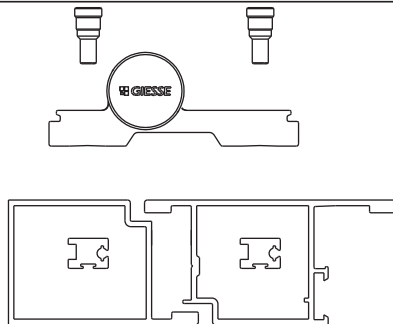

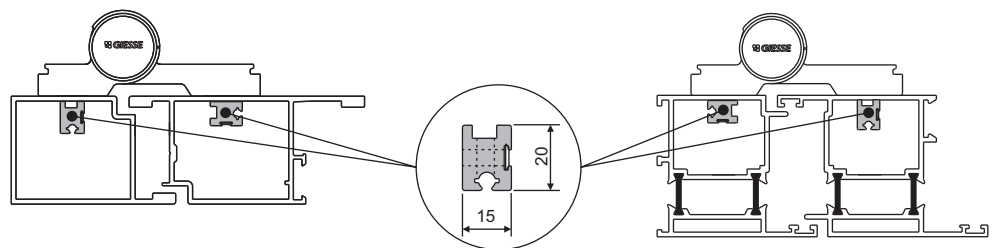
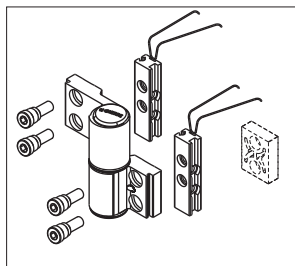
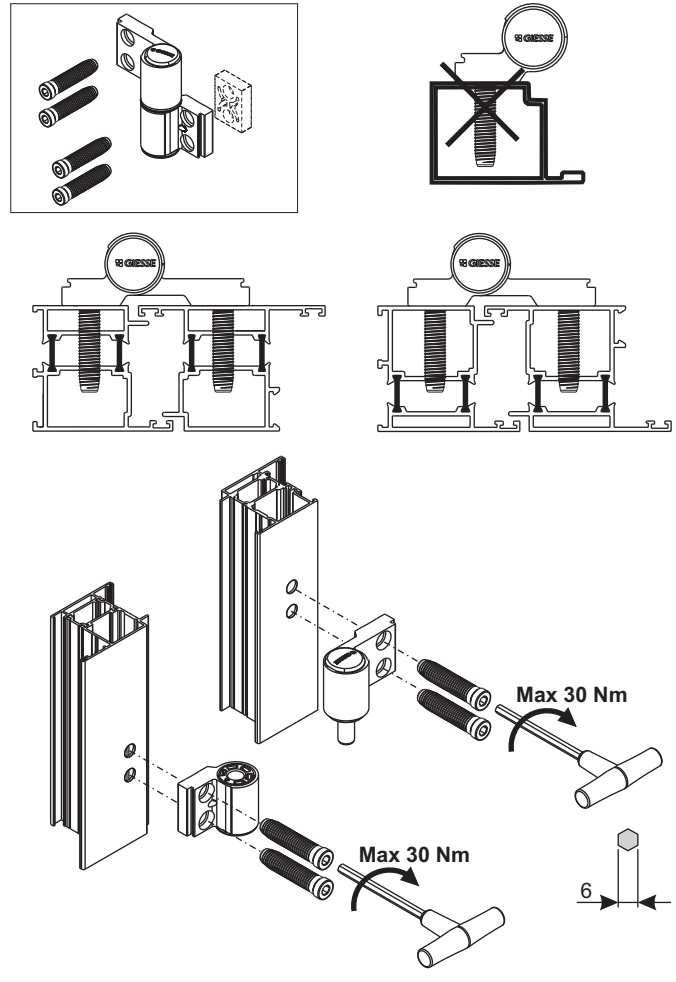
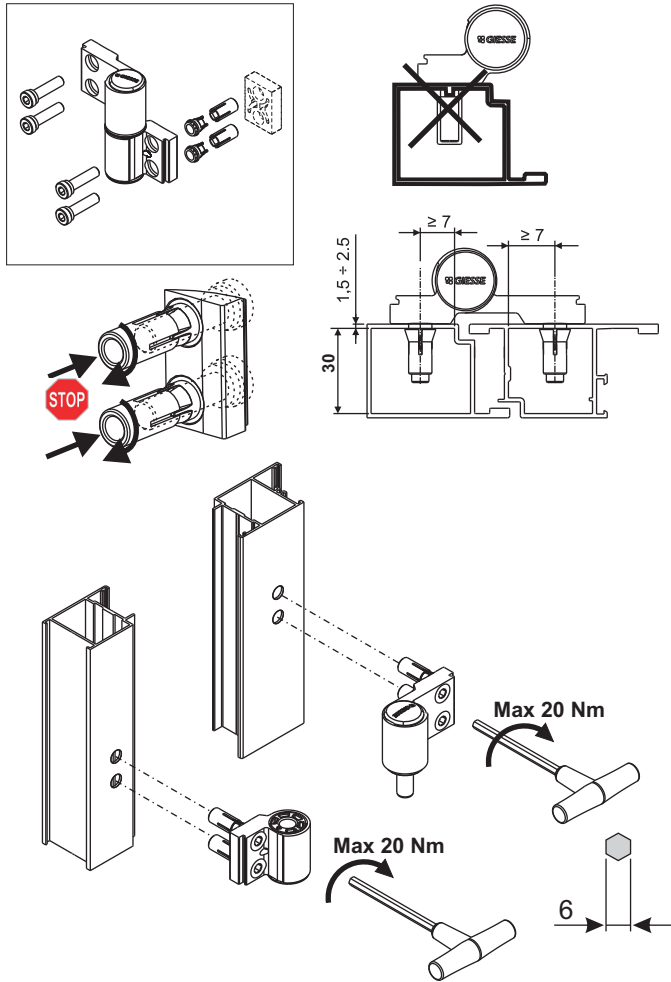

SOLO APERTURA ESTERNA  
OUTWARD OPENING ONLY  
UNIQUEMENT OUVERTURE VERS L'EXTÉRIEUR  
PARA APERTURA EXTERNA  
NUR FYR AUSSEN ERÖFFNUNG

03238000

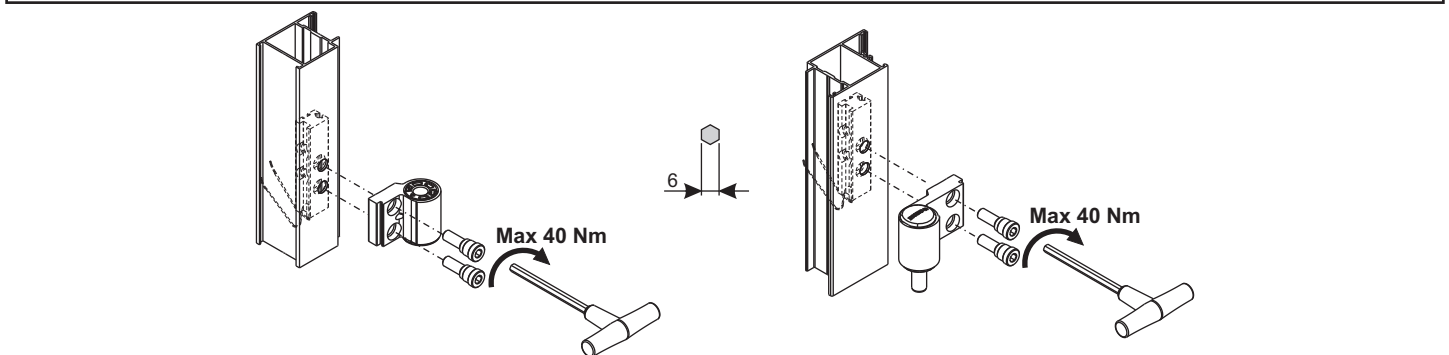
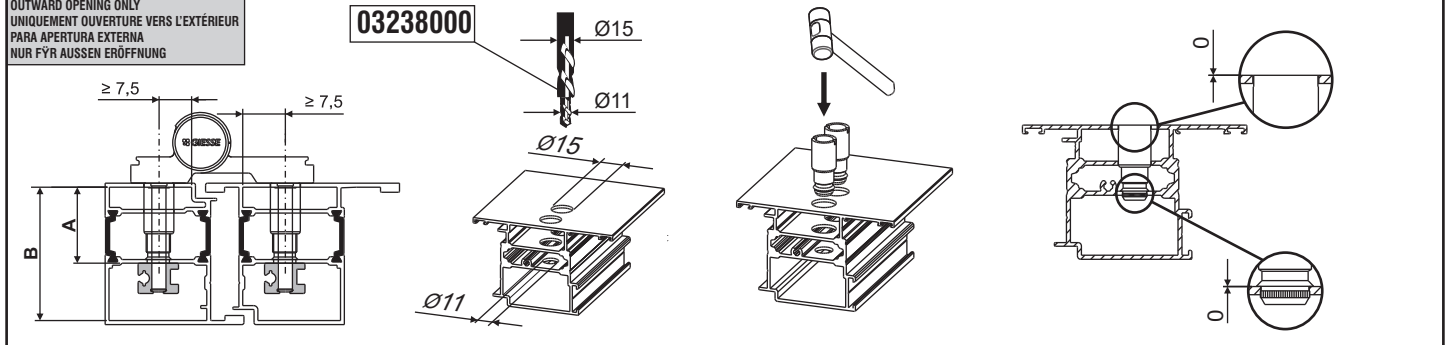

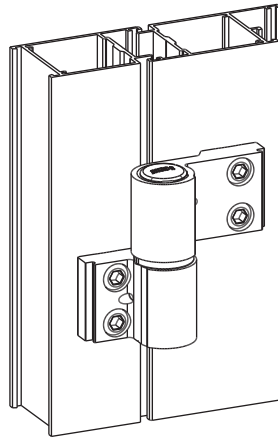

**REGOLAZIONI - ADJUSTMENTS - RÉGLAGES - REGULACIONES - JUSTAGE**

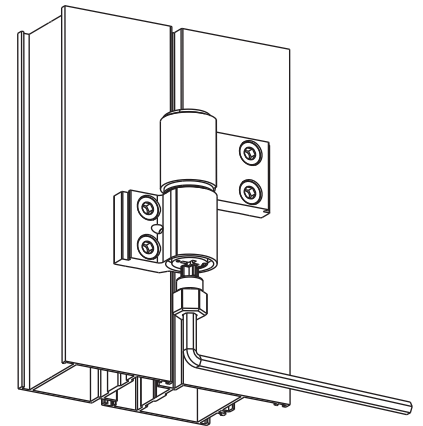
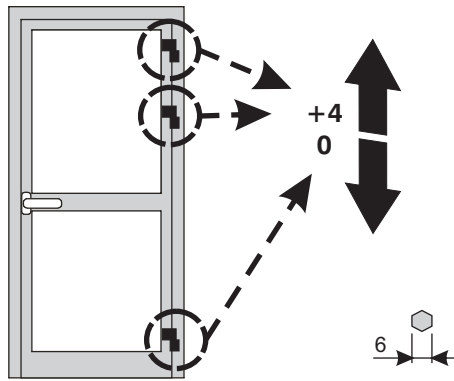
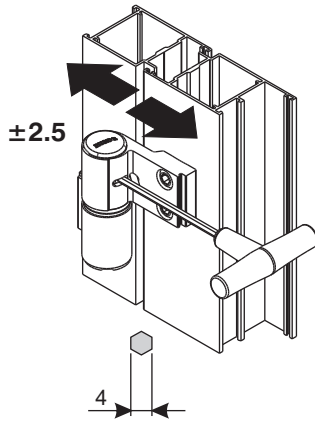

**OPERAZIONI FINALI - FINAL OPERATIONS - OPÉRATIONS FINALES - OPERACIONES FINALES - ENDBEARBEITUNG**

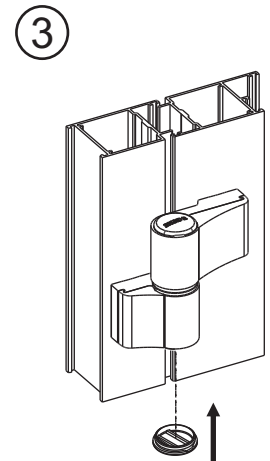
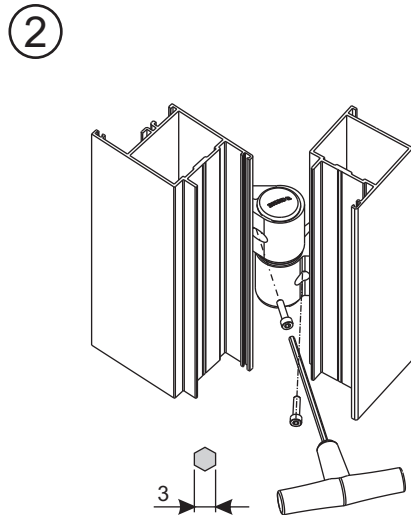
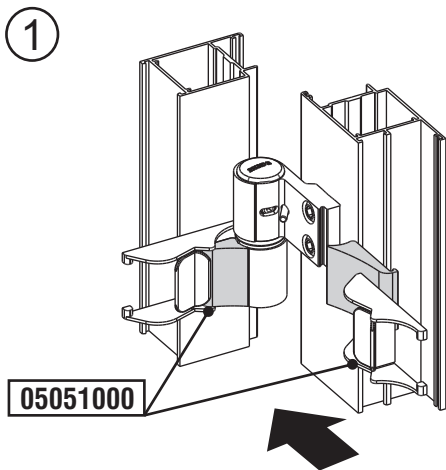

**VERSIONE GREZZO - PLAIN VERSION - VERSION BRUTE - VERSIÓN CRUDA - UNLACKIERTER AUSFÜHRUNG**

