

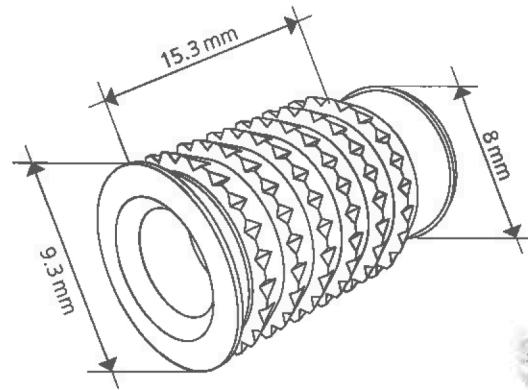

Cabineo Muffe / Cabineo insert

Pat. pend.

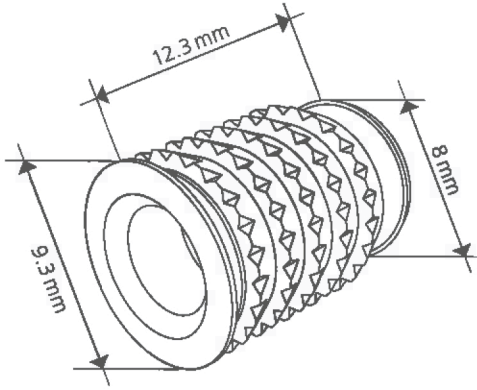

Cabineo Muffe M6x12.3
Cabineo insert M6x12.3

Cabineo Muffe M6x15.3
Cabineo insert M6x15.3

Montage / Assembly:

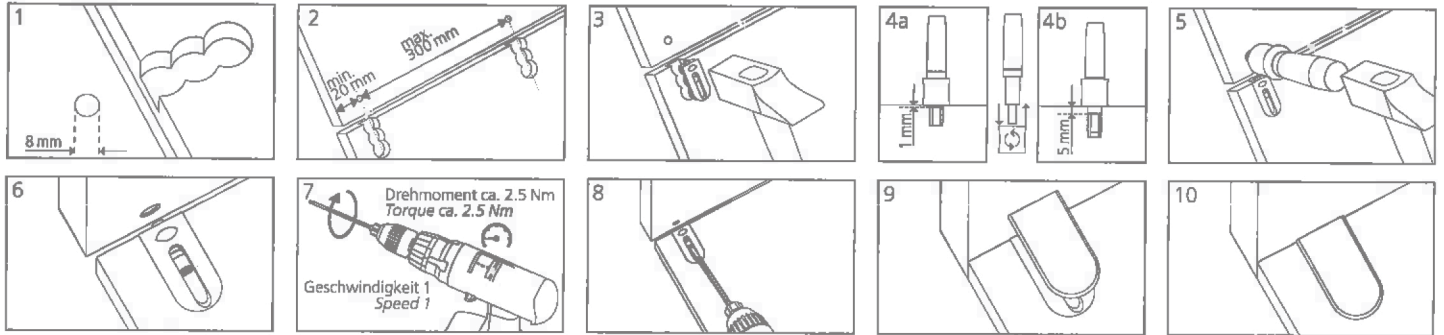

Anwendungen / Applications:

Ab 14 mm Material: Muffe M6x 12.3 / From 14 mm material: insert nut M6x 12.3

Ab 17 mm Material: Muffe M6x 15.3 / From 17 mm material: insert nut M6x 15.3

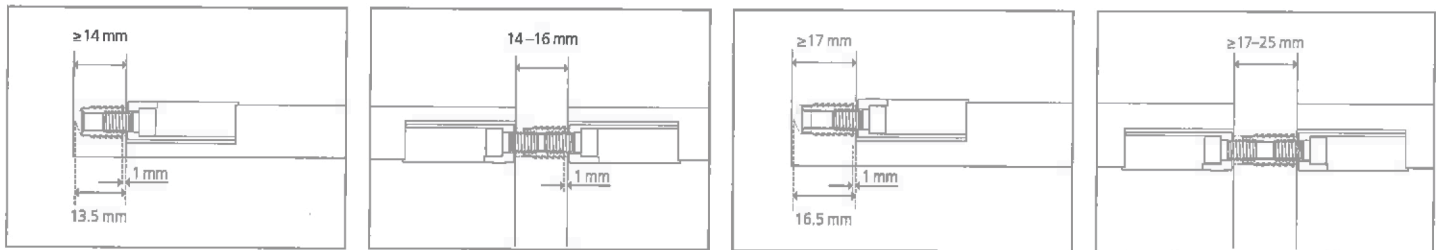

Bearbeitung: Seite / Machining: Side panel

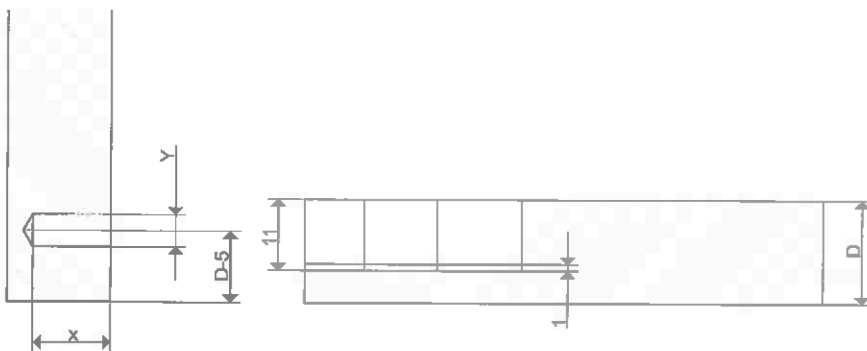

	X [mm]	Y = Ø [mm]
Cabineo 8 M6*	8	5
Muffe / Insert M6x12.3	13.5	8
Muffe / Insert M6x15.3	16.5	8

* Metrisches ISO-Gewinde DIN 13-1 / * Metric ISO thread DIN 13-1



Keine Holzdübel notwendig! / No dowel necessary!

keine Kantenbearbeitung / weniger Bohrungen / weniger Werkzeugwechsel / keine Dübelmontage
no edge drilling / less drill holes / less tool change / no pre-assembly of dowel

