

REVO 90°

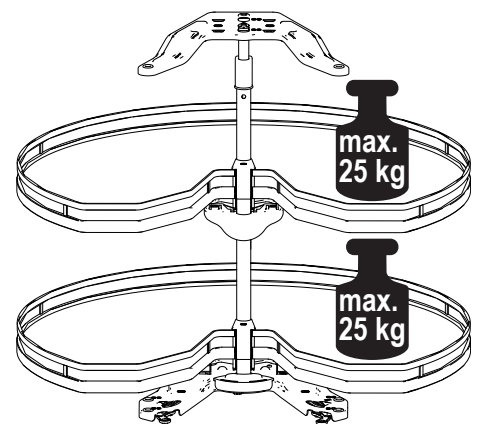

KESSEBÖHMER

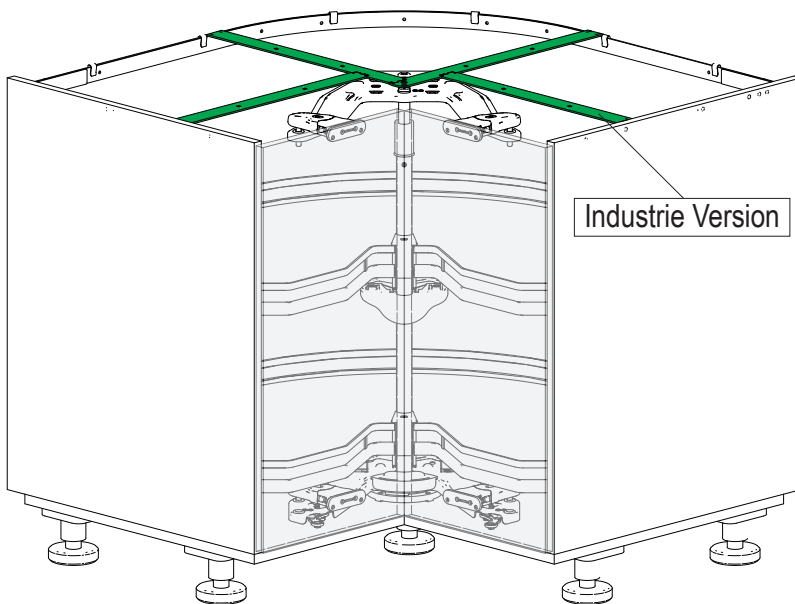
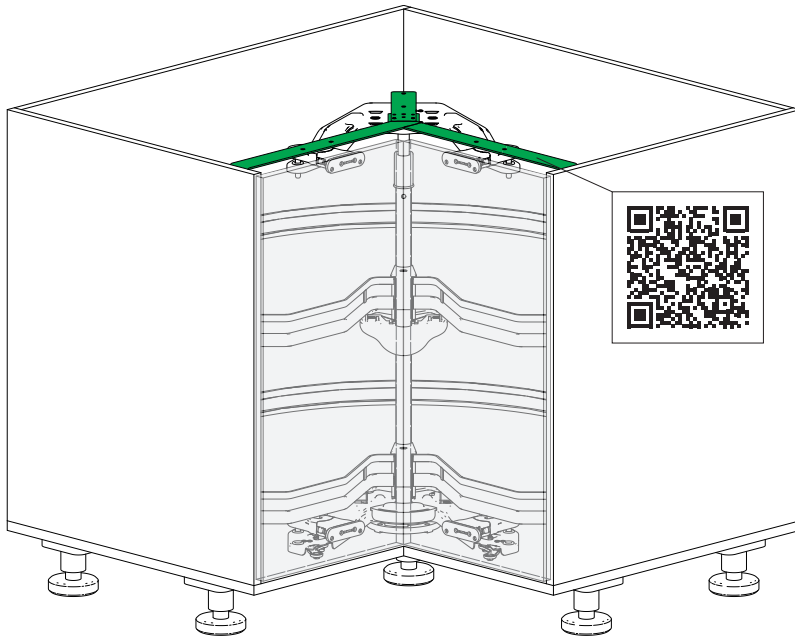
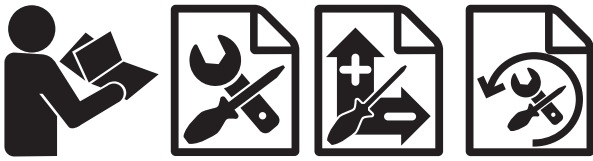

<http://support.kesseboehmer.de>



REVO 90°

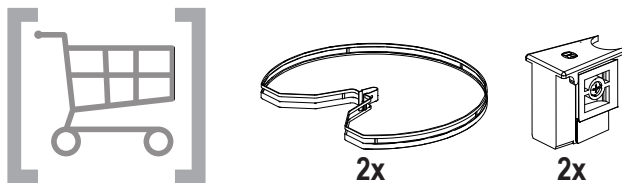
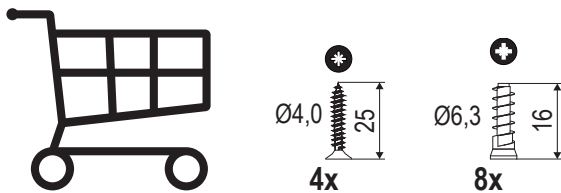
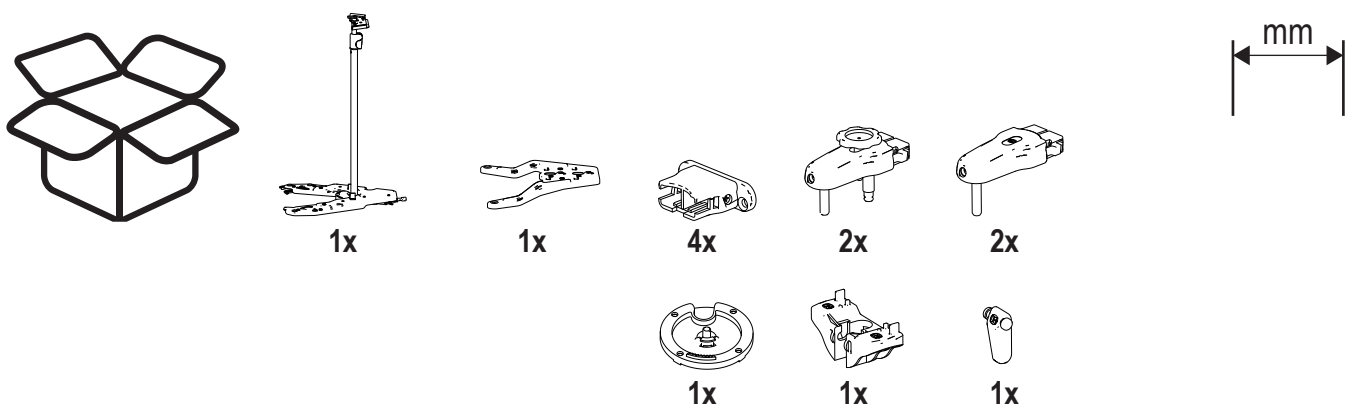

DE Die technischen Darstellungen und Maßangaben – auch bei Abbildungen und Zeichnungen – sind unverbindlich. Konstruktionsverbesserungen sind vorbehalten! **EN** Technical information and stated dimensions (including in illustrations and drawings) must not be regarded as binding. Design subject to improvement without notice! **FR** Les visuels techniques et dimensions – y compris les schémas et les illustrations – ne sont pas contractuelles. Sous réserve d'évolutions techniques! **IT** Le rappresentazioni tecniche e le indicazioni delle dimensioni – anche nelle figure e nei disegni – non sono vincolanti. Con riserva di miglioramenti di progettazione! **ES** Las imágenes técnicas y las indicaciones de medidas – también en imágenes y dibujos – no son vinculantes. Queda reservado el derecho de realizar mejoras en el diseño! **PT** Representações técnicas e dimensões – mesmo em ilustrações e desenhos – não são vinculativas. Reservado o direito a melhorias construtivas! **HE** כל התרשימים הטכניים והמידות - אף לגבי איורים ותכניות - הנם בלתי מחייבים. זכות שינויים ושיפורים מבניים שמורה ליצרן! **FI** Tekniset piirroksset ja mitat – myös kuvissa ja piirroksissa olevat – ovat sitoumuksetta. Oikeus rakennetta parantaviin muutoksiin pidätetään! **DA** De tekniske illustrationer og målangivelser - også på illustrationer og tegninger - er ikke bindende. Forbehold for designforbedringer! **CS** Technické popisy a rozměry, jakož i obrázky a výkresy, jsou nezávazné. Vyhrazuji si právo na změny konstrukce! **PL** Prezentacje techniczne i wymiary – także na ilustracjach i rysunkach – nie są wiążące. Udoskonalenia konstrukcyjne są zastrzeżone! **RU** Иллюстрации технических деталей и указанные размеры, в том числе на рисунках и чертежах, являются ориентировочными. Компания оставляет за собой право на усовершенствование конструкции! **TR** Teknik sunum ve ölçü bilgileri (resim ve çizimlerde de) yasal olarak bağlayıcı değildir. Yapısal geliştirmeler uyarı hakkı saklıdır! **BG** Техническото представяне и размерите, включително при изображенията и чертежите, са необвързващи. Запазваме си правото на конструктивни подобрения! **HU** A műszaki ábrázolások és méretadatok – ábránál és rajzoknál sem – nem kötelező érvényűek. A konstrukciós javítások joga fenntartva! **SR** Tehničke ilustracije i dimenzije - uključujući ilustracije i crteže - nisu obavezujući. Dizajn poboljšanja su rezervisana! **EL** Τα τεχνικά σχήματα και οι διαστάσεις – ακόμα και σε απεικονίσεις και σχέδια – δεν είναι δεσμευτικά. Με την επιφύλαξη τεχνικών βελτιώσεων! **AR** الرسوم التوضيحية والأبعاد الفنية - بما في ذلك الرسوم التوضيحية والرسومات - ليست إلزامية. الحق محفوظ في إجراء تحسينات هيكلية! **JA** 技術情報および記載されている寸法(イラストや図面を含む)は、拘束的のあるものと見なされません。デザインは予告なしに改善されることがあります。 **CN** 技术说明和规格, 包括插图和图纸均不具约束力。保留改进设计的权利!

REVO 90°



1

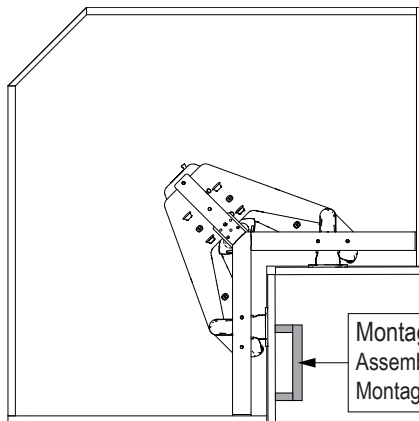
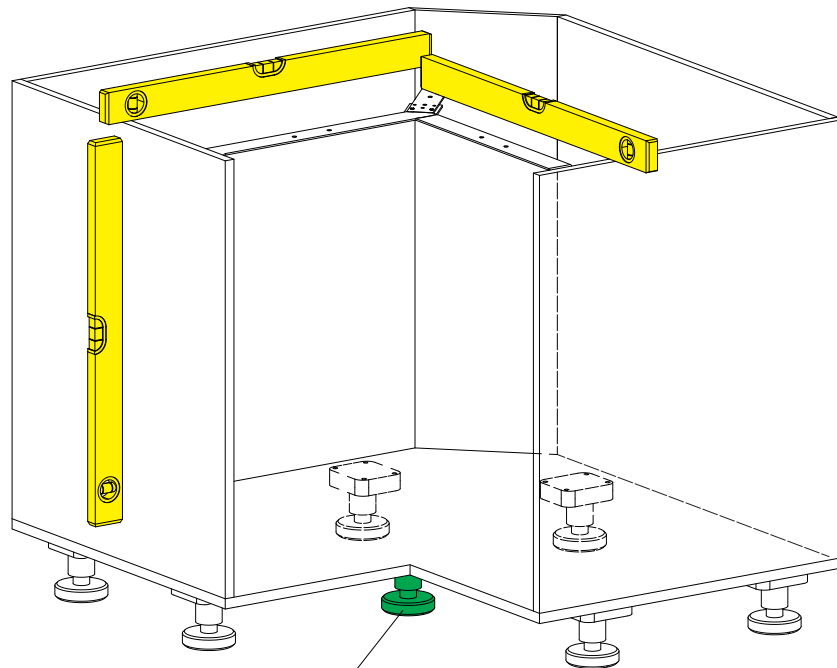
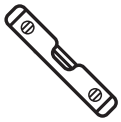

Montage des Frontgriffes vorzugsweise nur links!
Assembly the front handle preferably only left side!
Montage de la poignée de préférence seulement à gauche!

REVO 90°



2a 900

$$G = 900 - B - C + 90,5$$

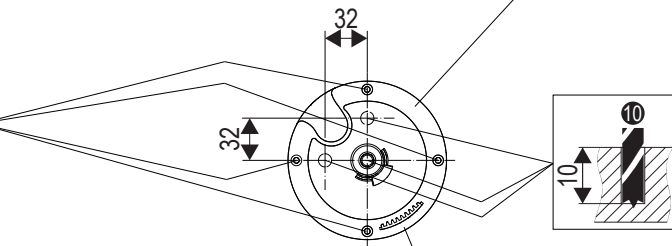
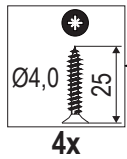
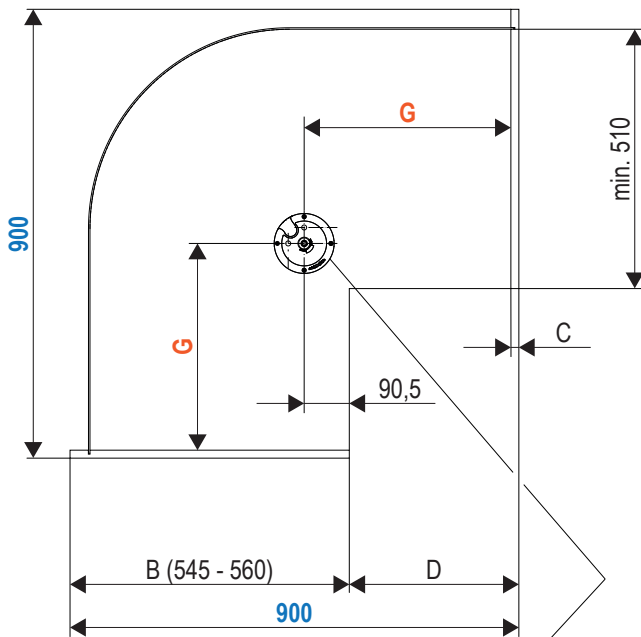

Frontenberechnung front calculation

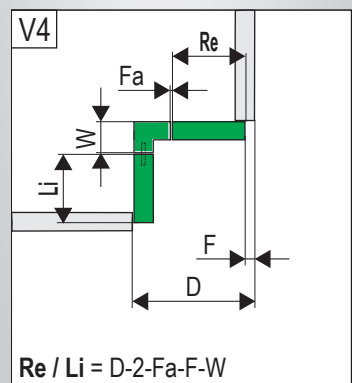
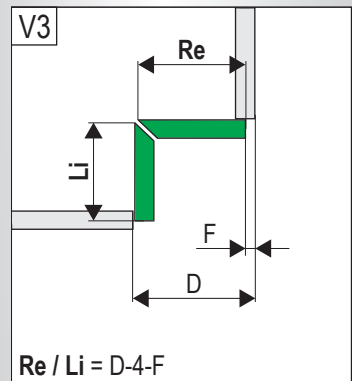
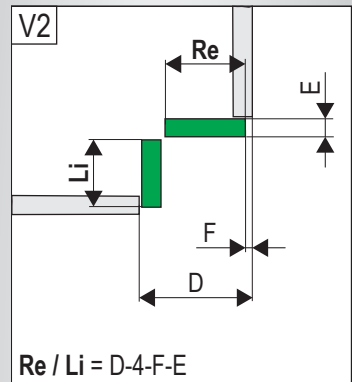
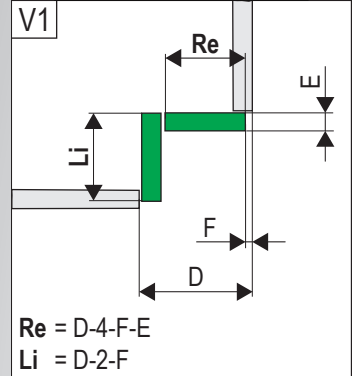

2b 800

$$G = 800 - B - C + 140,5$$

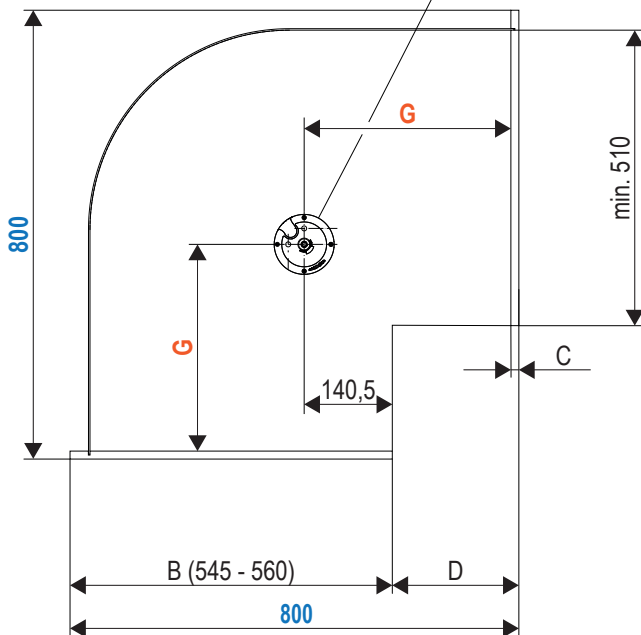

REVO 90°



3



1x



PZ2

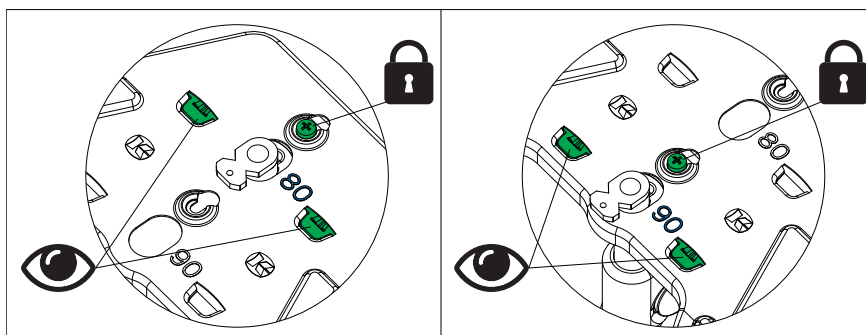
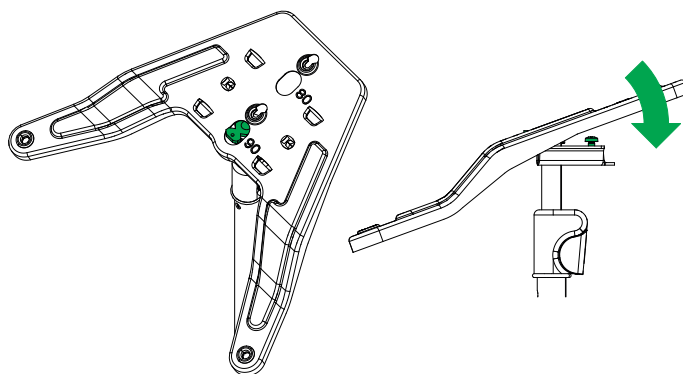
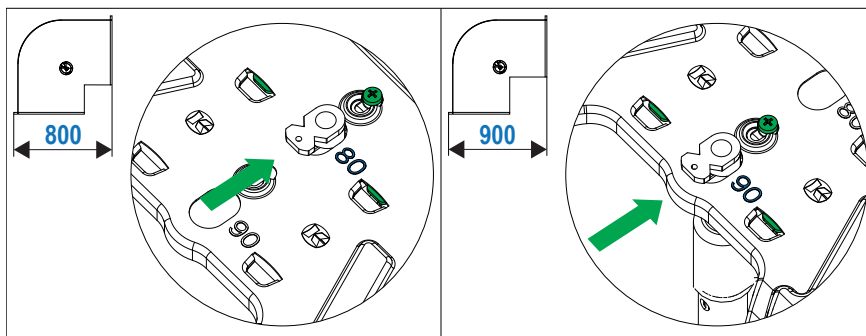
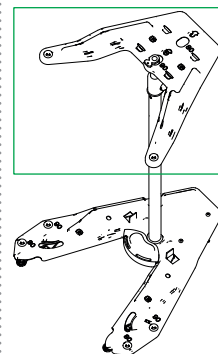
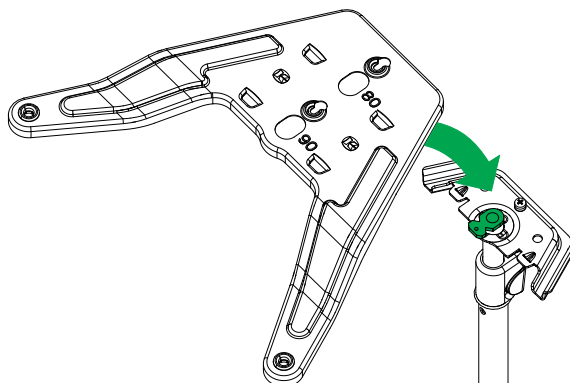

REVO 90°



4

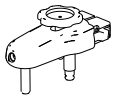

2x

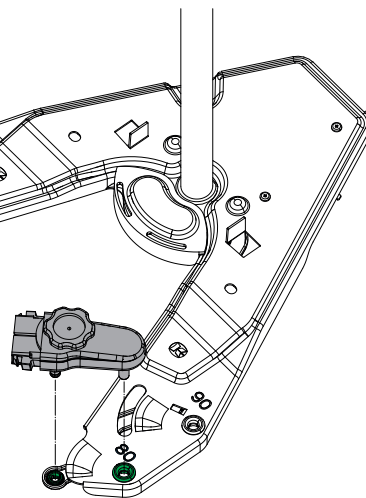
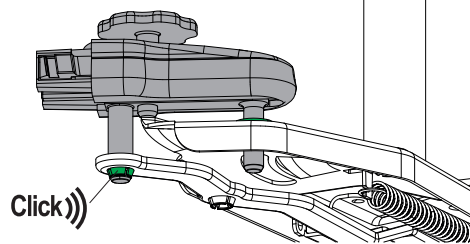
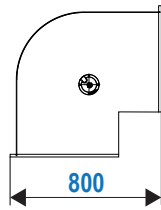
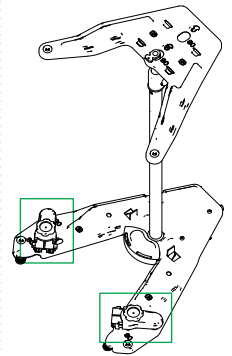
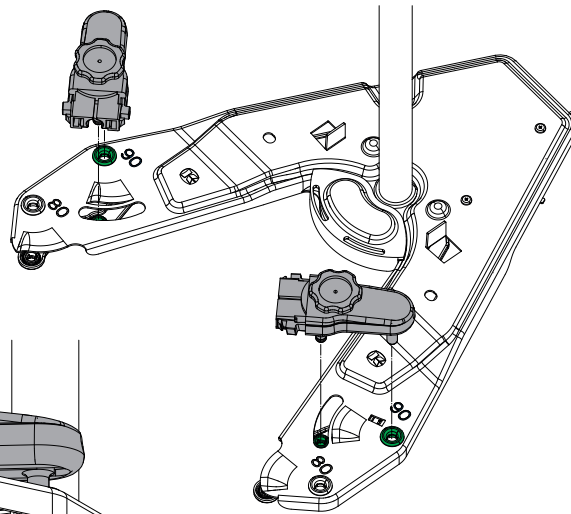
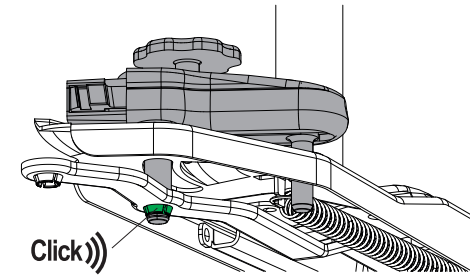
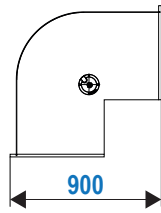

REVO 90°



5

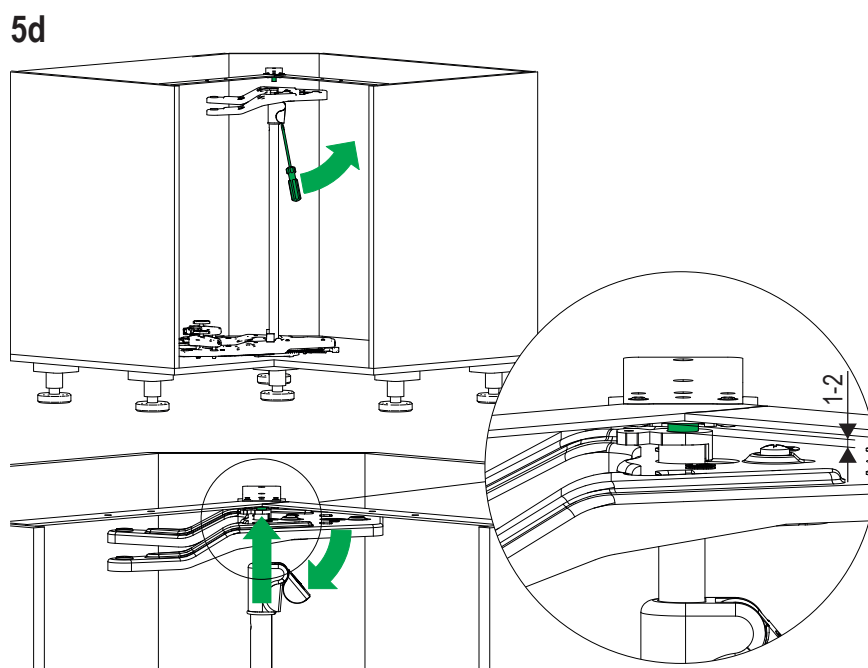
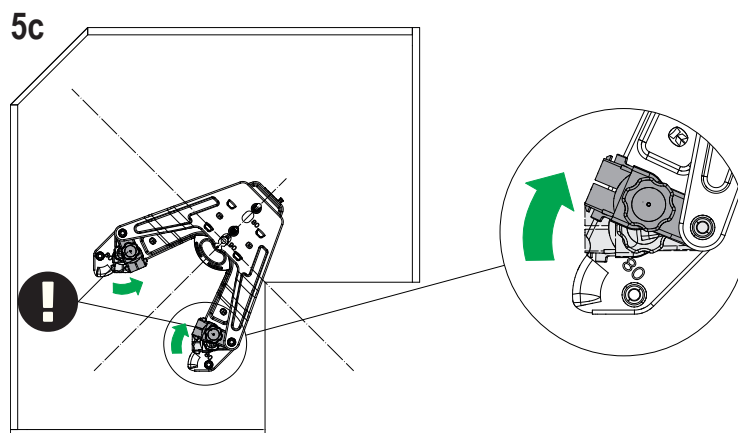
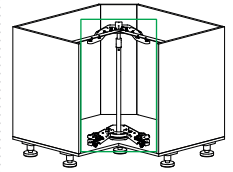
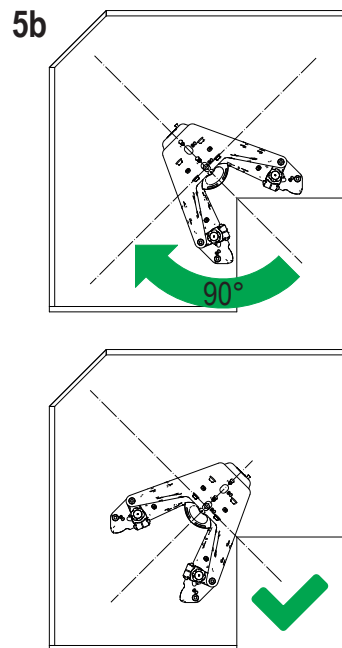
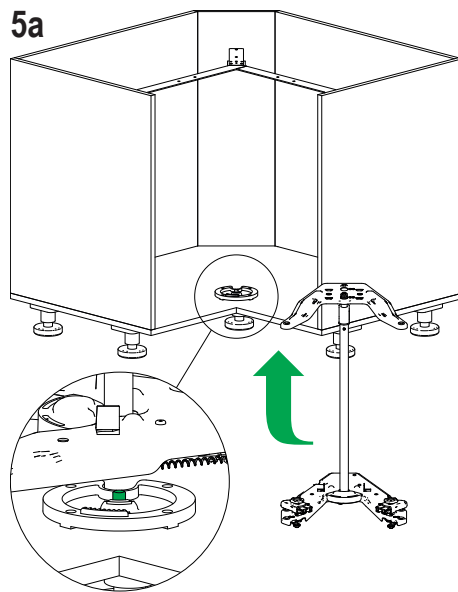
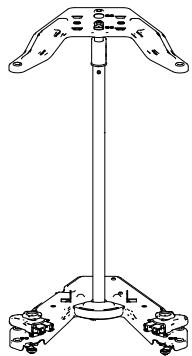

REVO 90°



6

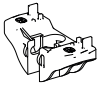

1x



1x

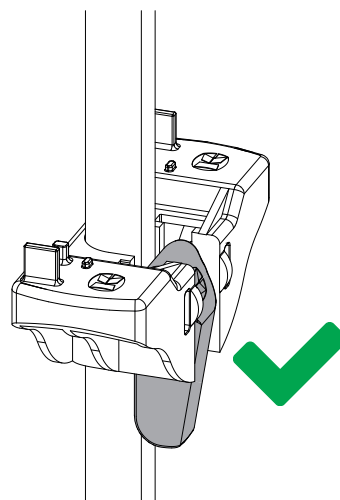
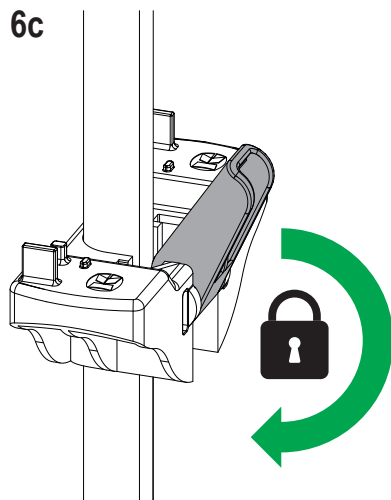
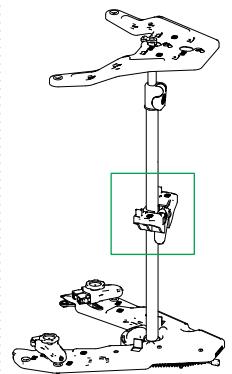
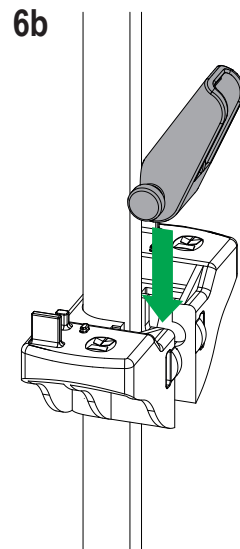
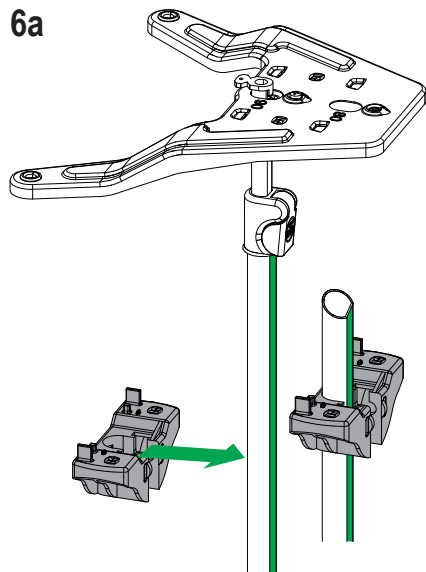

REVO 90°



7a

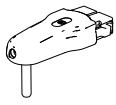

2x

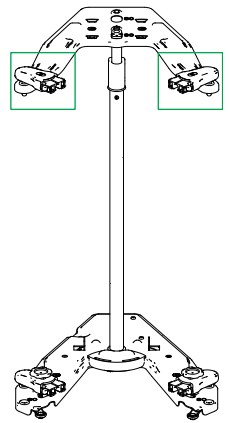
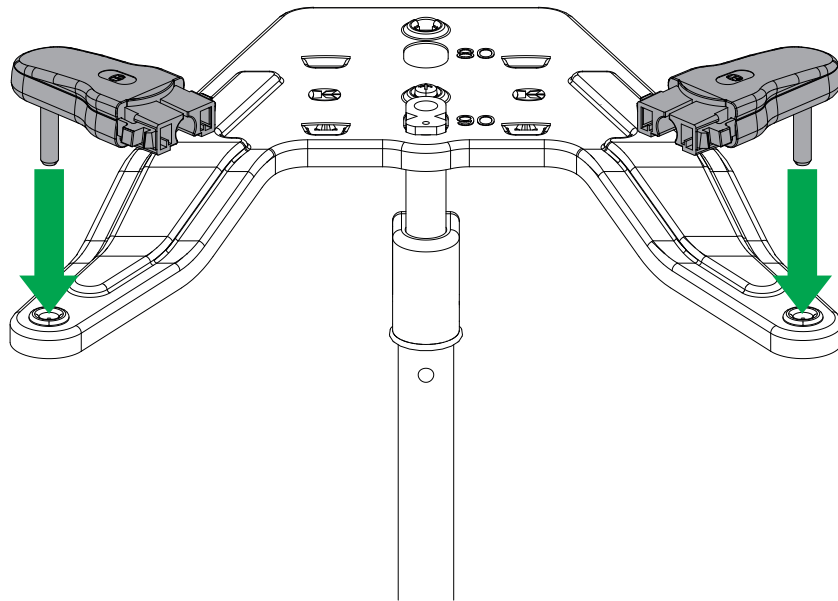
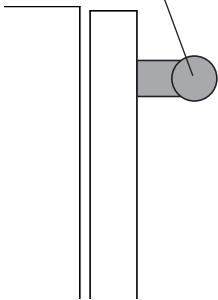

7b

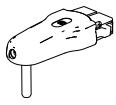

2x

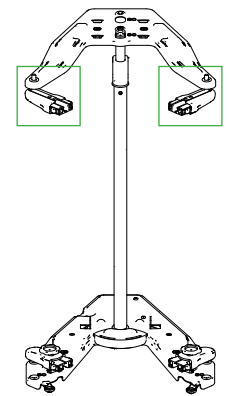
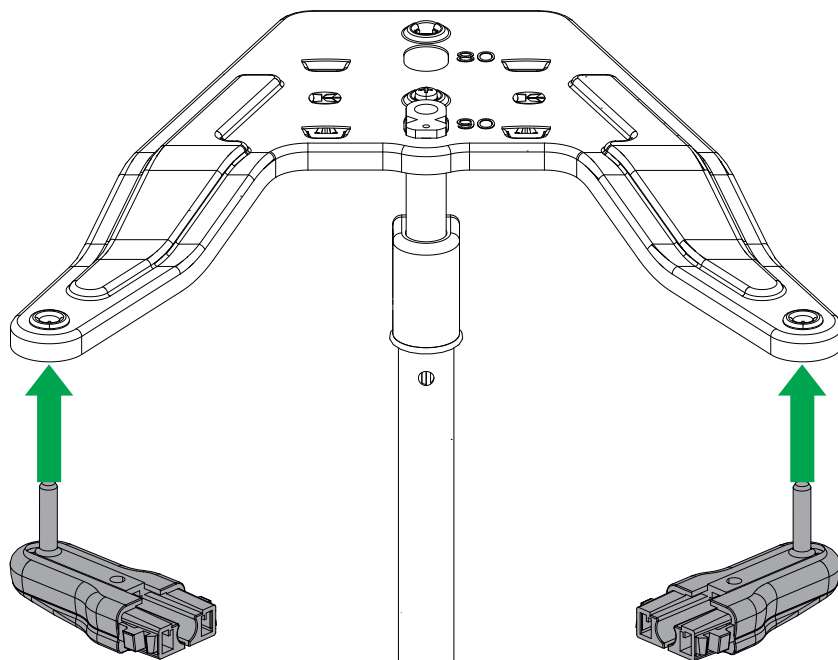
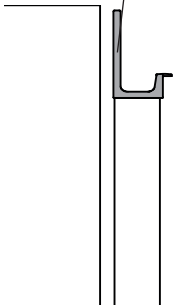

REVO 90°



8a

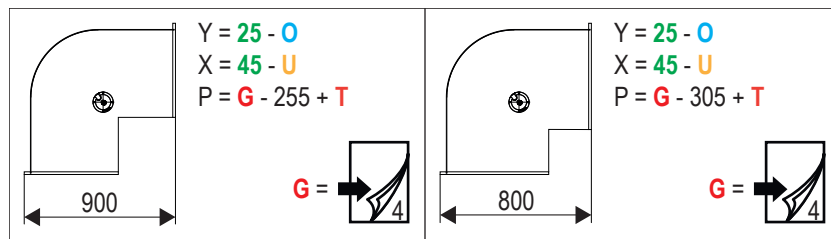
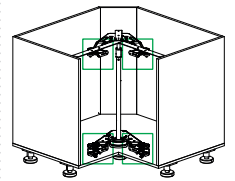
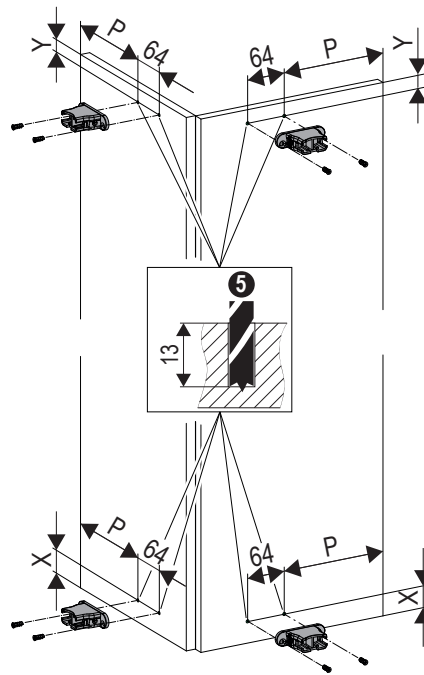
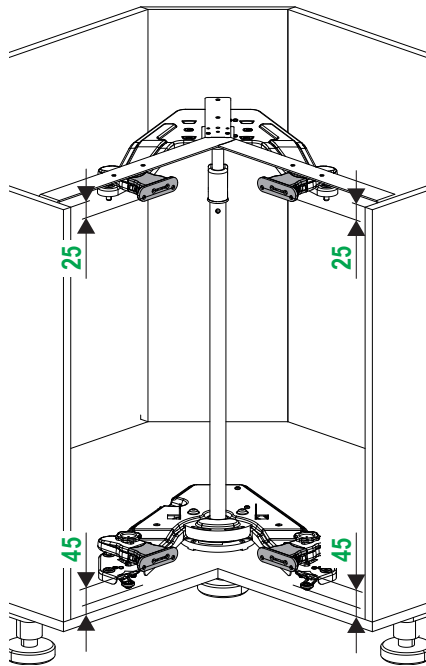
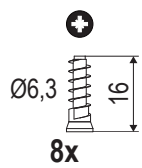
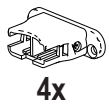
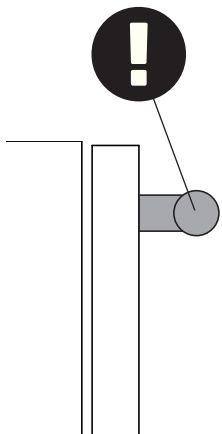
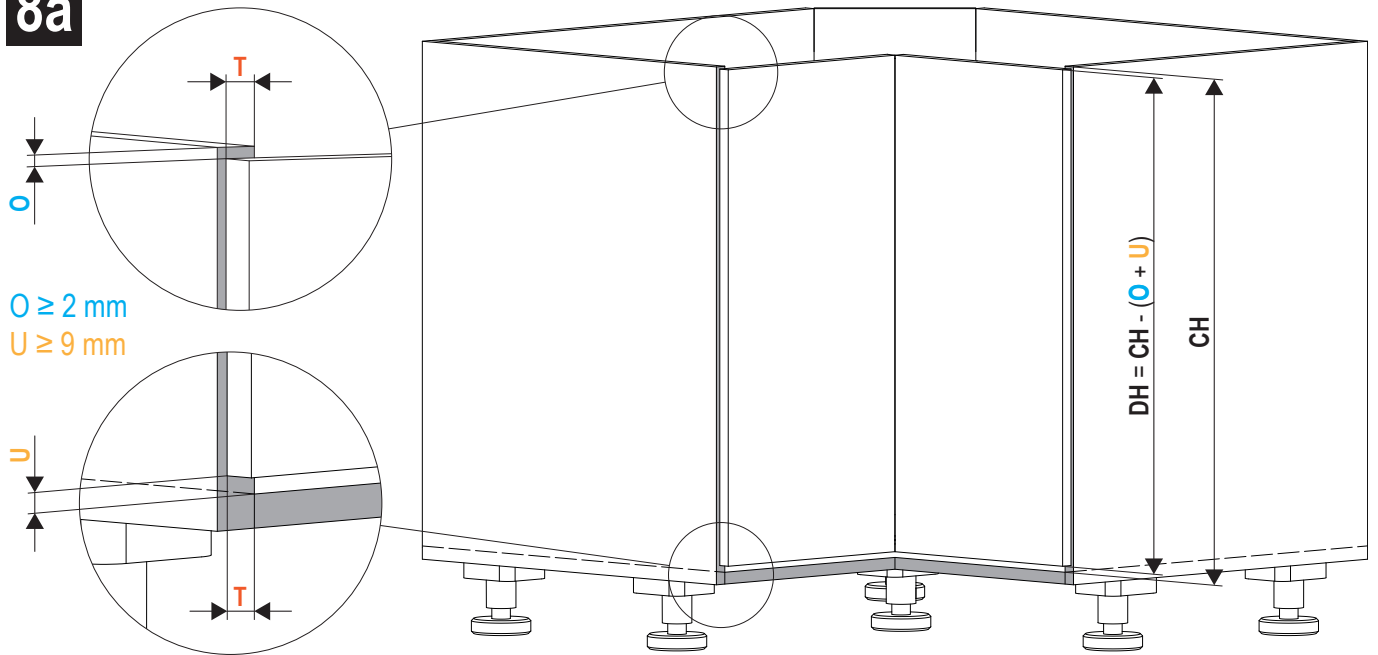

REVO 90°



8b

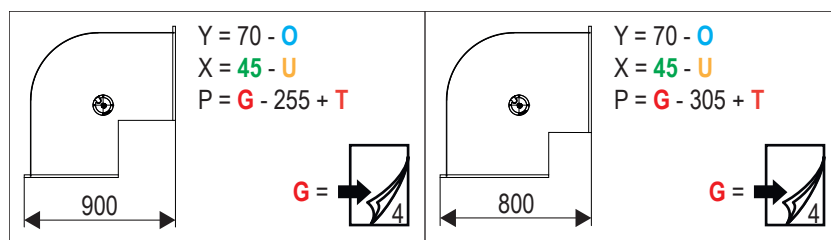
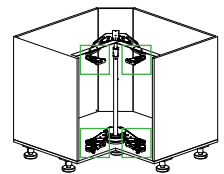
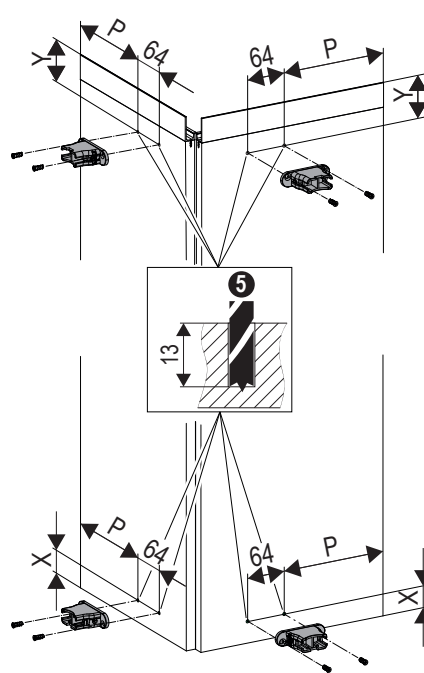
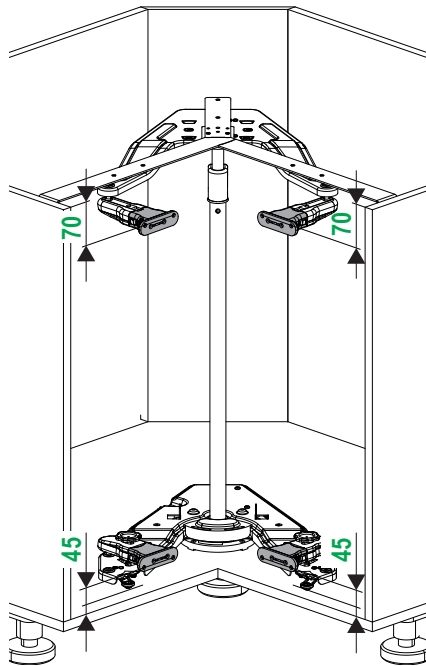
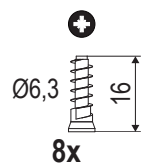
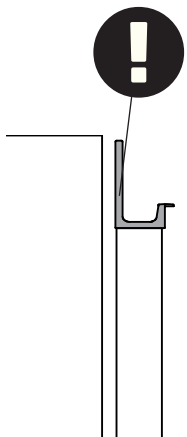
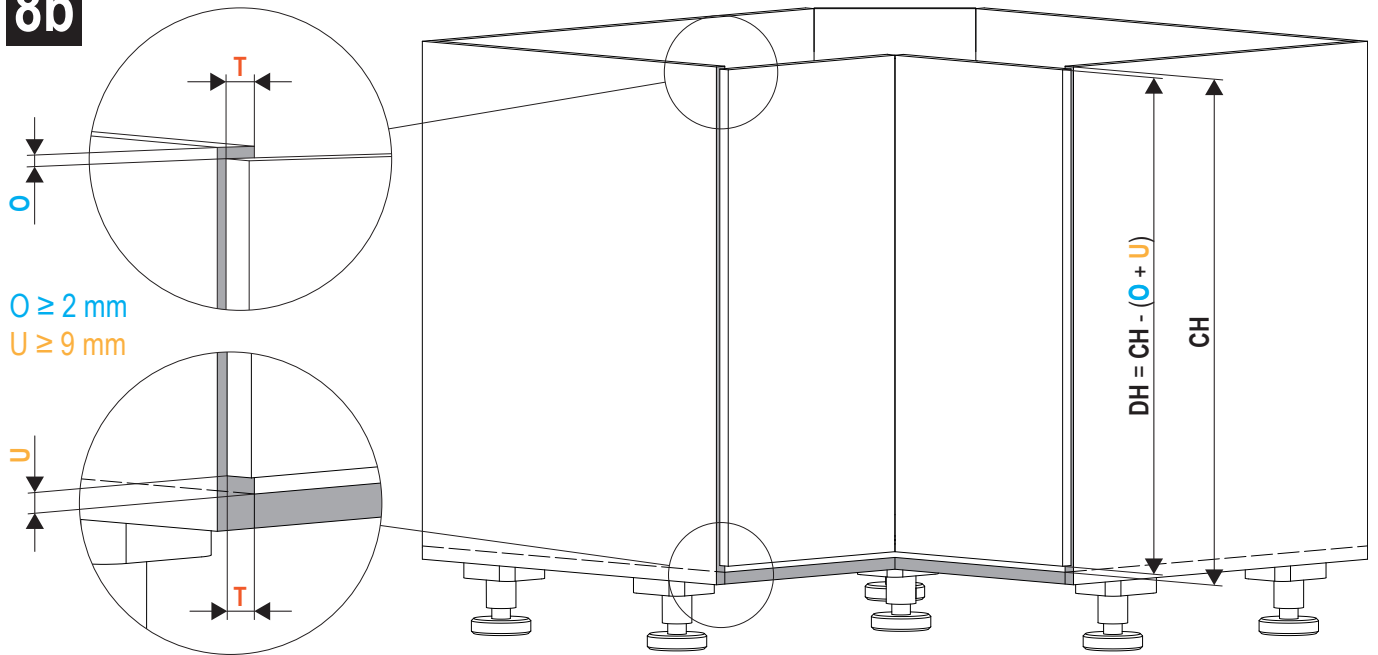

REVO 90°



9

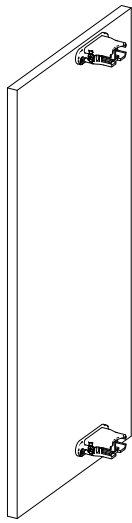

2x

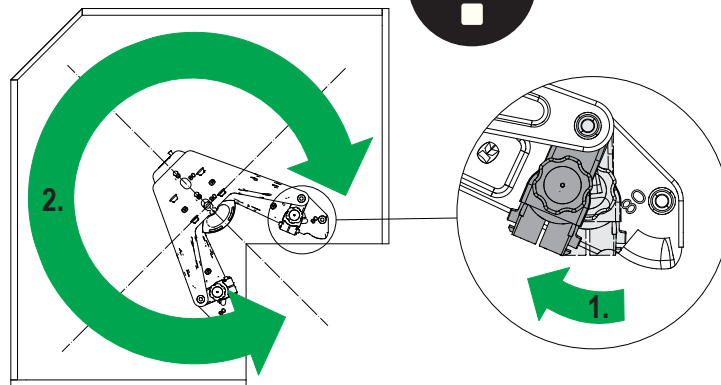
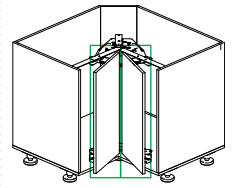
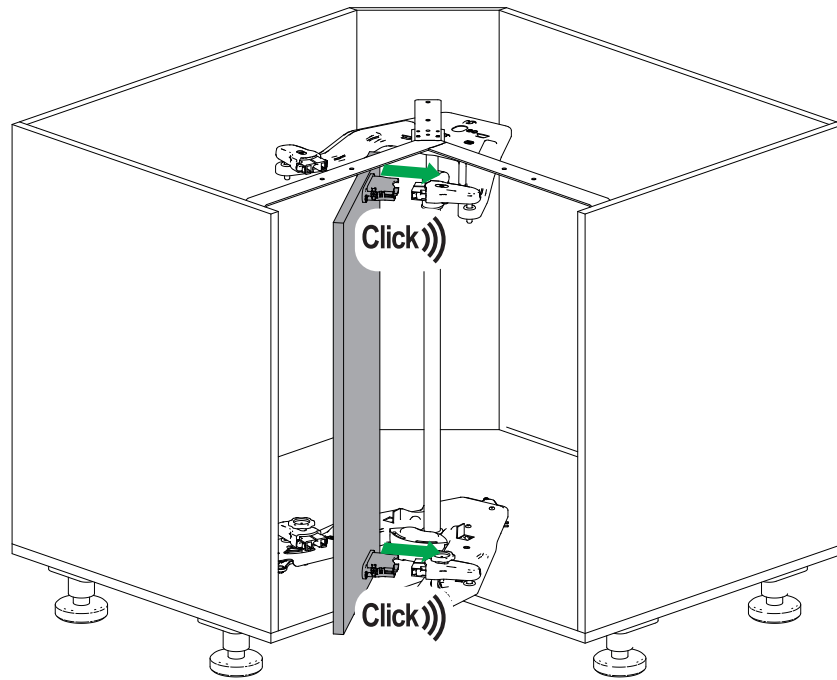

REVO 90°



10

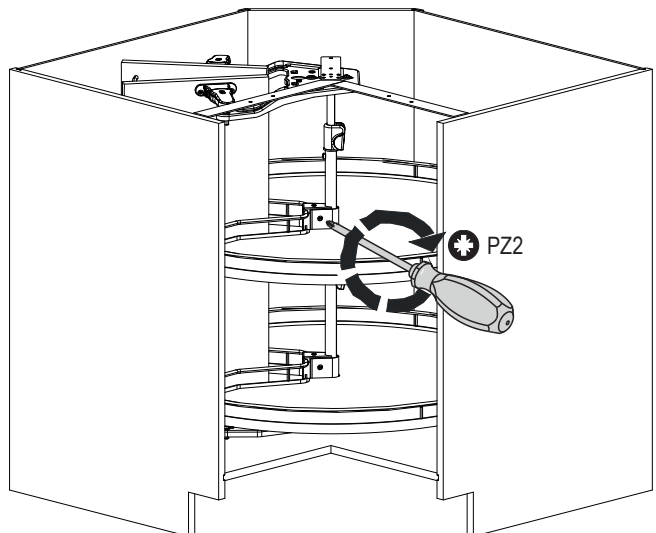
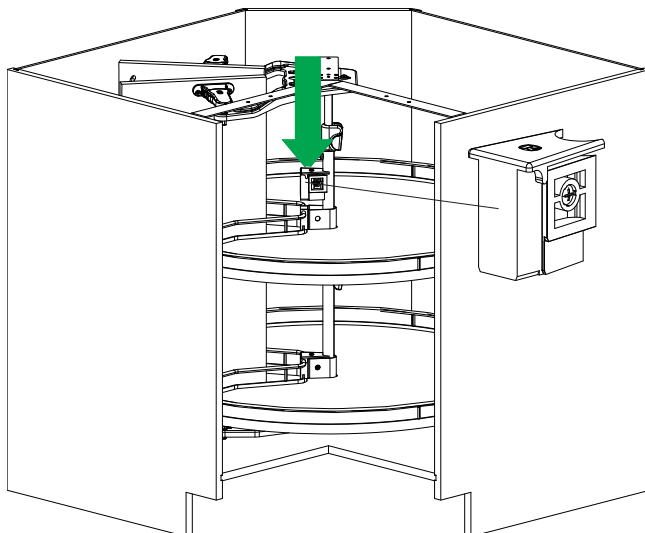
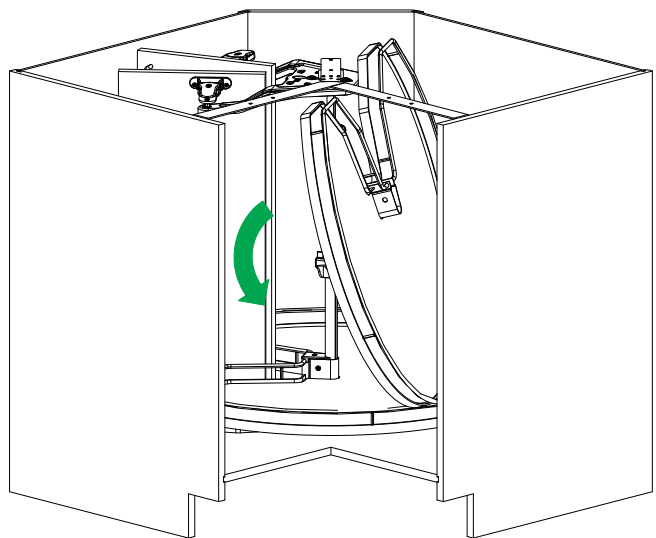
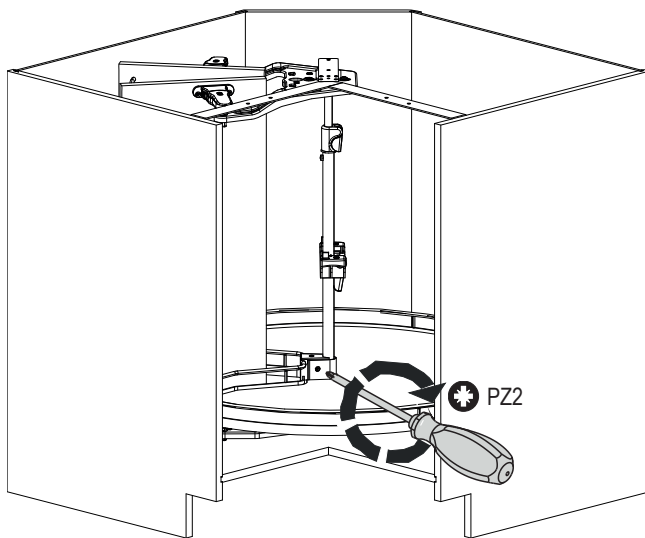
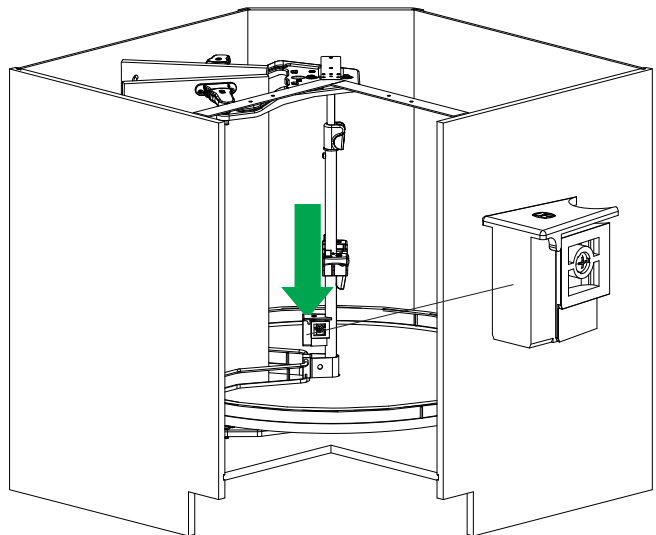
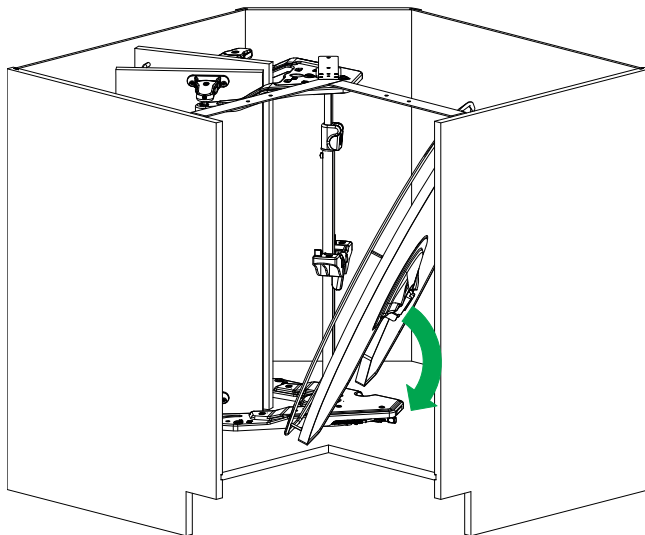
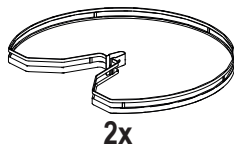

REVO 90°



11

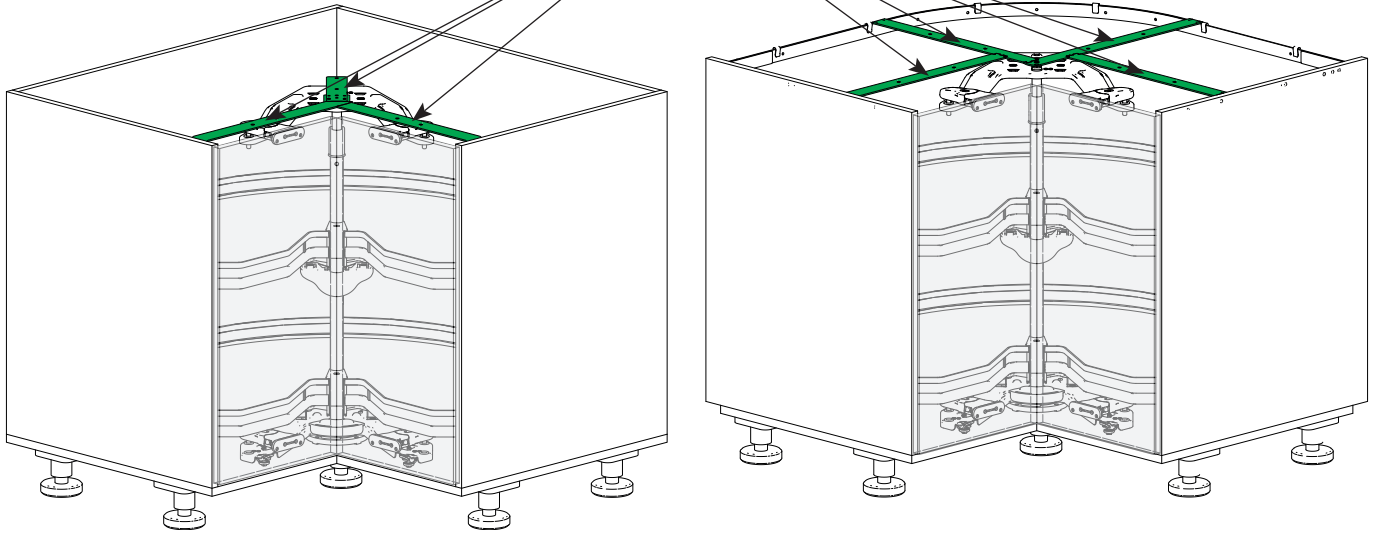

12



PZ2

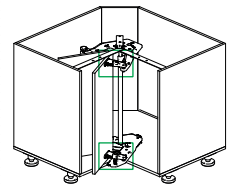
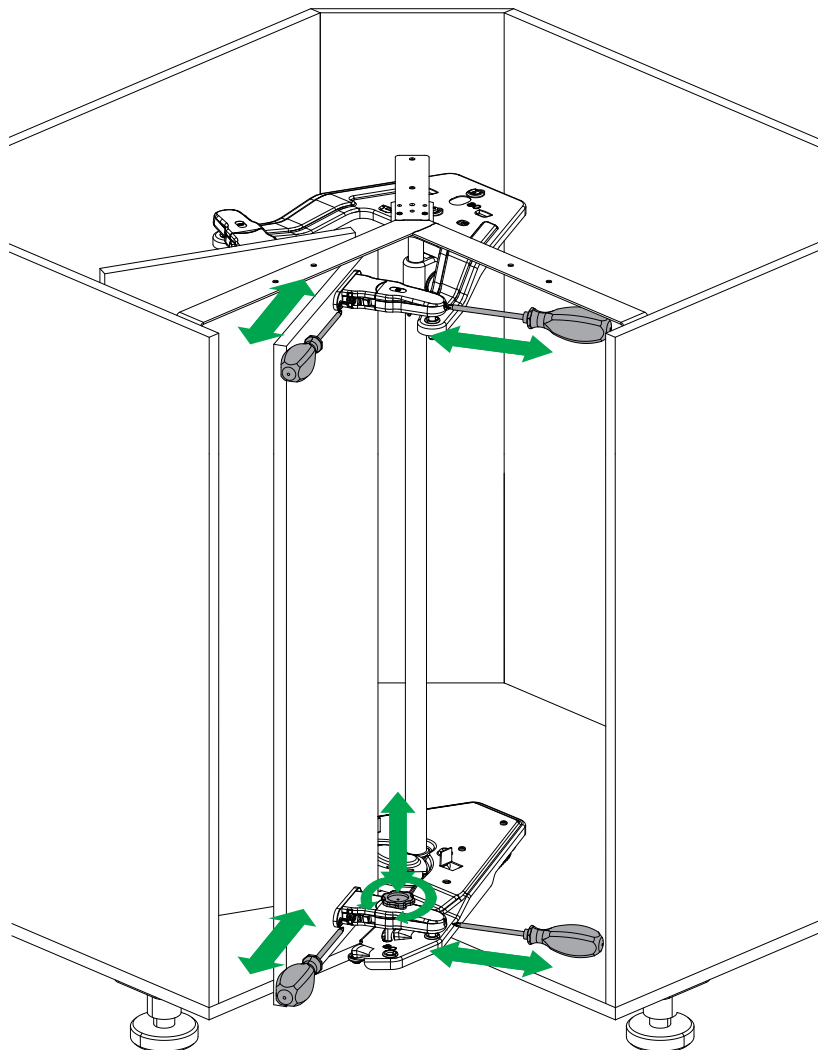



13

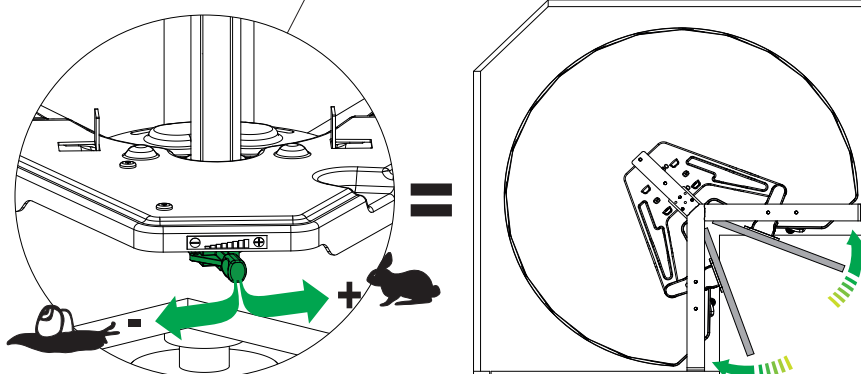
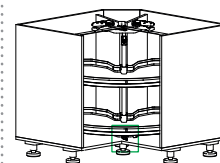
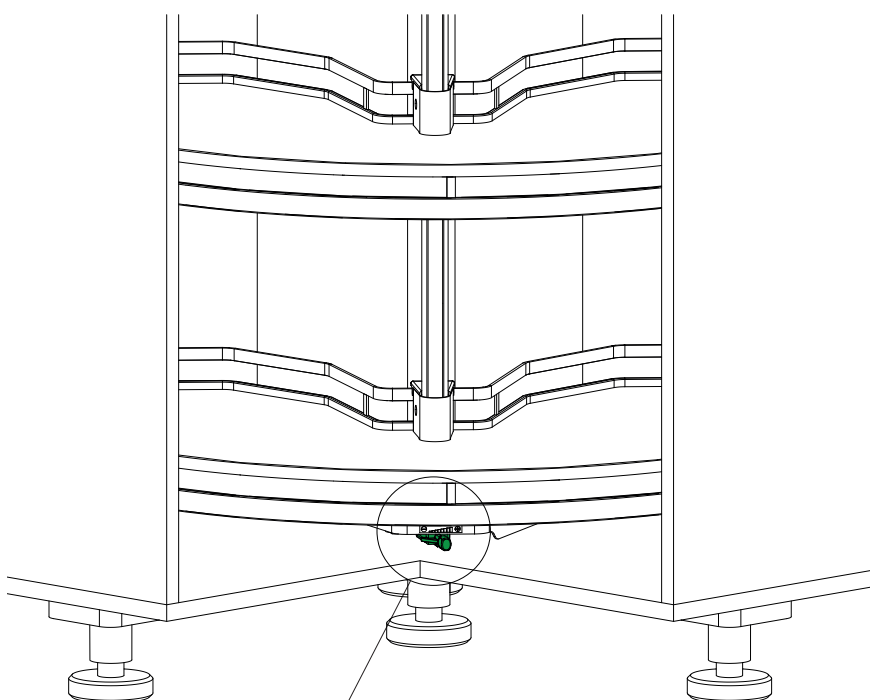



14

