

DESK

ISTRUZIONI DI MONTAGGIO ASSEMBLY INSTRUCTIONS

MODELLO:
MODEL:

411/78.0005.02

CONTENUTO DELLA CONFEZIONE INCLUDED IN THE PACKAGING

- COPPIA SISTEMA RIBALTA - PAIR OF TILTING SYSTEM

SACCHETTO ACCESSORI - ACCESSORIES

- A. Chiave esa. n.4 - n.4 Allen key
- B. Bussola M6 12x8 mm - M6 12x8 mm bush (x 8)
- C. Vite TPS M6x16 - M6x16 FHCS screw (x 8)
- D. Vite TPS M6x60 - M6x60 FHCS screw (x 10)

DIMENSIONI GENERALI GENERAL SIZES

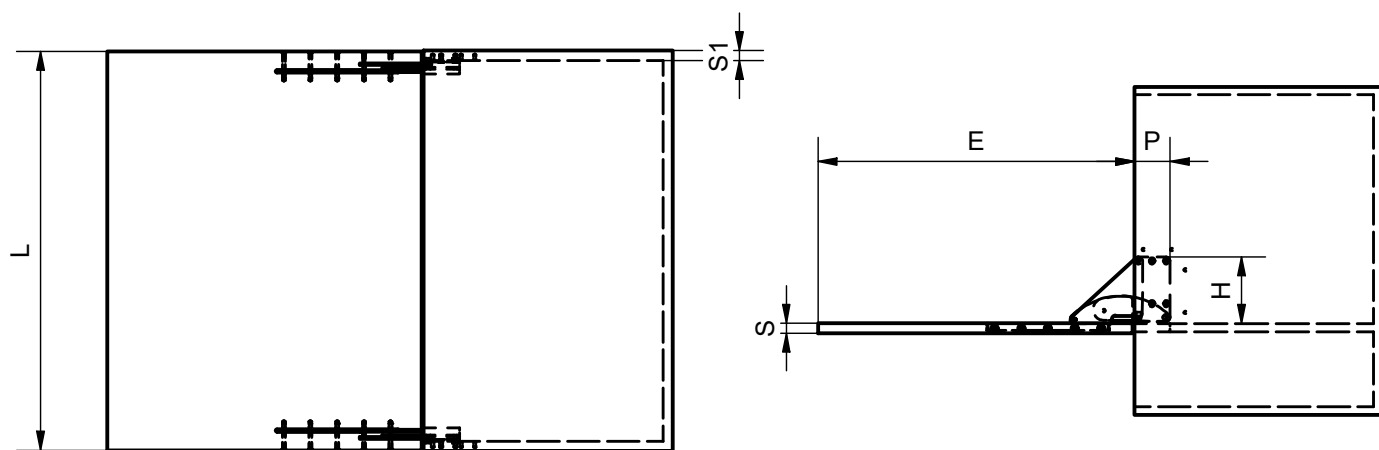

DIMENSIONE - DIMENSION	SIMBOLO - SYMBOL	mm
ALTEZZA - HEIGHT	H	MIN: 200
PROFONDITA' - DEPTH	P	MIN: 150
LARGHEZZA - WIDTH	L	MIN/MAX: 450/1200
SPESSORI PIANO - TOP THICKNESS	S	MIN/MAX: 18/22
SPESSORI SPALLE - SIDE THICKNESS	S1	MIN/MAX: 15/20
APERTURA PIANO - TOP OPENING	E	MIN/MAX: 350/800

POSIZIONE FORI - HOLES POSITION

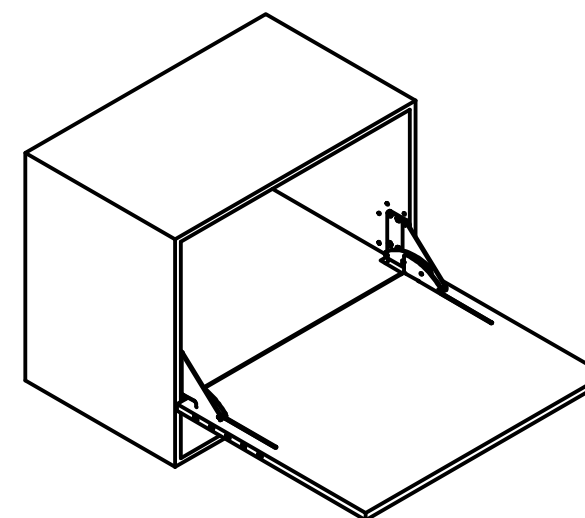
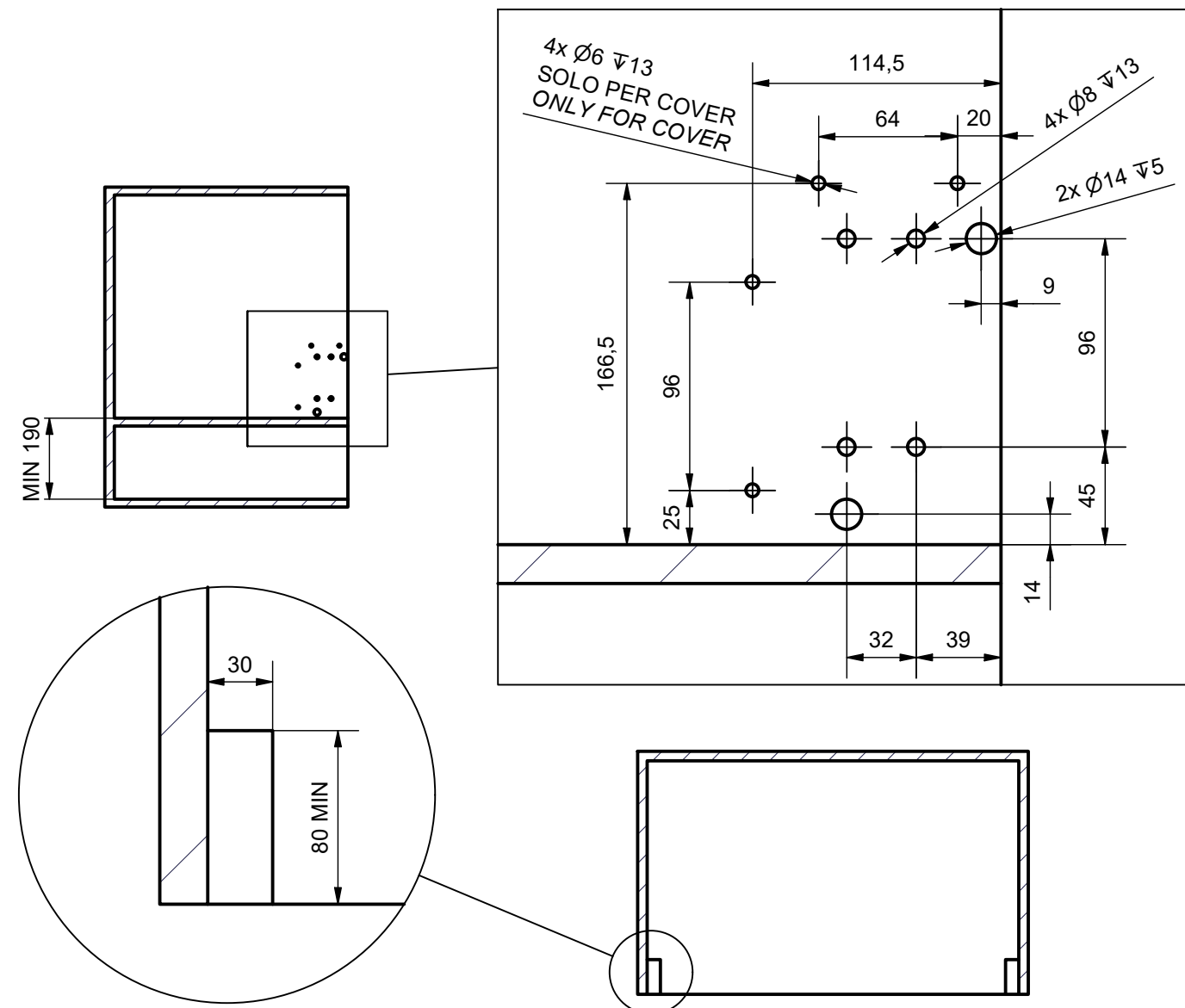

POSIZIONE FORI - HOLES POSITION

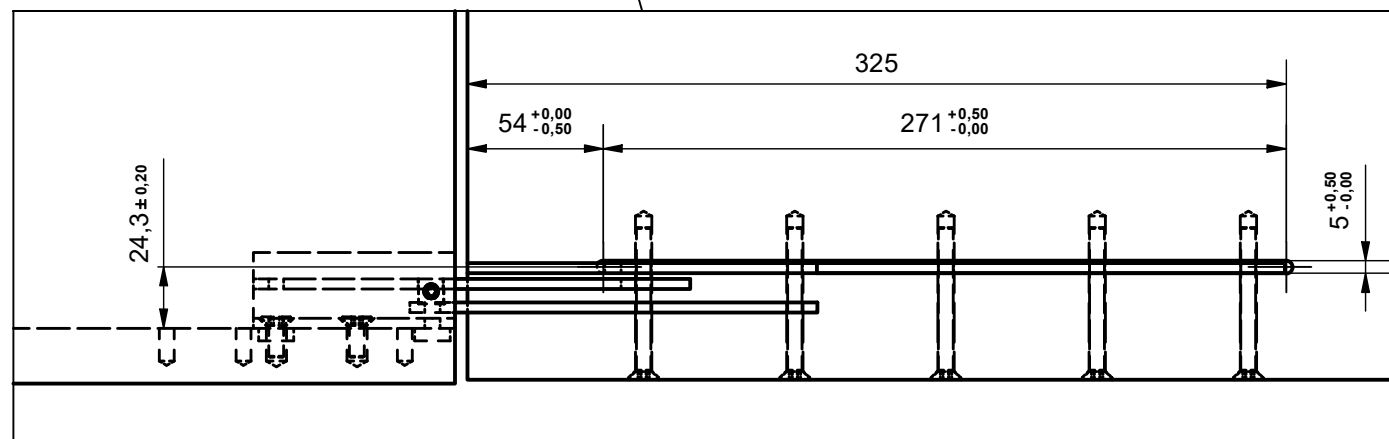
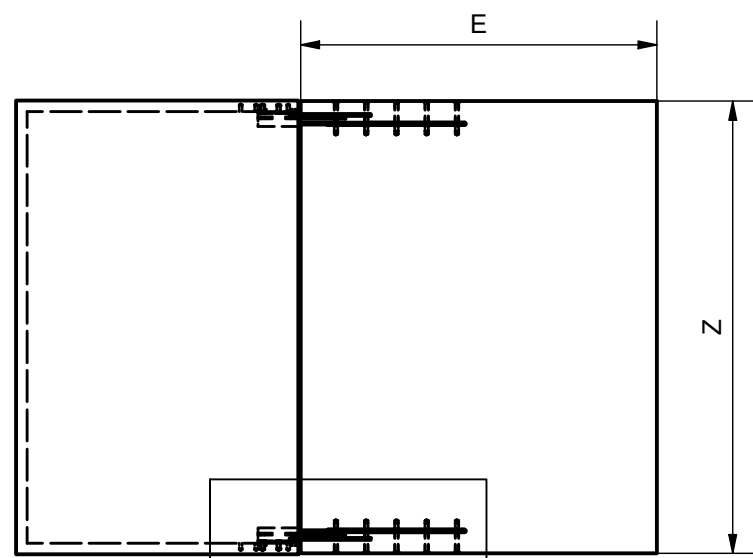
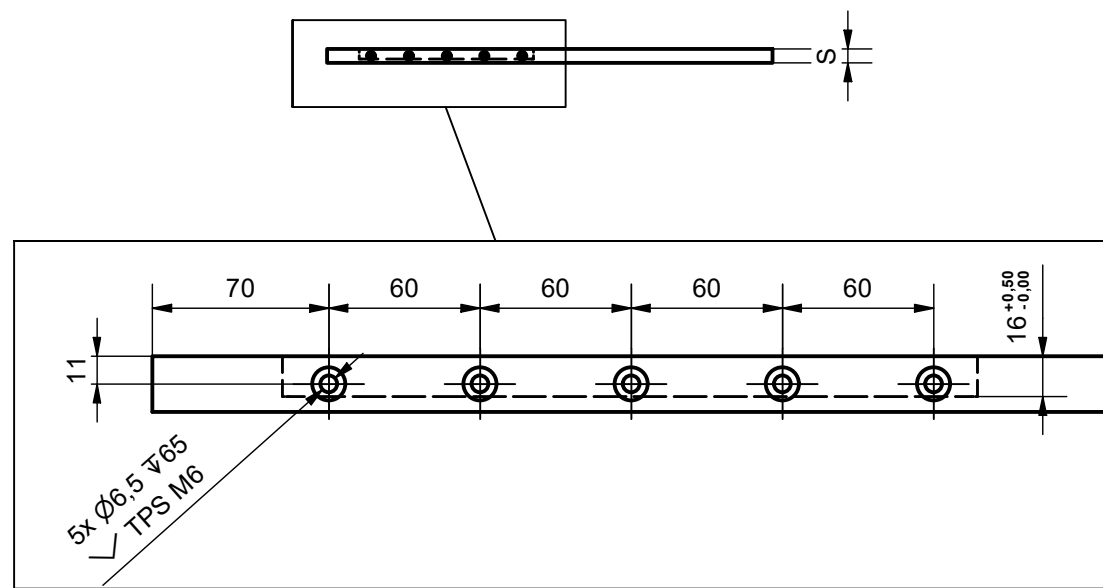

MONTAGGIO DEL MECCANISMO MOUNTING OF THE MECHANISM

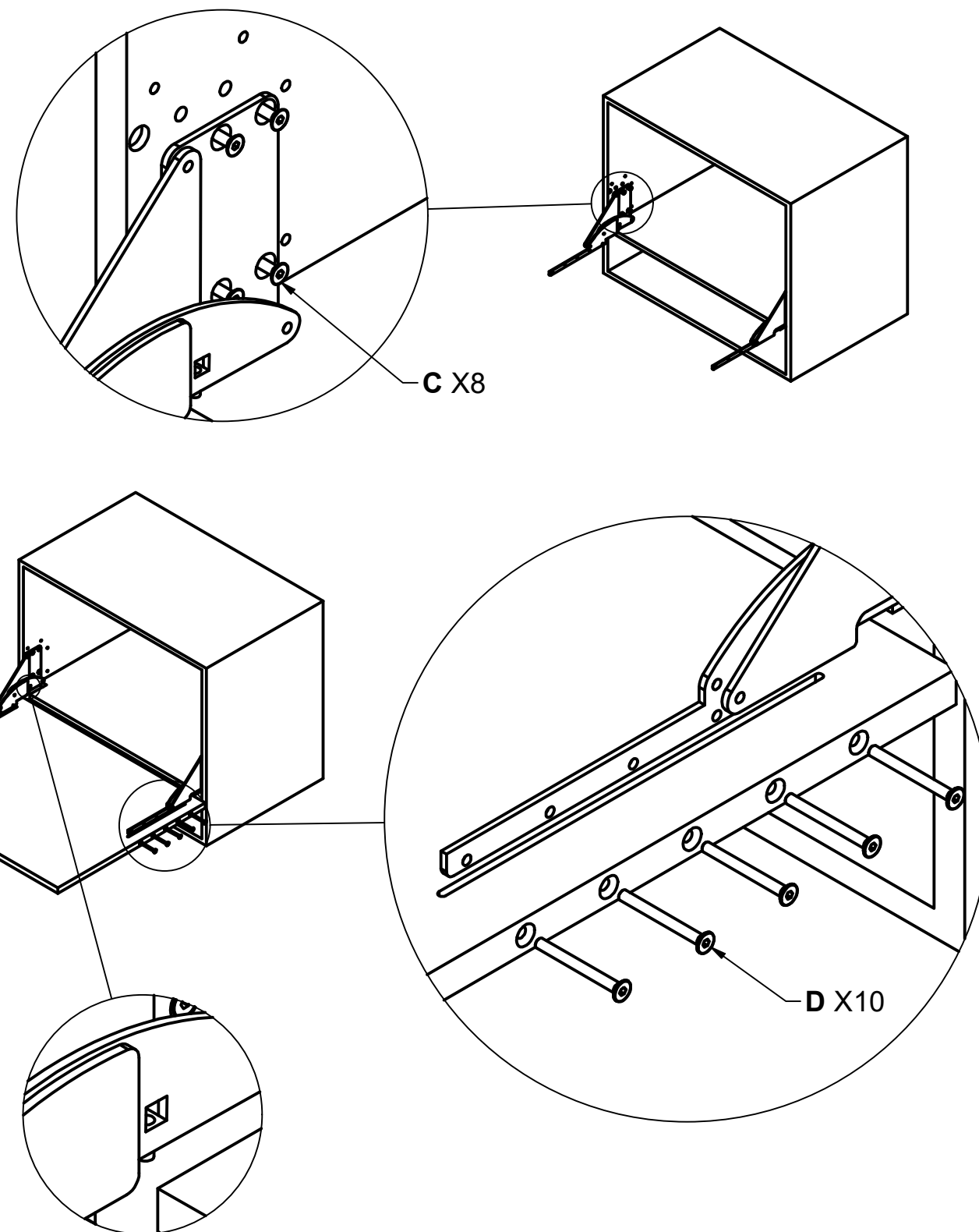

PER LA REGOLAZIONE DEL PIANO AVVITARE/SVITARE GRANO CON CHIAVE N°3 (NON INCLUSA) (UN GRANO SU OGNI LATO)
TO ADJUST THE SCREW/UNSCREW GRANO PLAN WITH KEY N°3 (NOT INCLUDED) (ONE GRANO ON EACH SIDE)