

1

2

3

4

A

A

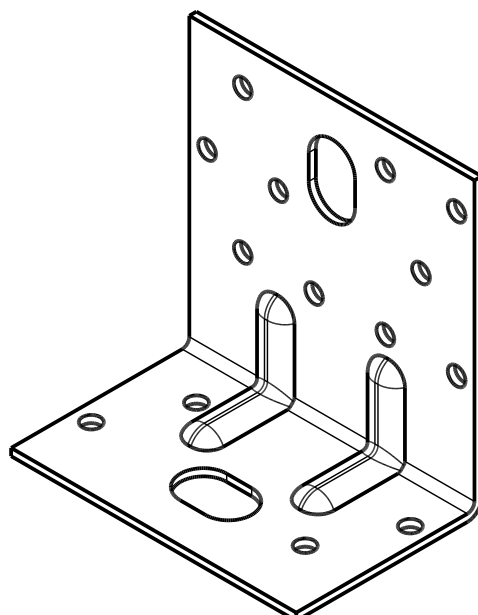
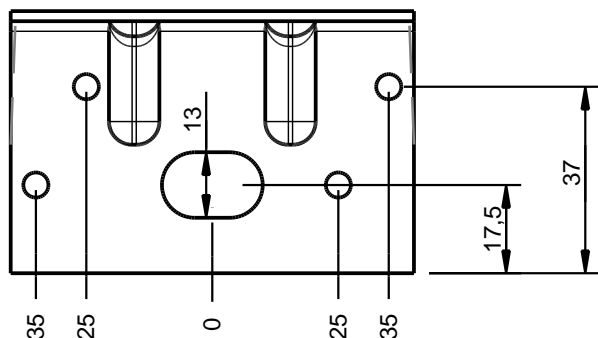

B

B

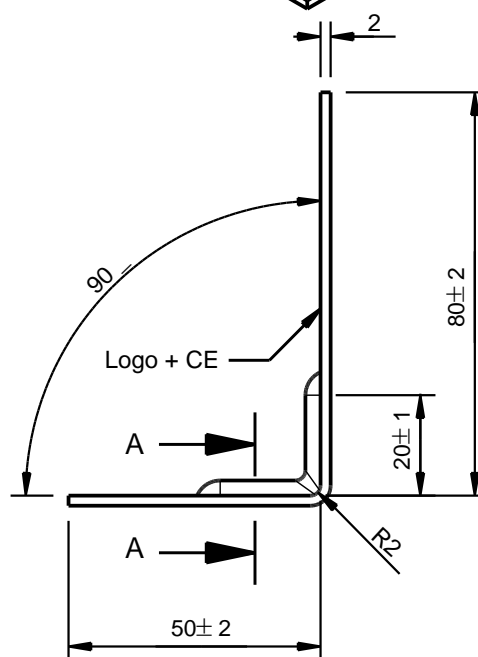
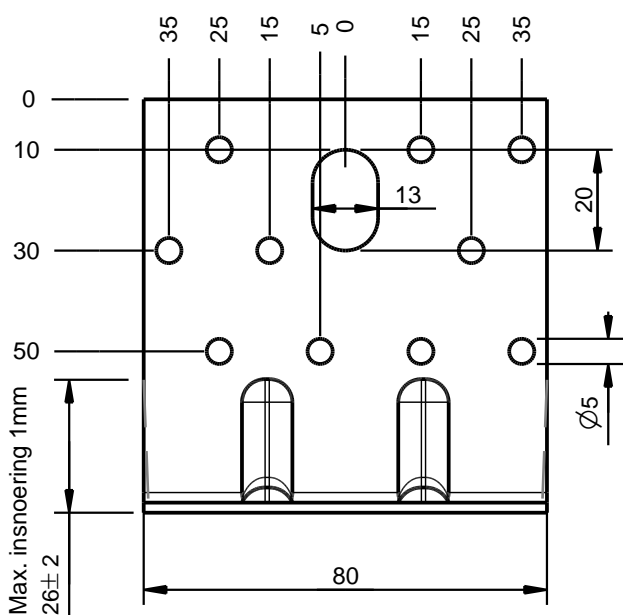

C

C

D

D

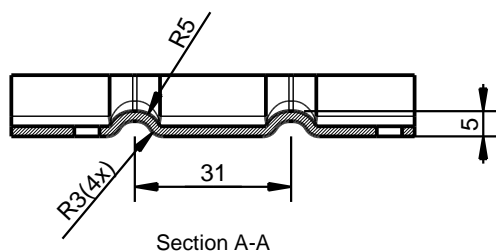

Section A-A



Produkt merken met logo 1 (Waelbers), of
Produkt merken met logo 1001 (Wurth), zie W-1616

Oppervlakte behandeling volgens
werkinstructie W-1614

Uitvoering:	artikel nr.
Sendzimier	490024
Verzinkt geel	
Verzinkt blauw	

E

E

B	Wijz ivm CE	8-11-2016	GHo	Poedercoat
A	Vervallen tekening P0607	19-9-2014	HJ	RVS
Wijziging	Omschrijving	Datum	Naam	FV

Behandeling:	Z 275	Maattoleranties: Lin.: ±0,2 Hoek: ± 2°	Datum:	19-9-2014	Eenheid mm
--------------	-------	--	--------	-----------	---------------

Materiaal soort:	M30565 130x2	breedte: +0/-0.2 dikte: +0/-0.15	Aantal:	1x
------------------	--------------	----------------------------------	---------	----

Materiaalkwaliteit:	DX51D (1.0226)	Benaming:	Hoekanker met 2 rillen (type 1) 80x50x80	schaal	1:1.5
---------------------	----------------	-----------	--	--------	-------

F

F

Tekenaar:	HJ	Gecontr.:	GHo
-----------	----	-----------	-----



Metaalindustrie Waelbers B.V.
Hoge Akkers 13
7961 AR Ruinerwold
tel: 0522-441808
fax: 0522-441845
www.waelbers.com

Tekeningnummer:

49002

© All rights reserved.
This drawing is property of Waelbers
and may not be copied or multiplied neither wholly nor partly.
It may not be submitted for persual to third parties either.



1

4