



STILE

ATTUATORE ELETTRICO A CATENA – FORZA 300 N – CORSA 400 mm
ELECTRIC CHAIN ACTUATOR – FORCE 300 N – STROKE 400 mm
BOITIER A CHAINE ELECTRIQUE – FORCE 300N – COURSE 400 mm



SPORGERE
TOP HINGED WINDOW
CHÂSSIS PROJETANT

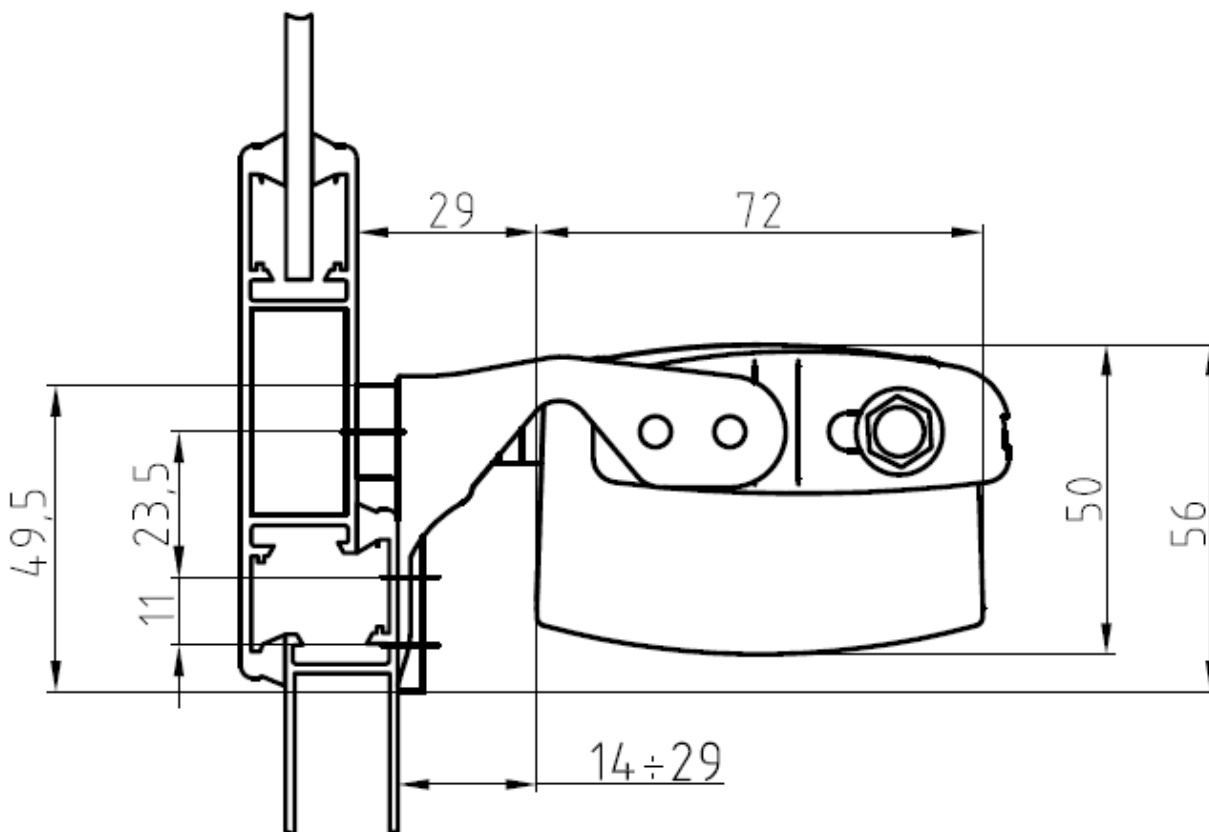

- I** Applicazione su telaio con staffa in dotazione
- GB** On the frame with pivoting brackets included
- F** Sur dormant avec étrier pivotant inclus



STILE

ATTUATORE ELETTRICO A CATENA – FORZA 300 N – CORSA 400 mm
ELECTRIC CHAIN ACTUATOR – FORCE 300 N – STROKE 400 mm
BOITIER A CHAINE ELECTRIQUE – FORCE 300N – COURSE 400 mm

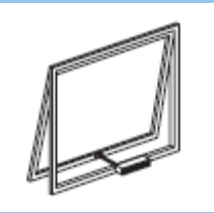

SPORGERE
TOP HINGED WINDOW
CHÂSSIS PROJETANT

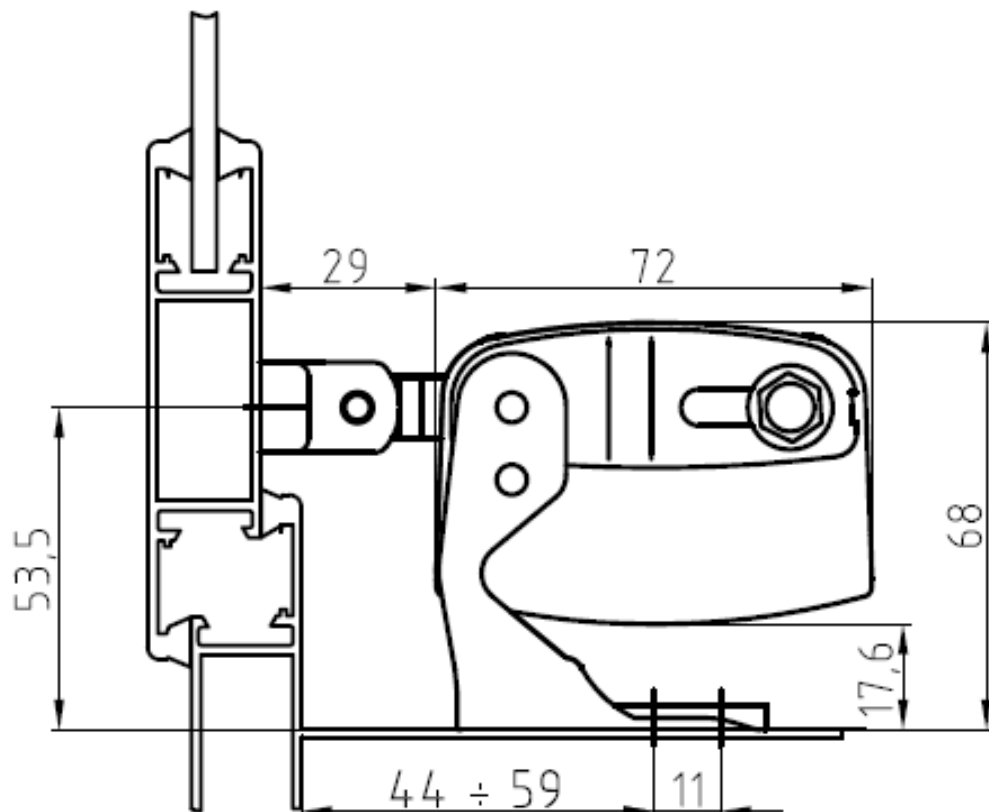

- I** Applicazione su davanzale con staffa in dotazione
- GB** On the windowsill with pivoting brackets included
- F** Sur appui avec étrier pivotant inclus



STILE

ATTUATORE ELETTRICO A CATENA – FORZA 300 N – CORSA 400 mm
ELECTRIC CHAIN ACTUATOR – FORCE 300 N – STROKE 400 mm
BOITIER A CHAINE ELECTRIQUE – FORCE 300N – COURSE 400 mm



SPORGERE CON ANTA NASCOSTA
TOP HINGED WINDOW WITH
CONCEALED VENT
CHÂSSIS PROJETANT AVEC
L'OUVRANT COUVERT PAR LE
DORMANT

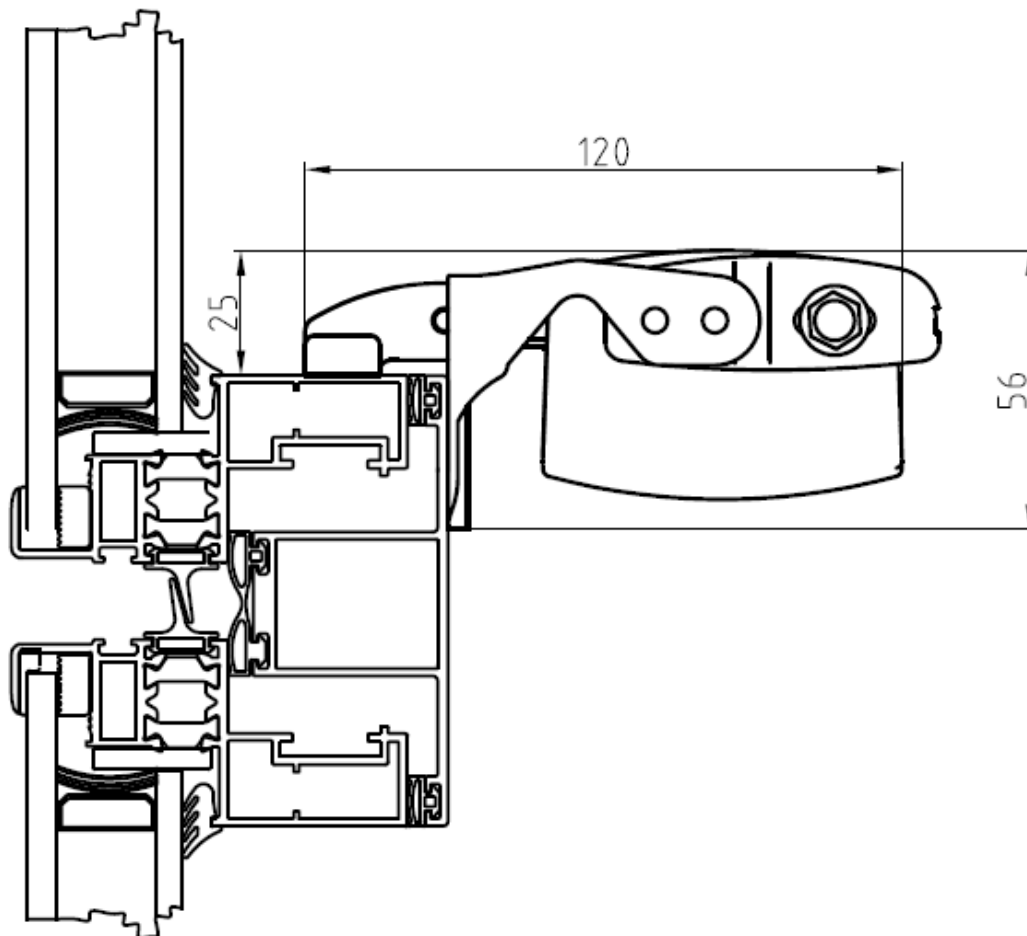

I Applicazione su telaio con staffa in dotazione e connettore per anta nascosta

GB On the frame with pivoting brackets included and chain connector for concealed vent

F Sur dormant avec étrier pivotant inclus et connecteur pour châssis avec l'ouvrant couvert par le dormant



STILE

ATTUATORE ELETTRICO A CATENA – FORZA 300 N – CORSA 400 mm

ELECTRIC CHAIN ACTUATOR – FORCE 300 N – STROKE 400 mm

BOITIER A CHAINE ELECTRIQUE – FORCE 300N – COURSE 400 mm

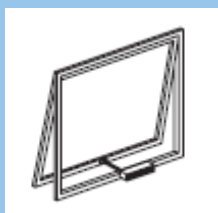

SPORGERE CON ANTA NASCOSTA

TOP HINGED WINDOW WITH
CONCEALED VENT

CHÂSSIS PROJETANT AVEC
L'OUVRANT COUVERT PAR LE
DORMANT

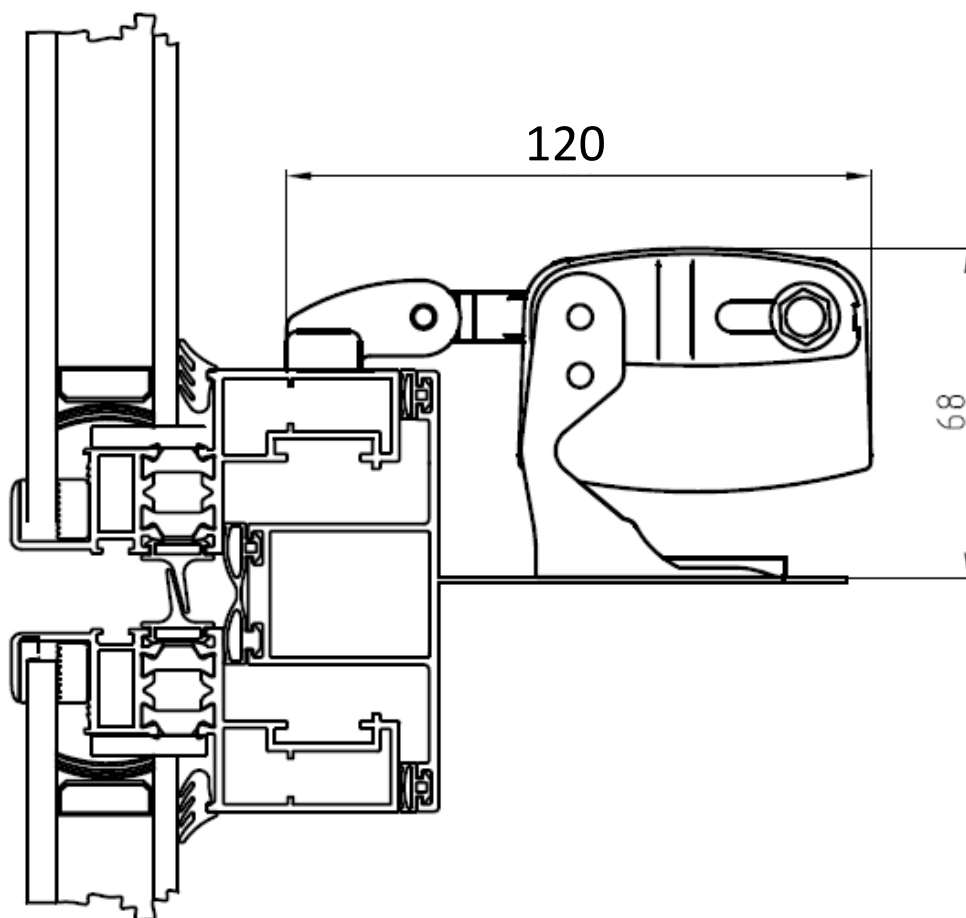

I Applicazione su davanzale con staffa in dotazione e connettore per anta nascosta

GB On the windowsill with pivoting brackets included and chain connector for concealed vent

F Sur appui avec étrier pivotant inclus et connecteur pour chassis avec l'ouvrant couvert par le dormant



STILE

ATTUATORE ELETTRICO A CATENA – FORZA 300 N – CORSA 400 mm
ELECTRIC CHAIN ACTUATOR – FORCE 300 N – STROKE 400 mm
BOITIER A CHAÎNE ELECTRIQUE – FORCE 300N – COURSE 400 mm

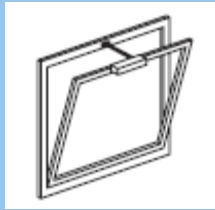

VASISTAS
BOTTOM HINGED WINDOWS
CHÂSSIS SOUFFLET

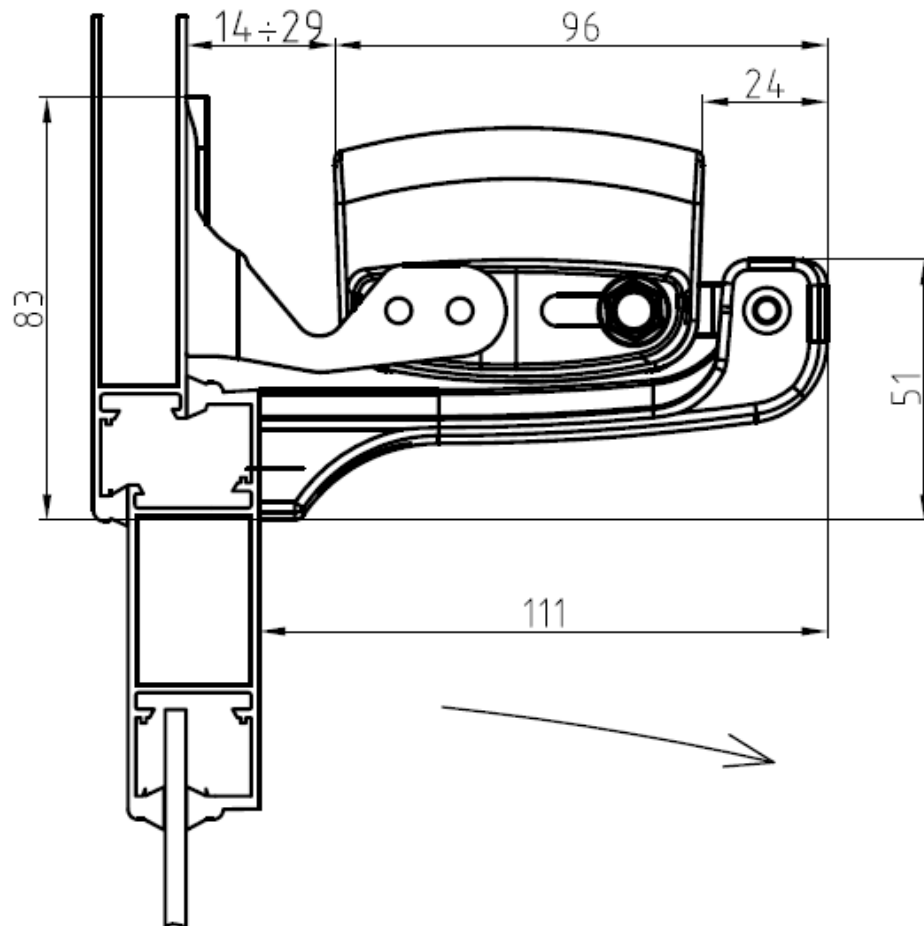

I Applicazione su anta con staffe indotazione

GB On the vent with pivoting brackets included

F Sur volet avec étrier pivotant inclus



STILE

ATTUATORE ELETTRICO A CATENA – FORZA 300 N – CORSA 400 mm
ELECTRIC CHAIN ACTUATOR – FORCE 300 N – STROKE 400 mm
BOITIER A CHAINE ELECTRIQUE – FORCE 300N – COURSE 400 mm

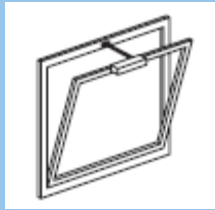

VASISTAS
BOTTOM HINGED WINDOWS
CHÂSSIS SOUFFLET

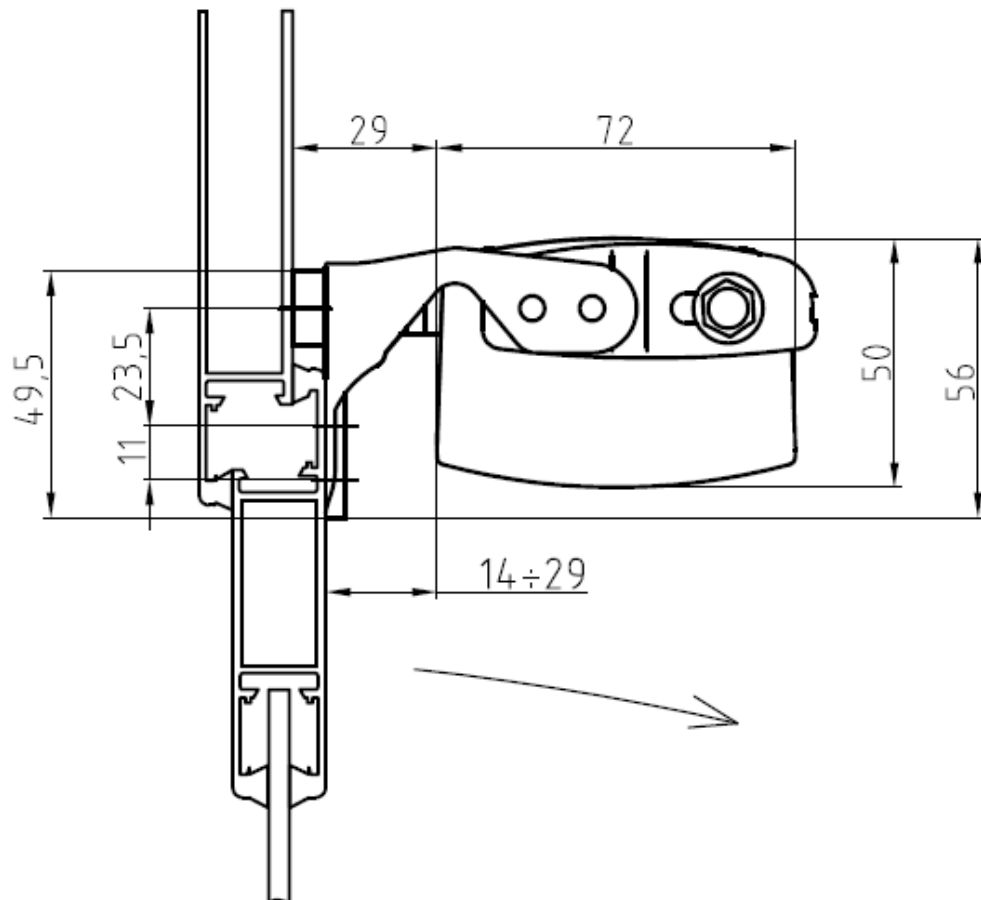

- I** Applicazione su telaio con staffe in dotazione e staffa a vasistas
- GB** On the frame with pivoting brackets included and bottom hinged bracket
- F** Sur dormant avec étrier pivotant inclus et étrier pour chassis a soufflet