

**Zubehör:**  
WireLane Clip

**Accessories:**  
WireLane Clip

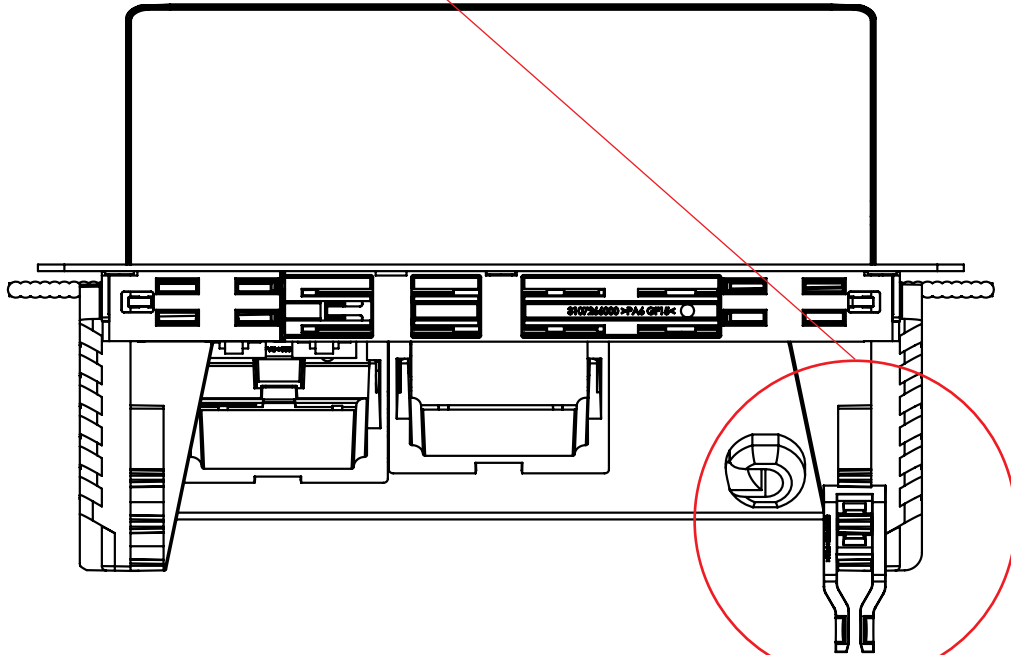

**Schulte Elektrotechnik GmbH & Co. KG**

Jüngerstraße 21  
D-58515 Lüdenscheid

Telefon +49 23 51 / 94 81-0  
Telefax +49 23 51 / 4 26 58

Email [info@schulte.com](mailto:info@schulte.com)  
Alle weiteren Produkte aus  
unserem Sortiment finden  
Sie unter:  
[www.evoline.com](http://www.evoline.com)



**EVoline FlipTop Push**



**Lieferumfang / Delivery includes:**

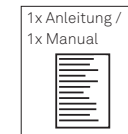
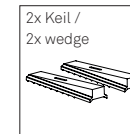
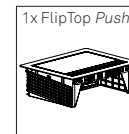

## Funktionserläuterung

Vor Gebrauch bitte beachten:  
Öffnet sich durch einfaches Antippen  
des Deckels (Soft Touch)

## Functional description

Please read instructions before use  
Opens by simply tipping the cover  
(soft touch)

## Montageanleitung / Vorbereitung

Der EVoline® FlipTop Push  
kann in Plattenstärken von  
10 bis 50 mm eingebaut werden.  
Der Lochausschnitt muss mit einem  
Mindestabstand von 100 mm zur  
Plattenkante platziert werden.

## Mounting instructions / Preparation

The EVoline® FlipTop Push can be  
mounted in desk plates from  
10 up to 50 mm thickness.  
The cut-out must have a minimum  
distance of 100 mm from the plate  
edges.

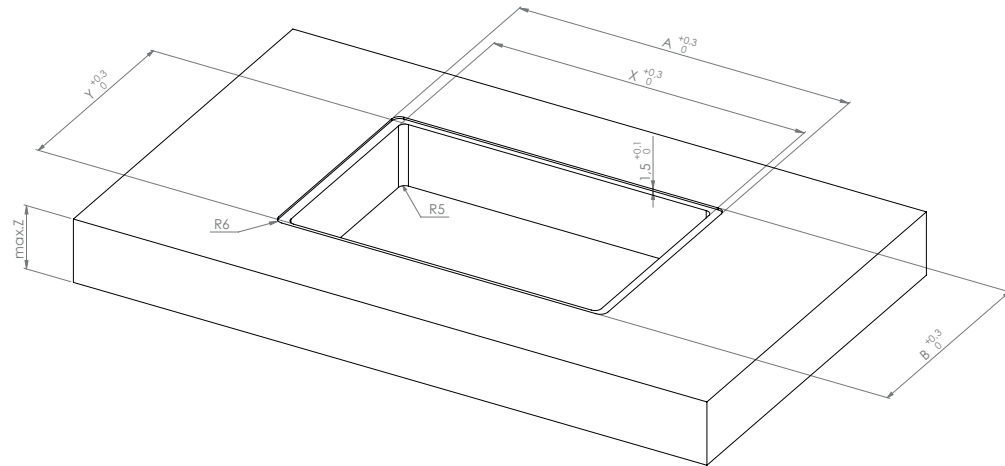

XL	360 mm	167 mm	345 mm	157 mm	max. 50 mm
L	310 mm	167 mm	295 mm	157 mm	max. 50 mm
M	260 mm	167 mm	245 mm	157 mm	max. 50 mm
S	210 mm	167 mm	195 mm	157 mm	max. 50 mm
Ausführung model	A	B	X	Y	Z
	Flächenbündiger Einbau flush installation		Normaler Einbau normal installation		

Bitte bei einer Plattenstärke  
von über 40 mm beachten!

Please note for desk plates with  
a thickness from more than 40 mm!

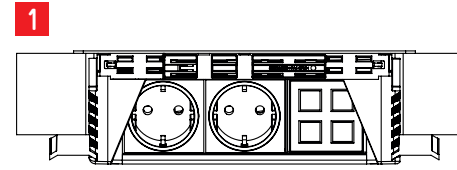
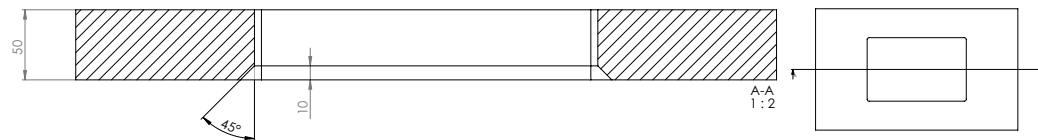

Produkt im  
Tischausschnitt  
positionieren

Place product  
in cutout

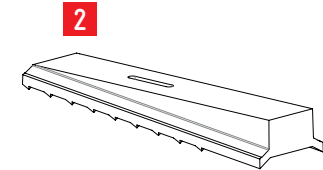

Fixierkeil

Fixing wedge

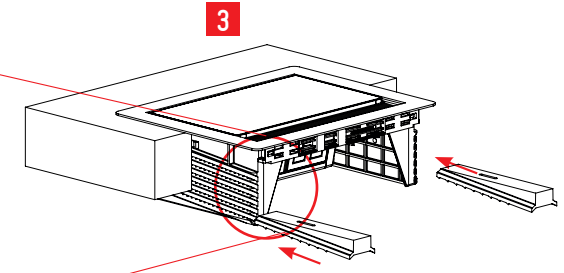
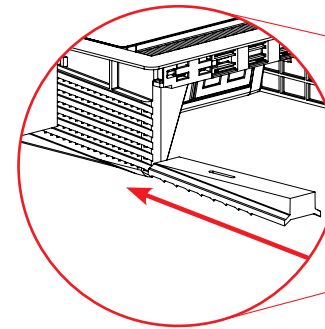

Beide Fixierkeile  
bis zum Rastpunkt  
einschieben.

Slide in both  
wedges until  
locked.

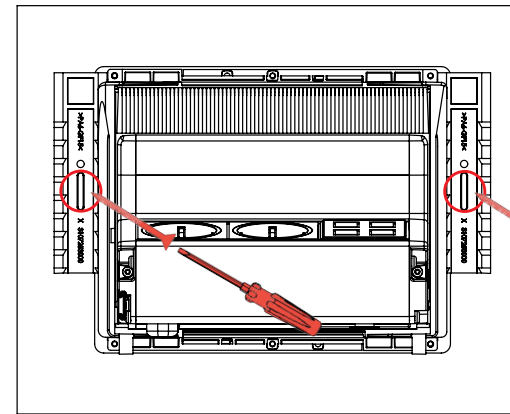

Zusätzliche  
Fixierung durch  
2 Schrauben

Additional fixing with  
2 screws

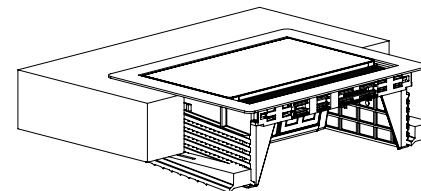

Bitte ziehen  
Sie nach  
abgeschlossener  
Montage die  
Schutzfolie ab.

After assembly  
please remove  
protective foil.

